

# *The European Union*

## EDICT OF GOVERNMENT

In order to promote public education and public safety, equal justice for all, a better informed citizenry, the rule of law, world trade and world peace, this legal document is hereby made available on a noncommercial basis, as it is the right of all humans to know and speak the laws that govern them.

EN 1994-2 (2005) (English): Eurocode 4: Design of composite steel and concrete structures - Part 2: General rules and rules for bridges [Authority: The European Union Per Regulation 305/2011, Directive 98/34/EC, Directive 2004/18/EC]



BLANK PAGE



EUROPEAN STANDARD

EN 1994-2

NORME EUROPÉENNE

EUROPÄISCHE NORM

October 2005

ICS 91.010.30; 91.080.10; 91.080.40; 93.040

Supersedes ENV 1994-2:1997  
Incorporating corrigendum July 2008

English Version

## Eurocode 4 - Design of composite steel and concrete structures - Part 2: General rules and rules for bridges

Eurocode 4 - Calcul des structures mixtes acier-béton -  
Partie 2: Règles générales et règles pour les ponts

Eurocode 4 - Bemessung und konstruktion von  
Verbundtragwerken aus Stahl und Beton - Teil 2:  
Allgemeine Bemessungsregeln und Anwendungsregeln für  
Brücken

This European Standard was approved by CEN on 7 July 2005.

CEN members are bound to comply with the CEN/CENELEC Internal Regulations which stipulate the conditions for giving this European Standard the status of a national standard without any alteration. Up-to-date lists and bibliographical references concerning such national standards may be obtained on application to the Central Secretariat or to any CEN member.

This European Standard exists in three official versions (English, French, German). A version in any other language made by translation under the responsibility of a CEN member into its own language and notified to the Central Secretariat has the same status as the official versions.

CEN members are the national standards bodies of Austria, Belgium, Cyprus, Czech Republic, Denmark, Estonia, Finland, France, Germany, Greece, Hungary, Iceland, Ireland, Italy, Latvia, Lithuania, Luxembourg, Malta, Netherlands, Norway, Poland, Portugal, Slovakia, Slovenia, Spain, Sweden, Switzerland and United Kingdom.



EUROPEAN COMMITTEE FOR STANDARDIZATION  
COMITÉ EUROPÉEN DE NORMALISATION  
EUROPÄISCHES KOMITEE FÜR NORMUNG

Management Centre: rue de Stassart, 36 B-1050 Brussels

<b>Contents</b>	<b>Page</b>
<b>Foreword</b> .....	<b>7</b>
<b>Section 1 General</b> .....	<b>11</b>
1.1 Scope.....	11
1.1.1 Scope of Eurocode 4.....	11
1.1.2 Scope of Part 1-1 of Eurocode 4.....	11
1.1.3 Scope of Part 2 of Eurocode 4.....	12
1.2 Normative references.....	12
1.2.1 General reference standards.....	12
1.2.2 Other reference standards.....	12
1.2.3 Additional general and other reference standards for composite bridges .....	13
1.3 Assumptions.....	13
1.4 Distinction between principles and application rules.....	14
1.5 Definitions.....	14
1.5.1 General.....	14
1.5.2 Additional terms and definitions used in this Standard.....	14
1.5.2.1 Composite member.....	14
1.5.2.2 Shear connection.....	14
1.5.2.3 Composite behaviour.....	14
1.5.2.4 Composite beam.....	14
1.5.2.5 Composite column.....	14
1.5.2.6 Composite slab.....	14
1.5.2.7 Composite frame.....	14
1.5.2.8 Composite joint.....	15
1.5.2.9 Propped structure or member.....	15
1.5.2.10 Un-propped structure or member.....	15
1.5.2.11 Un-cracked flexural stiffness.....	15
1.5.2.12 Cracked flexural stiffness.....	15
1.5.2.13 Prestress.....	15
1.5.2.14 Filler beam deck.....	15
1.5.2.15 Composite plate.....	15
1.6 Symbols .....	15
<b>Section 2 Basis of design</b> .....	<b>22</b>
2.1 Requirements.....	22
2.2 Principles of limit states design.....	22
2.3 Basic variables.....	22
2.3.1 Actions and environmental influences.....	22
2.3.2 Material and product properties.....	22
2.3.3 Classification of actions.....	22
2.4 Verification by the partial factor method.....	23
2.4.1 Design values.....	23
2.4.1.1 Design values of actions.....	23
2.4.1.2 Design values of material or product properties.....	23
2.4.1.3 Design values of geometrical data.....	23
2.4.1.4 Design resistances .....	23
2.4.2 Combination of actions.....	24
2.4.3 Verification of static equilibrium (EQU).....	24

<b>Section 3 Materials</b> .....	<b>24</b>
3.1 Concrete.....	24
3.2 Reinforcing steel for bridges.....	24
3.3 Structural steel for bridges .....	24
3.4 Connecting devices.....	24
3.4.1 General.....	24
3.4.2 Headed stud shear connectors.....	24
3.5 Prestressing steel and devices.....	25
3.6 Tension components in steel.....	25
<b>Section 4 Durability</b> .....	<b>25</b>
4.1 General.....	25
4.2 Corrosion protection at the steel-concrete interface in bridges.....	25
<b>Section 5 Structural analysis</b> .....	<b>25</b>
5.1 Structural modelling for analysis.....	25
5.1.1 Structural modelling and basic assumptions.....	25
5.1.2 Joint modelling.....	25
5.1.3 Ground-structure interaction.....	26
5.2 Structural stability.....	26
5.2.1 Effects of deformed geometry of the structure.....	26
5.2.2 Methods of analysis for bridges.....	26
5.3 Imperfections.....	26
5.3.1 Basis.....	26
5.3.2 Imperfections for bridges.....	27
5.4 Calculation of action effects.....	27
5.4.1 Methods of global analysis.....	27
5.4.1.1 General.....	27
5.4.1.2 Effective width of flanges for shear lag.....	28
5.4.2 Linear elastic analysis.....	29
5.4.2.1 General.....	29
5.4.2.2 Creep and shrinkage.....	29
5.4.2.3 Effects of cracking of concrete.....	30
5.4.2.4 Stages and sequence of construction.....	31
5.4.2.5 Temperature effects.....	31
5.4.2.6 Pre-stressing by controlled imposed deformations.....	32
5.4.2.7 Pre-stressing by tendons.....	32
5.4.2.8 Tension members in composite bridges.....	32
5.4.2.9 Filler beam decks for bridges.....	33
5.4.3 Non-linear global analysis for bridges.....	34
5.4.4 Combination of global and local action effects.....	34
5.5 Classification of cross-sections.....	34
5.5.1 General.....	34
5.5.2 Classification of composite sections without concrete encasement .....	35
5.5.3 Classification of sections of filler beam decks for bridges.....	36
<b>Section 6 Ultimate limit states</b> .....	<b>36</b>
6.1 Beams .....	36
6.1.1 Beams in bridges - General .....	36
6.1.2 Effective width for verification of cross-sections.....	36



6.2 Resistances of cross-sections of beams.....	36
6.2.1 Bending resistance.....	36
6.2.1.1 General.....	36
6.2.1.2 Plastic resistance moment $M_{pl,Rd}$ of a composite cross-section.....	37
6.2.1.3 Additional rules for beams in bridges.....	38
6.2.1.4 Non-linear resistance to bending.....	38
6.2.1.5 Elastic resistance to bending.....	40
6.2.2 Resistance to vertical shear.....	40
6.2.2.1 Scope.....	40
6.2.2.2 Plastic resistance to vertical shear.....	41
6.2.2.3 Shear buckling resistance.....	41
6.2.2.4 Bending and vertical shear.....	41
6.2.2.5 Additional rules for beams in bridges.....	41
6.3 Filler beam decks.....	42
6.3.1 Scope.....	42
6.3.2 General.....	43
6.3.3 Bending moments.....	43
6.3.4 Vertical shear.....	43
6.3.5 Resistance and stability of steel beams during execution.....	44
6.4 Lateral-torsional buckling of composite beams.....	44
6.4.1 General.....	44
6.4.2 Beams in bridges with uniform cross-sections in Class 1, 2 and 3.....	44
6.4.3 General methods for buckling of members and frames.....	46
6.4.3.1 General method.....	46
6.4.3.2 Simplified method.....	46
6.5 Transverse forces on webs.....	46
6.5.1 General.....	46
6.5.2 Flange-induced buckling of webs.....	46
6.6 Shear connection.....	46
6.6.1 General.....	46
6.6.1.1 Basis of design.....	46
6.6.1.2 Ultimate limit states other than fatigue.....	47
6.6.2 Longitudinal shear force in beams for bridges.....	47
6.6.2.1 Beams in which elastic or non-linear theory is used for resistances of cross-sections.....	47
6.6.2.2 Beams in bridges with some cross-sections in Class 1 or 2 and inelastic behaviour.....	48
6.6.2.3 Local effects of concentrated longitudinal shear force due to introduction of longitudinal forces.....	49
6.6.2.4 Local effects of concentrated longitudinal shear force at sudden change of cross-section.....	51
6.6.3 Headed stud connectors in solid slabs and concrete encasement.....	52
6.6.3.1 Design resistance.....	52
6.6.3.2 Influence of tension on shear resistance.....	53
6.6.4 Headed studs that cause splitting in the direction of the slab thickness.....	53
6.6.5 Detailing of the shear connection and influence of execution.....	53
6.6.5.1 Resistance to separation.....	53
6.6.5.2 Cover and concreting.....	53
6.6.5.3 Local reinforcement in the slab.....	54
6.6.5.4 Haunches other than formed by profiled steel sheeting.....	54

6.6.5.5 Spacing of connectors.....	54
6.6.5.6 Dimensions of the steel flange.....	55
6.6.5.7 Headed stud connectors.....	55
6.6.6 Longitudinal shear in concrete slabs.....	56
6.6.6.1 General.....	56
6.6.6.2 Design resistance to longitudinal shear.....	56
6.6.6.3 Minimum transverse reinforcement.....	57
6.7 Composite columns and composite compression members.....	57
6.7.1 General.....	57
6.7.2 General method of design .....	59
6.7.3 Simplified method of design.....	59
6.7.3.1 General and scope.....	59
6.7.3.2 Resistance of cross-sections.....	60
6.7.3.3 Effective flexural stiffness, steel contribution ratio and relative slenderness.....	62
6.7.3.4 Methods of analysis and member imperfections.....	63
6.7.3.5 Resistance of members in axial compression.....	64
6.7.3.6 Resistance of members in combined compression and uniaxial bending.....	66
6.7.3.7 Combined compression and biaxial bending.....	66
6.7.4 Shear connection and load introduction.....	67
6.7.4.1 General.....	67
6.7.4.2 Load introduction.....	67
6.7.4.3 Longitudinal shear outside the areas of load introduction.....	70
6.7.5 Detailing Provisions.....	71
6.7.5.1 Concrete cover of steel profiles and reinforcement.....	71
6.7.5.2 Longitudinal and transverse reinforcement.....	71
6.8 Fatigue.....	72
6.8.1 General.....	72
6.8.2 Partial factors for fatigue assessment of bridges.....	72
6.8.3 Fatigue strength.....	72
6.8.4 Internal forces and fatigue loadings.....	73
6.8.5 Stresses .....	73
6.8.5.1 General.....	73
6.8.5.2 Concrete.....	74
6.8.5.3 Structural steel.....	74
6.8.5.4 Reinforcement.....	74
6.8.5.5 Shear connection.....	75
6.8.5.6 Stresses in reinforcement and prestressing steel in members prestressed by bonded tendons.....	75
6.8.6 Stress ranges.....	75
6.8.6.1 Structural steel and reinforcement.....	75
6.8.6.2 Shear connection.....	76
6.8.7 Fatigue assessment based on nominal stress ranges.....	76
6.8.7.1 Structural steel, reinforcement and concrete.....	76
6.8.7.2 Shear connection.....	77
6.9 Tension members in composite bridges.....	78

<b>Section 7 Serviceability limit states</b> .....	<b>78</b>
7.1 General.....	78
7.2 Stresses.....	79
7.2.1 General.....	79
7.2.2 Stress limitation for bridges.....	79
7.2.3 Web breathing.....	79
7.3 Deformations in bridges.....	80
7.3.1 Deflections.....	80
7.3.2 Vibrations.....	80
7.4 Cracking of concrete.....	80
7.4.1 General.....	80
7.4.2 Minimum reinforcement.....	81
7.4.3 Control of cracking due to direct loading.....	83
7.5 Filler beam decks.....	84
7.5.1 General.....	84
7.5.2 Cracking of concrete.....	84
7.5.3 Minimum reinforcement.....	84
7.5.4 Control of cracking due to direct loading.....	84
<b>Section 8 Precast concrete slabs in composite bridges</b> .....	<b>85</b>
8.1 General.....	85
8.2 Actions.....	85
8.3 Design, analysis and detailing of the bridge slab.....	85
8.4 Interface between steel beam and concrete slab.....	85
8.4.1 Bedding and tolerances.....	85
8.4.2 Corrosion.....	85
8.4.3 Shear connection and transverse reinforcement.....	85
<b>Section 9 Composite plates in bridges</b> .....	<b>86</b>
9.1 General.....	86
9.2 Design for local effects.....	86
9.3 Design for global effects.....	86
9.4 Design of shear connectors.....	87
<b>Annex C (Informative) Headed studs that cause splitting forces in the direction of the slab thickness</b> .....	<b>89</b>
C.1 Design resistance and detailing .....	89
C.2 Fatigue strength.....	90



## Foreword

This document (EN 1994-2:2005), Eurocode 4: Design of composite steel and concrete structures, Part 2: General rules and rules for bridges, has been prepared on behalf of Technical Committee CEN/TC 250 "Structural Eurocodes", the Secretariat of which is held by BSI.

This European Standard shall be given the status of a national standard, either by publication of an identical text or by endorsement, at the latest by April 2006, and conflicting national standards shall be withdrawn at the latest by March 2010.

This document supersedes ENV 1994-2:1994.

CEN/TC 250 is responsible for all Structural Eurocodes.

According to the CEN/CENELEC Internal Regulations, the national standards organizations of the following countries are bound to implement this European Standard: Austria, Belgium, Cyprus, Czech Republic, Denmark, Estonia, Finland, France, Germany, Greece, Hungary, Iceland, Ireland, Italy, Latvia, Lithuania, Luxembourg, Malta, the Netherlands, Norway, Poland, Portugal, Slovakia, Slovenia, Spain, Sweden, Switzerland and the United Kingdom.

## Background of the Eurocode programme

In 1975, the Commission of the European Community decided on an action programme in the field of construction, based on article 95 of the Treaty. The objective of the programme was the elimination of technical obstacles to trade and the harmonisation of technical specifications.

Within this action programme, the Commission took the initiative to establish a set of harmonised technical rules for the design of construction works which, in a first stage, would serve as an alternative to the national rules in force in the Member States and, ultimately, would replace them.

For fifteen years, the Commission, with the help of a Steering Committee with Representatives of Member States, conducted the development of the Eurocodes programme, which led to the first generation of European codes in the 1980s.

In 1989, the Commission and the Member States of the EU and EFTA decided, on the basis of an agreement<sup>1</sup> between the Commission and CEN, to transfer the preparation and the publication of the Eurocodes to CEN through a series of Mandates, in order to provide them with a future status of European Standard (EN). This links *de facto* the Eurocodes with the provisions of all the Council's Directives and/or Commission's Decisions dealing with European standards (*e.g.* the Council Directive 89/106/EEC on construction products - CPD - and Council Directives 93/37/EEC, 92/50/EEC and 89/440/EEC on public works and services and equivalent EFTA Directives initiated in pursuit of setting up the internal market).

The Structural Eurocode programme comprises the following standards generally consisting of a number of Parts:

EN 1990	Eurocode :	Basis of Structural Design
EN 1991	Eurocode 1:	Actions on structures
EN 1992	Eurocode 2:	Design of concrete structures

<sup>1</sup> Agreement between the Commission of the European Communities and the European Committee for Standardisation (CEN) concerning the work on EUROCODES for the design of building and civil engineering works (BC/CEN/03/89).

EN 1993	Eurocode 3:	Design of steel structures
EN 1994	Eurocode 4:	Design of composite steel and concrete structures
EN 1995	Eurocode 5:	Design of timber structures
EN 1996	Eurocode 6:	Design of masonry structures
EN 1997	Eurocode 7:	Geotechnical design
EN 1998	Eurocode 8:	Design of structures for earthquake resistance
EN 1999	Eurocode 9:	Design of aluminium structures

Eurocode standards recognise the responsibility of regulatory authorities in each Member State and have safeguarded their right to determine values related to regulatory safety matters at national level where these continue to vary from State to State.

## Status and field of application of Eurocodes

The Member States of the EU and EFTA recognise that Eurocodes serve as reference documents for the following purposes:

- as a means to prove compliance of building and civil engineering works with the essential requirements of Council Directive 89/106/EEC, particularly Essential Requirement N°1 – Mechanical resistance and stability – and Essential Requirement N°2 – Safety in case of fire ;
- as a basis for specifying contracts for construction works and related engineering services ;
- as a framework for drawing up harmonised technical specifications for construction products (ENs and ETAs)

The Eurocodes, as far as they concern the construction works themselves, have a direct relationship with the Interpretative Documents<sup>2</sup> referred to in Article 12 of the CPD, although they are of a different nature from harmonised product standards<sup>3</sup>. Therefore, technical aspects arising from the Eurocodes work need to be adequately considered by CEN Technical Committees and/or EOTA Working Groups working on product standards with a view to achieving full compatibility of these technical specifications with the Eurocodes.

The Eurocode standards provide common structural design rules for everyday use for the design of whole structures and component products of both a traditional and an innovative nature. Unusual forms of construction or design conditions are not specifically covered and additional expert consideration will be required by the designer in such cases.

## National Standards implementing Eurocodes

The National Standards implementing Eurocodes will comprise the full text of the Eurocode (including any annexes), as published by CEN, which may be preceded by a National title page and National foreword, and may be followed by a National annex.

---

<sup>2</sup> According to Art. 3.3 of the CPD, the essential requirements (ERs) shall be given concrete form in interpretative documents for the creation of the necessary links between the essential requirements and the mandates for harmonised ENs and ETAGs/ETAs.

<sup>3</sup> According to Art. 12 of the CPD the interpretative documents shall :

- give concrete form to the essential requirements by harmonising the terminology and the technical bases and indicating classes or levels for each requirement where necessary ;
- indicate methods of correlating these classes or levels of requirement with the technical specifications, *e.g.* methods of calculation and of proof, technical rules for project design, etc. ;
- serve as a reference for the establishment of harmonised standards and guidelines for European technical approvals.

The Eurocodes, *de facto*, play a similar role in the field of the ER 1 and a part of ER 2.

The National annex may only contain information on those parameters which are left open in the Eurocode for national choice, known as Nationally Determined Parameters, to be used for the design of buildings and civil engineering works to be constructed in the country concerned, *i.e.*:

- values and/or classes where alternatives are given in the Eurocode,
- values to be used where a symbol only is given in the Eurocode,
- country specific data (geographical, climatic, etc.), e.g. snow map,
- the procedure to be used, where alternative procedures are given in the Eurocode.

It may also contain

- decisions on the use of informative annexes, and
- references to non-contradictory complementary information to assist the user to apply the Eurocode.

### **Links between Eurocodes and harmonised technical specifications (ENs and ETAs) for products**

There is a need for consistency between the harmonised technical specifications for construction products and the technical rules for works<sup>4</sup>. Furthermore, all the information accompanying the CE Marking of the construction products which refer to Eurocodes shall clearly mention which Nationally Determined Parameters have been taken into account.

### **Additional information specific to EN 1994-2**

EN 1994-2 describes the Principles and requirements for safety, serviceability and durability of composite steel and concrete structures, together with specific provisions for bridges. It is based on the limit state concept used in conjunction with a partial factor method.

EN 1994-2 is intended for use by:

- committees drafting other standards for structural design and related product, testing and execution standards ;
- clients (e.g. for the formulation of their specific requirements on reliability levels and durability);
- designers and constructors ;
- relevant authorities.

EN 1994-2 contains the general rules from EN 1994-1-1 and specific rules for the design of composite steel and concrete bridges or composite members of bridges.

EN 1994-2 is intended to be used with EN 1990, the relevant parts of EN 1991, EN 1993 for the design of steel structures and EN 1992 for the design of concrete structures.

Numerical values for partial factors and other reliability parameters are recommended as basic values that provide an acceptable level of reliability. They have been selected assuming that an appropriate level of workmanship and of quality management applies. When EN 1994-2 is used as a base document by other CEN/TCs the same values need to be taken.

---

<sup>4</sup> sec Art.3.3 and Art.12 of the CPD, as well as clauses 4.2, 4.3.1, 4.3.2 and 5.2 of ID 1.

## National Annex for EN 1994-2

This standard gives alternative procedures, values and recommendations for classes with notes indicating where national choices may have to be made. Therefore, the National Standard implementing EN 1994-2 should have a National annex containing all Nationally Determined Parameters to be used for the design of bridges to be constructed in the relevant country.

National choice is allowed in the general rules coming from EN 1994-1-1: 2004 through the following clauses:

- 2.4.1.1(1)
- ▣<sub>AC1</sub> - 2.4.1.2(5)P ▣<sub>AC1</sub>
- 6.6.3.1(1)

National choice is allowed for the specific rules for bridges through the following clauses:

- 1.1.3(3)
- ▣<sub>AC1</sub> 2.4.1.2(6)P ▣<sub>AC1</sub>
- 5.4.4(1)
- 6.2.1.5(9)
- 6.2.2.5(3)
- 6.3.1(1)
- 6.6.1.1(13)
- 6.8.1(3)
- 6.8.2(1)
- 7.4.1(4)
- 7.4.1(6)
- 8.4.3(3)

## Section 1 General

### 1.1 Scope

#### 1.1.1 Scope of Eurocode 4

(1) Eurocode 4 applies to the design of composite structures and members for buildings and civil engineering works. It complies with the principles and requirements for the safety and serviceability of structures, the basis of their design and verification that are given in EN 1990: 2002 – Basis of structural design.

(2) Eurocode 4 is concerned only with requirements for resistance, serviceability, durability and fire resistance of composite structures. Other requirements, e.g. concerning thermal or sound insulation, are not considered.

(3) Eurocode 4 is intended to be used in conjunction with:

EN 1990 Basis of structural design

EN 1991 Actions on structures

ENs, hENs, ETAGs and ETAs for construction products relevant for composite structures

EN 1090 Execution of steel structures and aluminium structures

EN 13670 Execution of concrete structures

EN 1992 Design of concrete structures

EN 1993 Design of steel structures

EN 1997 Geotechnical design

EN 1998 Design of structures for earthquake resistance

(4) Eurocode 4 is subdivided in various parts:

Part 1-1: General rules and rules for buildings

Part 1-2: Structural fire design

Part 2: General rules and rules for bridges.

#### 1.1.2 Scope of Part 1-1 of Eurocode 4

(1) Part 1-1 of Eurocode 4 gives a general basis for the design of composite structures together with specific rules for buildings.

(2) The following subjects are dealt with in Part 1-1:

Section 1: General

Section 2: Basis of design

Section 3: Materials

Section 4: Durability

Section 5: Structural analysis

Section 6: Ultimate limit states

Section 7: Serviceability limit states

Section 8: Composite joints in frames for buildings

Section 9: Composite slabs with profiled steel sheeting for buildings

### 1.1.3 Scope of Part 2 of Eurocode 4

(1) Part 2 of Eurocode 4 gives design rules for steel-concrete composite bridges or members of bridges, additional to the general rules in EN 1994-1-1. Cable stayed bridges are not fully covered by this part.

(2) The following subjects are dealt with in Part 2:

- Section 1: General
- Section 2: Basis of design
- Section 3: Materials
- Section 4: Durability
- Section 5: Structural analysis
- Section 6: Ultimate limit states
- Section 7: Serviceability limit states
- Section 8: Decks with precast concrete slabs
- Section 9: Composite plates in bridges

(3) Provisions for shear connectors are given only for welded headed studs.

**NOTE:** Reference to guidance for other types of shear connectors may be given in the National Annex.

## 1.2 Normative references

The following normative documents contain provisions which, through references in this text, constitute provisions of this European standard. For dated references, subsequent amendments to or revisions of any of these publications do not apply. However, parties to agreements based on this European standard are encouraged to investigate the possibility of applying the most recent editions of the normative documents indicated below. For undated references the latest edition of the normative document referred to applies.

### 1.2.1 General reference standards

- |                         |   |
|-------------------------|---|
| EN 1090-2 <sup>1)</sup> | Execution of steel structures and aluminium Structures-Part 2: Technical requirements for the execution of steel structures |
| EN 1990: 2002           | Basis of structural design.   |

### 1.2.2 Other reference standards

- |  |  |
|--|--|
| EN 1992-1-1: 2004  | Eurocode 2: Design of concrete structures- Part 1-1: General rules and rules for buildings     |
| EN 1993-1-1: 2005  | Eurocode 3: Design of steel structures – Part 1-1: General rules and rules for buildings       |
| <span style="border: 1px solid black; padding: 0 2px;">AC1</span> EN 1993-1-3:2006 <span style="border: 1px solid black; padding: 0 2px;">AC1</span> | Eurocode 3: Design of steel structures – Part 1-3: Cold-formed thin gauge members and sheeting |
| <span style="border: 1px solid black; padding: 0 2px;">AC1</span> EN 1993-1-5:2006 <span style="border: 1px solid black; padding: 0 2px;">AC1</span> | Eurocode 3: Design of steel structures- Part 1-5: Plated structural elements                   |

AC1 Footnote deleted AC1

- EN 1993-1-8: 2005 Eurocode 3: Design of steel structures – Part 1-8: Design of joints
- EN 1993-1-9: 2005 Eurocode 3: Design of steel structures – Part 1-9: Fatigue strength of steel structures
- EN 1993-1-11:2006 Eurocode 3: Design of steel structures – Part 1-11: Design of structures with tension components
- EN 10025-1: 2004 Hot-rolled products of structural steels - Part 1: General delivery conditions
- EN 10025-2: 2004 Hot-rolled products of structural steels - Part 2: Technical delivery conditions for non-alloy structural steels
- EN 10025-3: 2004 Hot-rolled products of structural steels - Part 3: Technical delivery conditions for normalized/normalized rolled weldable fine grain structural steels
- EN 10025-4: 2004 Hot-rolled products of structural steels - Part 4: Technical delivery conditions for thermomechanical rolled weldable fine grain structural steels
- EN 10025-5: 2004 Hot-rolled products of structural steels – Part 5: Technical delivery conditions for structural steels with improved atmospheric corrosion resistance
- EN 10025-6: 2004 Hot-rolled products of structural steels – Part 6: Technical delivery conditions for flat products of high yield strength structural steels in the quenched and tempered condition
- EN 10326: 2004 Continuously hot-dip coated strip and sheet of structural steel - Technical delivery conditions
- EN 10149-2: 1995 Hot-rolled flat products made of high yield strength steels for cold-forming - Part 2: Delivery conditions for thermomechanically rolled steels
- EN 10149-3: 1995 Hot-rolled flat products made of high yield strength steels for cold-forming – Part 3: Delivery conditions for normalised or normalised rolled steels
- EN ISO 13918: 1998 Studs and ceramic ferrules for arc stud welding
- EN ISO 14555: 1998 Arc stud welding of metallic materials

### 1.2.3 Additional general and other reference standards for composite bridges

- EN 1990:2002, Annex A2 Basis of structural design: Application for bridges
- EN 1991-1-5: 2003 Actions on structures. Part 1-5: General actions – Thermal actions
- EN 1991-1-6: 2005 Actions on structures. Part 1-6: General actions – Actions during execution
- EN 1991-2: 2003 Actions on structures: Part 2: Traffic loads on bridges
- EN 1992-2:2005 Design of concrete structures. Part 2 – Bridges
- EN 1993-2:2006 Design of steel structures. Part 2 – Bridges

### 1.3 Assumptions

- (1) In addition to the general assumptions of EN 1990: 2002 the following assumptions apply:
- those given in clauses 1.3 of EN1992-1-1: 2004 and EN1993-1-1: 2005.



## **1.4 Distinction between principles and application rules**

(1) The rules in EN 1990: 2002, 1.4 apply.

## **1.5 Definitions**

### **1.5.1 General**

(1) The terms and definitions given in EN 1990: 2002, 1.5, EN 1992-1-1: 2004, 1.5 and EN 1993-1-1: 2005, 1.5 apply.

### **1.5.2 Additional terms and definitions used in this Standard**

#### **1.5.2.1 Composite member**

A structural member with components of concrete and of structural or cold-formed steel, interconnected by shear connection so as to limit the longitudinal slip between concrete and steel and the separation of one component from the other.

#### **1.5.2.2 Shear connection**

An interconnection between the concrete and steel components of a composite member that has sufficient strength and stiffness to enable the two components to be designed as parts of a single structural member.

#### **1.5.2.3 Composite behaviour**

Behaviour which occurs after the shear connection has become effective due to hardening of concrete.

#### **1.5.2.4 Composite beam**

A composite member subjected mainly to bending.

#### **1.5.2.5 Composite column**

A composite member subjected mainly to compression or to compression and bending.

#### **1.5.2.6 Composite slab**

A slab in which profiled steel sheets are used initially as permanent shuttering and subsequently combine structurally with the hardened concrete and act as tensile reinforcement in the finished floor.

#### **1.5.2.7 Composite frame**

A framed structure in which some or all of the elements are composite members and most of the remainder are structural steel members.

#### **1.5.2.8 Composite joint**

A joint between a composite member and another composite, steel or reinforced concrete member, in which reinforcement is taken into account in design for the resistance and the stiffness of the joint.

### 1.5.2.9 Propped structure or member

A structure or member where the weight of concrete elements is applied to the steel elements which are supported in the span, or is carried independently until the concrete elements are able to resist stresses.

### 1.5.2.10 Un-propped structure or member

A structure or member in which the weight of concrete elements is applied to steel elements which are unsupported in the span.

### 1.5.2.11 Un-cracked flexural stiffness

The stiffness  $E_a I_1$  of a cross-section of a composite member where  $I_1$  is the second moment of area of the effective equivalent steel section calculated assuming that concrete in tension is un-cracked.

### 1.5.2.12 Cracked flexural stiffness

The stiffness  $E_a I_2$  of a cross-section of a composite member where  $I_2$  is the second moment of area of the effective equivalent steel section calculated neglecting concrete in tension but including reinforcement.

### 1.5.2.13 Prestress

The process of applying compressive stresses to the concrete part of a composite member, achieved by tendons or by controlled imposed deformations.

### 1.5.2.14 Filler beam deck

A deck consisting of a reinforced concrete slab and partially concrete-encased rolled or welded steel beams, having their bottom flange on the level of the slab bottom.

### 1.5.2.15 Composite plate

Composite member consisting of a flat bottom steel plate connected to a concrete slab, in which both the length and width are much larger than the thickness of the composite plate.

## 1.6 Symbols

For the purpose of this Standard the following symbols apply.

*Latin upper case letters*

$A$	Cross-sectional area of the effective composite section neglecting concrete in tension
$A_a$	Cross-sectional area of the structural steel section
$A_b$	Cross-sectional area of bottom transverse reinforcement
$A_{bh}$	Cross-sectional area of bottom transverse reinforcement in a haunch
$A_c$	Cross-sectional area of concrete
$A_{ct}$	Cross-sectional area of the tensile zone of the concrete
$A_{fc}$	Cross-sectional area of the compression flange
$A_p$	Area of prestressing steel
$A_s$	Cross-sectional area of reinforcement
$A_{sf}$	Cross-sectional area of transverse reinforcement
$A_t$	Cross-sectional area of top transverse reinforcement

$A_v$	Shear area of a structural steel section
$A_1$	Loaded area under the gusset plate
$E_a$	Modulus of elasticity of structural steel
$E_{c,eff}$	Effective modulus of elasticity for concrete
$E_{cm}$	Secant modulus of elasticity of concrete
$E_s$	Design value of modulus of elasticity of reinforcing steel
$(EA)_{eff}$	Effective longitudinal stiffness of cracked concrete
$(EI)_{eff}$	Effective flexural stiffness for calculation of relative slenderness
$(EI)_{eff,II}$	Effective flexural stiffness for use in second-order analysis
$(EI)_2$	Cracked flexural stiffness per unit width of the concrete or composite slab
$F_d$	Component in the direction of the steel beam of the design force of a bonded or unbonded tendon applied after the shear connection has become effective
$F_\ell$	Design longitudinal force per stud
$F_t$	Design transverse force per stud
$F_{ten}$	Design tensile force per stud
$G_a$	Shear modulus of structural steel
$G_c$	Shear modulus of concrete
$I$	Second moment of area of the effective composite section neglecting concrete in tension
$I_a$	Second moment of area of the structural steel section
$I_{at}$	St. Venant torsion constant of the structural steel section
$I_c$	Second moment of area of the un-cracked concrete section
$I_{eff}$	Effective second moment of area of filler beams
$I_s$	Second moment of area of the steel reinforcement
$I_1$	Second moment of area of the effective equivalent steel section assuming that the concrete in tension is un-cracked
$I_2$	Second moment of area of the effective equivalent steel section neglecting concrete in tension but including reinforcement
$K_c, K_{c,II}$	Correction factors to be used in the design of composite columns
$K_0$	Calibration factor to be used in the design of composite columns
$L$	Length; span; effective span
$L_e$	Equivalent span
$L_i$	Span
$L_{A-B}$	Length of inelastic region, between points A and B, corresponding to $M_{cl,Rd}$ and $M_{Ed,max}$ , respectively
$L_v$	Length of shear connection
$M$	Bending moment
$M_a$	Contribution of the structural steel section to the design plastic resistance moment of the composite section
$M_{a,Ed}$	Design bending moment applied to the structural steel section
$M_{b,Rd}$	Design value of the buckling resistance moment of a composite beam
$M_{c,Ed}$	The part of the design bending moment acting on the composite section
$M_{cr}$	Elastic critical moment for lateral-torsional buckling of a composite beam
$M_{Ed}$	Design bending moment
$M_{Ed,max}$	Total design bending moment applied to the steel and composite member
$M_{Ed,max,f}$	Maximum bending moment or internal force due to fatigue loading
$M_{Ed,min,f}$	Minimum bending moment due to fatigue loading
$M_{cl,Rd}$	Design value of the elastic resistance moment of the composite section
$M_{f,Rd}$	Design resistance moment to 5.2.6.1 of EN 1993-1-5

$M_{\max,Rd}$	Maximum design value of the resistance moment in the presence of a compressive normal force
$M_{perm}$	Most adverse bending moment for the characteristic combination
$M_{pl,a,Rd}$	Design value of the plastic resistance moment of the structural steel section
$M_{pl,N,Rd}$	Design value of the plastic resistance moment of the composite section taking into account the compressive normal force
$M_{pl,Rd}$	Design value of the plastic resistance moment of the composite section with full shear connection
$M_{pl,y,Rd}$	Design value of the plastic resistance moment about the $y$ - $y$ axis of the composite section with full shear connection
$M_{pl,z,Rd}$	Design value of the plastic resistance moment about the $z$ - $z$ axis of the composite section with full shear connection
$M_{Rd}$	Design value of the resistance moment of a composite section
$M_{Rk}$	Characteristic value of the resistance moment of a composite section or joint
$M_{y,Ed}$	Design bending moment applied to the composite section about the $y$ - $y$ axis
$M_{z,Ed}$	Design bending moment applied to the composite section about the $z$ - $z$ axis
$N$	Compressive normal force; number of stress range cycles; number of shear connectors
$N_a$	Design value of the normal force in the structural steel section of a composite beam
$N_c$	Design value of the compressive normal force in the concrete flange
$N_{cd}$	Design compressive force in concrete slab corresponding to $M_{Ed,max}$
$N_{c,f}$	Design value of the compressive normal force in the concrete flange with full shear connection
$N_{c,el}$	Compressive normal force in the concrete flange corresponding to $M_{cl,Rd}$
$N_{cr,eff}$	Elastic critical load of a composite column corresponding to an effective flexural stiffness
$N_{cr}$	Elastic critical normal force
$N_{cl}$	Design value of normal force calculated for load introduction
$N_{Ed}$	Design value of the compressive normal force
$N_{Ed,scr}$	Normal force of concrete tension member for SLS
$N_{Ed,ult}$	Normal force of concrete tension member for ULS
$N_{G,Ed}$	Design value of the part of the compressive normal force that is permanent
$N_{pl,a}$	Design value of the plastic resistance of the structural steel section to normal force
$N_{pl,Rd}$	Design value of the plastic resistance of the composite section to compressive normal force
$N_{pl,Rk}$	Characteristic value of the plastic resistance of the composite section to compressive normal force
$N_{pm,Rd}$	Design value of the resistance of the concrete to compressive normal force
$N_R$	Number of stress-range cycles
$N_s$	Design value of the plastic resistance of the steel reinforcement to normal force
$N_{sd}$	Design value of the plastic resistance of the reinforcing steel to tensile normal force
$N_{s,el}$	Tensile force in cracked concrete slab corresponding to $M_{cl,Rd}$ taking into account the effects of tension stiffening
$P_{Ed}$	Longitudinal force on a connector at distance $x$ from the nearest web
$P_{f,Rd}$	Design value of the shear resistance of a single stud connector corresponding to $F_t$
$P_{Rd}$	Design value of the shear resistance of a single connector
$P_{Rk}$	Characteristic value of the shear resistance of a single connector
$P_{t,Rd}$	Design value of the shear resistance of a single stud connector corresponding to $F_t$
$V_{a,Ed}$	Design value of the shear force acting on the structural steel section

$V_{b,Rd}$	Design value of the shear buckling resistance of a steel web
$V_{c,Ed}$	Design value of the shear force acting on the reinforced concrete cross-section of a filler beam
$V_{Ed}$	Design value of the shear force acting on the composite section
$V_L$	Longitudinal shear force, acting along the steel-concrete flange interface
$V_{L,Ed}$	Longitudinal shear force acting on length $L_{A-B}$ of the inelastic region
$V_{pl,Rd}$	Design value of the plastic resistance of the composite section to vertical shear
$V_{pl,a,Rd}$	Design value of the plastic resistance of the structural steel section to vertical shear
$V_{p,Rd}$	Design value of the resistance of a composite slab to punching shear
$V_{Rd}$	Design value of the resistance of the composite section to vertical shear

*Latin lower case letters*

$a$	Spacing between parallel beams; diameter or width; distance
$a_w$	Steel flange projection outside the web of the beam
$b$	Width of the flange of a steel section; width of slab, half the distance between adjacent webs, or the distance between the web and the free edge of the flange
$b_{eff}$	Total effective width
$b_{eff,1}$	Effective width at mid-span for a span supported at both ends
$b_{eff,2}$	Effective width at an internal support
$b_{ci}$	Effective width of the concrete flange on each side of the web, effective width of composite bottom flange of a box section
$b_f$	Width of the flange of a steel section
$b_i$	Geometric width of the concrete flange on each side of the web
$b_0$	Distance between the centres of the outstand shear connectors; mean width of a concrete rib (minimum width for re-entrant sheeting profiles); width of haunch
$c$	Width of the outstand of a steel flange; effective perimeter of reinforcing bar
$c_{st}$	Concrete cover above the steel beams of filler beam decks
$c_y, c_z$	Thickness of concrete cover
$d$	Clear depth of the web of the structural steel section; diameter of the shank of a stud connector; overall diameter of circular hollow steel section; minimum transverse dimension of a column
$d_{do}$	Diameter of the weld collar to a stud connector
$d_s$	Distance between the steel reinforcement in tension to the extreme fibre of the composite slab in compression; distance between the longitudinal reinforcement in tension and the centroid of the beam's steel section
$e_D$	Edge distance
$e_d$	Either of $2e_h$ or $2e_v$
$e_g$	Gap between the reinforcement and the end plate in a composite column
$e_h$	Lateral distance from the point of application of force $F_d$ to the relevant steel web, if $F_d$ is applied to the concrete slab
$e_v$	Vertical distance from the point of application of force $F_d$ to the plane of shear connection concerned, if $F_d$ is applied to the steel element
$f_{cd}$	Design value of the cylinder compressive strength of concrete according to 2.4.1.2
$f_{ck}$	Characteristic value of the cylinder compressive strength of concrete at 28 days

$f_{cm}$	Mean value of the measured cylinder compressive strength of concrete
$f_{ct,eff}$	Mean value of the effective tensile strength of the concrete
$f_{ctm}$	Mean value of the axial tensile strength of concrete
$f_{ct,0}$	Reference strength for concrete in tension
$f_{ictm}$	Mean value of the axial tensile strength of lightweight concrete
$f_{pd}$	Limiting stress of prestressing tendons according to 3.3.3 of EN1992-1-1
$f_{pk}$	characteristic value of yield strength of prestressing tendons
$f_{sd}$	Design value of the yield strength of reinforcing steel
$f_{sk}$	Characteristic value of the yield strength of reinforcing steel
$f_u$	Specified ultimate tensile strength
$f_y$	Nominal value of the yield strength of structural steel
$f_{yd}$	Design value of the yield strength of structural steel
$h$	Overall depth; thickness
$h_a$	Depth of the structural steel section
$h_c$	thickness of the concrete flange;
$h_n$	Position of neutral axis
$h_s$	Depth between the centroids of the flanges of the structural steel section
$h_{sc}$	Overall nominal height of a stud connector
$k$	Amplification factor for second-order effects; coefficient; empirical factor for design shear resistance
$k_c$	Coefficient
$k_s$	reduction factor for shear resistance of stud connector
$k_\phi$	Parameter
$k_1$	Flexural stiffness of the cracked concrete slab
$k_2$	Flexural stiffness of the web
$\ell_0$	Load introduction length
$m$	Slope of fatigue strength curve; empirical factor for design shear resistance
$n$	Modular ratio; number of shear connectors
$n_L$	Modular ratio depending on the type of loading
$n_0$	Modular ratio for short-term loading
$n_{0G}$	Modular ratio (shear moduli) for short term loading
$n_{tot}$	See 9.4
$n_{LG}$	Modular ratio (shear moduli) for long term loading
$n_w$	See 9.4
$r$	Ratio of end moments
$s$	Longitudinal spacing centre-to-centre of the stud shear connectors
$s_f$	Clear distance between the upper flanges of the steel beams of filler beam decks
$s_t$	Transverse spacing centre-to-centre of the stud shear connectors
$s_w$	Spacing of webs of steel beams of filler beam decks
$t$	Age; thickness
$t_w$	Thickness of the web of the structural steel section
$t_f$	Thickness of the steel flange of the steel beams of filler beam decks
$t_0$	Age at loading
$v_{Ed}$	Design longitudinal shear stress
$v_{L,Ed}$	Design longitudinal shear force per unit length at the interface between steel and concrete

$V_{L, Ed, max}$	Maximum design longitudinal shear force per unit length at the interface between steel and concrete
$w_k$	Design value of crack width
$x$	Distance of a shear connector from the nearest web
$x_{pl}$	Distance between the plastic neutral axis and the extreme fibre of the concrete slab in compression
$y$	Cross-section axis parallel to the flanges
$z$	Cross-section axis perpendicular to the flanges; lever arm
$z_0$	Vertical distance

*Greek upper case letters*

$\Delta\sigma$	Stress range
$\Delta\sigma_c$	Reference value of the fatigue strength at 2 million cycles
$\Delta\sigma_E$	Equivalent constant amplitude stress range
$\Delta\sigma_{E, glob}$	Equivalent constant amplitude stress range due to global effects
$\Delta\sigma_{E, loc}$	Equivalent constant amplitude stress range due to local effects
$\Delta\sigma_{E, 2}$	Equivalent constant amplitude stress range related to 2 million cycles
$\Delta\sigma_s$	Increase of stress in steel reinforcement due to tension stiffening of concrete
$\Delta\sigma_{s, equ}$	Damage equivalent stress range
$\Delta\tau$	Range of shear stress for fatigue loading
$\Delta\tau_c$	Reference value of the fatigue strength at 2 million cycles
$\Delta\tau_E$	Equivalent constant amplitude stress range
$\Delta\tau_{E, 2}$	Equivalent constant amplitude range of shear stress related to 2 million cycles
$\Delta\tau_R$	Fatigue shear strength
$\Psi$	Coefficient

*Greek lower case letters*

$\alpha$	Factor; parameter, see 6.4.2 (6)
$\alpha_{cr}$	Factor by which the design loads would have to be increased to cause elastic instability
$\alpha_M$	Coefficient related to bending of a composite column
$\alpha_{M, y}, \alpha_{M, z}$	Coefficient related to bending of a composite column about the y-y axis and the z-z axis respectively
$\alpha_{st}$	Ratio
$\beta$	Factor; transformation parameter, Half of the angle of spread of longitudinal shear force $V_c$ into the concrete slab
$\gamma_C$	Partial factor for concrete
$\gamma_F$	Partial factor for actions, also accounting for model uncertainties and dimensional variations
$\gamma_{Ff}$	Partial factor for equivalent constant amplitude stress range
$\gamma_M$	Partial factor for a material property, also accounting for model uncertainties and dimensional variations
$\gamma_{M0}$	Partial factor for structural steel applied to resistance of cross-sections, see EN 1993-1-1: 2005, 6.1(1)
$\gamma_{M1}$	Partial factor for structural steel applied to resistance of members to instability assessed by member checks, see EN 1993-1-1: 2005, 6.1(1)



$\gamma_{Mf}$	Partial factor for fatigue strength
$\gamma_{Mf,s}$	Partial factor for fatigue strength of studs in shear
$\gamma_p$	Partial factor for pre-stressing action
$\gamma_s$	Partial factor for reinforcing steel
$\gamma_v$	Partial factor for design shear resistance of a headed stud
$\delta$	Factor; steel contribution ratio; central deflection
$\delta_{uk}$	Characteristic value of slip capacity
$\varepsilon$	$\sqrt{235 / f_y}$ , where $f_y$ is in N/mm <sup>2</sup>
$\eta_a, \eta_{ao}$	Factors related to the confinement of concrete
$\eta_c, \eta_{co}, \eta_{cL}$	Factors related to the confinement of concrete
$\theta$	Angle
$\lambda, \lambda_v$	Damage equivalent factors
$\lambda_{v,l}$	Factor to be used for the determination of the damage equivalent factor $\lambda_v$ for headed studs in shear
$\lambda_{glob}, \lambda_{loc}$	Damage equivalent factors for global effects and local effects, respectively
$\bar{\lambda}$	Relative slenderness
$\bar{\lambda}_{LT}$	Relative slenderness for lateral-torsional buckling
$\mu$	Coefficient of friction; nominal factor
$\mu_d$	Factor related to design for compression and uniaxial bending
$\mu_{dy}, \mu_{dz}$	Factor $\mu_d$ related to plane of bending
$\nu_a$	Poisson's ratio for structural steel
$\rho$	Parameter related to reduced design bending resistance accounting for vertical shear
$\rho_s$	Parameter; reinforcement ratio
$\sigma_{c,Rd}$	Local design strength of concrete
$\sigma_{ct}$	Extreme fibre tensile stress in the concrete
$\sigma_{max,f}$	Maximum stress due to fatigue loading
$\sigma_{min,f}$	Minimum stress due to fatigue loading
$\sigma_{s,max,f}$	Stress in the reinforcement due to the bending moment $M_{Ed,max,f}$
$\sigma_{s,min,f}$	Stress in the reinforcement due to the bending moment $M_{Ed,min,f}$
$\sigma_s$	Stress in the tension reinforcement
$\sigma_{s,max}$	Stress in the reinforcement due to the bending moment $M_{max}$
$\sigma_{s,max,0}$	Stress in the reinforcement due to the bending moment $M_{max}$ , neglecting concrete in tension
$\sigma_{s,0}$	Stress in the tension reinforcement neglecting tension stiffening of concrete
$\tau_{Rd}$	Design shear strength
$\phi$	Diameter (size) of a steel reinforcing bar; damage equivalent impact factor
$\phi^*$	Diameter (size) of a steel reinforcing bar
$\varphi$	Creep coefficient
$\varphi(t, t_0)$	Creep coefficient, defining creep between times $t$ and $t_0$ , related to elastic deformation at 28 days
$\chi$	Reduction factor for flexural buckling
$\chi_{LT}$	Reduction factor for lateral-torsional buckling
$\psi_L$	Creep multiplier

## Section 2 Basis of design

### 2.1 Requirements

(1)P The design of composite structures shall be in accordance with the general rules given in EN 1990: 2002.

(2)P The supplementary provisions for composite structures given in this Section shall also be applied.

(3) The basic requirements of EN 1990: 2002, Section 2 are deemed to be satisfied for composite structures when the following are applied together:

- limit state design in conjunction with the partial factor method in accordance with EN 1990: 2002,
- actions in accordance with EN 1991,
- combination of actions in accordance with EN 1990: 2002 and
- resistances, durability and serviceability in accordance with this Standard.

### 2.2 Principles of limit states design

(1)P For composite structures, relevant stages in the sequence of construction shall be considered.

### 2.3 Basic variables

#### 2.3.1 Actions and environmental influences

(1) Actions to be used in design may be obtained from the relevant parts of EN 1991.

(2)P In verification for steel sheeting as shuttering, account shall be taken of the ponding effect (increased depth of concrete due to the deflection of the sheeting).

#### 2.3.2 Material and product properties

(1) Unless otherwise given by Eurocode 4, actions caused by time-dependent behaviour of concrete should be obtained from EN 1992-1-1: 2004.

#### 2.3.3 Classification of actions

(1)P The effects of shrinkage and creep of concrete and non-uniform changes of temperature result in internal forces in cross sections, and curvatures and longitudinal strains in members; the effects that occur in statically determinate structures, and in statically indeterminate structures when compatibility of the deformations is not considered, shall be classified as primary effects.

(2)P In statically indeterminate structures the primary effects of shrinkage, creep and temperature are associated with additional action effects, such that the total effects are compatible; these shall be classified as secondary effects and shall be considered as indirect actions.

## 2.4 Verification by the partial factor method

### 2.4.1 Design values

#### 2.4.1.1 Design values of actions

(1) For pre-stress by controlled imposed deformations, e.g. by jacking at supports, the partial safety factor  $\gamma_p$  should be specified for ultimate limit states, taking into account favourable and unfavourable effects.

**NOTE:** Values for  $\gamma_p$  may be given in the National Annex. The recommended value for both favourable and unfavourable effects is 1,0.

#### 2.4.1.2 Design values of material or product properties

(1)P Unless an upper estimate of strength is required, partial factors shall be applied to lower characteristic or nominal strengths.

(2)P For concrete, a partial factor  $\gamma_c$  shall be applied. The design compressive strength shall be given by:

$$f_{cd} = f_{ck} / \gamma_c \quad (2.1)$$

where the characteristic value  $f_{ck}$  shall be obtained by reference to EN 1992-1-1: 2004, 3.1 for normal concrete and to EN 1992-1-1: 2004, 11.3 for lightweight concrete.

**NOTE:** The value for  $\gamma_c$  is that used in EN 1992-1-1: 2004.

(3)P For steel reinforcement, a partial factor  $\gamma_s$  shall be applied.

**NOTE:** The value for  $\gamma_s$  is that used in EN 1992-1-1: 2004.

(4)P For structural steel, steel sheeting and steel connecting devices, partial factors  $\gamma_M$  shall be applied. Unless otherwise stated, the partial factor for structural steel shall be taken as  $\gamma_{M0}$ .

**NOTE:** Values for  $\gamma_M$  are those given in EN 1993-2.

(5)P For shear connection, a partial factor  $\gamma_V$  shall be applied.

**NOTE:** The value for  $\gamma_V$  may be given in the National Annex. The recommended value for  $\gamma_V$  is 1,25.

(6)P For fatigue verification of headed studs in bridges, partial factors  $\gamma_{MF}$  and  $\gamma_{MF,s}$  shall be applied.

**NOTE:** The value for  $\gamma_{MF}$  is that used in EN 1993-2. The value for  $\gamma_{MF,s}$  may be given in the National Annex. The recommended value for  $\gamma_{MF,s}$  is 1,0.

#### 2.4.1.3 Design values of geometrical data

(1) Geometrical data for cross-sections and systems may be taken from product standards hEN or drawings for the execution and treated as nominal values.

#### 2.4.1.4 Design resistances

(1)P For composite structures, design resistances shall be determined in accordance with EN 1990: 2002, expression (6.6a) or expression (6.6c).

### 2.4.2 Combination of actions

- (1) The general formats for combinations of actions are given in EN 1990: 2002, Section 6.
- (2) For bridges the combinations of actions are given in Annex A2 of EN 1990: 2002.

### 2.4.3 Verification of static equilibrium (EQU)

- (1) The reliability format for the verification of static equilibrium for bridges, as described in EN 1990: 2002, Table A2.4(A), also applies to design situations equivalent to (EQU), e.g. for the design of holding down anchors or the verification of uplift of bearings of continuous beams.

## Section 3 Materials

### 3.1 Concrete

- (1) Unless otherwise given by Eurocode 4, properties should be obtained by reference to EN 1992-1-1: 2004, 3.1 for normal concrete and to EN 1992-1-1: 2004, 11.3 for lightweight concrete.
- (2) This Part of EN 1994 does not cover the design of composite structures with concrete strength classes lower than C20/25 and LC20/22 and higher than C60/75 and LC60/66.
- (3) Shrinkage of concrete should be determined taking account of the ambient humidity, the dimensions of the element and the composition of the concrete.

### 3.2 Reinforcing steel for bridges

- (1) Properties should be obtained by reference to EN 1992-1-1: 2004, 3.2, except 3.2.4 where EN 1992-2 applies.
- (2) For composite structures, the design value of the modulus of elasticity  $E_s$  may be taken as equal to the value for structural steel given in EN 1993-1-1: 2005, 3.2.6.
- (3) Ductility characteristics should comply with EN 1992-2, 3.2.4.

### 3.3 Structural steel for bridges

- (1) Properties should be obtained by reference to EN 1993-2.
- (2) The rules in this Part of EN 1994 apply to structural steel of nominal yield strength not more than 460 N/mm<sup>2</sup>.

### 3.4 Connecting devices

#### 3.4.1 General

- (1) Reference should be made to EN 1993-1-8: 2005 for requirements for fasteners and welding consumables.

#### 3.4.2 Headed stud shear connectors

- (1) Reference should be made to EN 13918.

### **3.5 Prestressing steel and devices**

(1) Reference should be made to clauses 3.3 and 3.4 of EN1992-1-1: 2004.

### **3.6 Tension components in steel**

(1) Reference should be made to EN 1993-1-11.

## **Section 4 Durability**

### **4.1 General**

(1) The relevant provisions given in EN 1990, EN 1992 and EN 1993 should be followed.

(2) Detailing of the shear connection should be in accordance with 6.6.5.

### **4.2 Corrosion protection at the steel-concrete interface in bridges**

(1) The corrosion protection of the steel flange should extend into the steel-concrete interface at least 50 mm. For additional rules for bridges with pre-cast deck slabs, see Section 8.

## **Section 5 Structural analysis**

### **5.1 Structural modelling for analysis**

#### **5.1.1 Structural modelling and basic assumptions**

(1)P The structural model and basic assumptions shall be chosen in accordance with EN 1990: 2002, 5.1.1 and shall reflect the anticipated behaviour of the cross-sections, members, joints and bearings.

(2) Section 5 is applicable to composite bridges in which most of the structural members and joints are either composite or of structural steel. Where the structural behaviour is essentially that of a reinforced or pre-stressed concrete structure, with only a few composite members, global analysis should be generally in accordance with EN 1992-2.

(3) Analysis of composite plates should be in accordance with Section 9.

#### **5.1.2 Joint modelling**

(1) The effects of the behaviour of the joints on the distribution of internal forces and moments within a structure, and on the overall deformations of the structure, may generally be neglected, but where such effects are significant (such as in the case of semi-continuous joints) they should be taken into account, see Section 8 and EN 1993-1-8: 2005.

(2) To identify whether the effects of joint behaviour on the analysis need be taken into account, a distinction may be made between three joint models as follows, see 8.2 and EN 1993-1-8: 2005, 5.1.1:

- simple, in which the joint may be assumed not to transmit bending moments;
- continuous, in which the stiffness and/or resistance of the joint allow full continuity of the members to be assumed in the analysis;
- semi-continuous, in which the behaviour of the joint needs to be taken into account in the analysis.

(3) In bridge structures semi-continuous composite joints should not be used.

### 5.1.3 Ground-structure interaction

(1)P Account shall be taken of the deformation characteristics of the supports where significant.

NOTE: EN 1997-1: 2004 gives guidance for calculation of soil-structure interaction.

(2) Where settlements have to be taken into account and where no design values have been specified, appropriate estimated values of predicted settlement should be used.

(3) Effects due to settlements may normally be neglected in ultimate limit states other than fatigue for composite members where all cross sections are in class 1 or 2 and bending resistance is not reduced by lateral torsional buckling.

## 5.2 Structural stability

### 5.2.1 Effects of deformed geometry of the structure

(1) The action effects may generally be determined using either:

- first-order analysis, using the initial geometry of the structure;
- second-order analysis, taking into account the influence of the deformation of the structure.

(2)P The effects of the deformed geometry (second-order effects) shall be considered if they increase the action effects significantly or modify significantly the structural behaviour.

(3) First-order analysis may be used if the increase of the relevant internal forces or moments caused by the deformations given by first-order analysis is less than 10%. This condition may be assumed to be fulfilled if the following criterion is satisfied:

$$\alpha_{cr} \geq 10 \quad (5.1)$$

where:

$\alpha_{cr}$  is the factor by which the design loading would have to be increased to cause elastic instability.

(4)P In determining the stiffness of the structure, appropriate allowances shall be made for cracking and creep of concrete and for the behaviour of the joints.

### 5.2.2 Methods of analysis for bridges

(1) For bridge structures EN 1993-2, 5.2.2 applies.

## 5.3 Imperfections

### 5.3.1 Basis

(1)P Appropriate allowances shall be incorporated in the structural analysis to cover the effects of imperfections, including residual stresses and geometrical imperfections such as lack of verticality, lack of straightness, lack of flatness, lack of fit and the unavoidable minor eccentricities present in joints of the unloaded structure.

(2)P The assumed shape of imperfections shall take account of the elastic buckling mode of the structure or member in the plane of buckling considered, in the most unfavourable direction and form.

### **5.3.2 Imperfections for bridges**

(1) Equivalent geometric imperfections should be used with values that reflect the possible effects of system imperfections and also member imperfections unless these effects are included in the resistance formulae.

(2) The imperfections and design transverse forces for stabilising transverse frames should be calculated in accordance with EN 1993-2, 5.3 and 6.3.4.2, respectively.

(3) For composite columns and composite compression members, member imperfections should always be considered when verifying stability within a member's length in accordance with 6.7.3.6 or 6.7.3.7. Design values of equivalent initial bow imperfection should be taken from Table 6.5.

(4) Imperfections within steel compression members should be considered in accordance with EN 1993-2, 5.3.

## **5.4 Calculation of action effects**

### **5.4.1 Methods of global analysis**

#### **5.4.1.1 General**

(1) Action effects may be calculated by elastic global analysis, even where the resistance of a cross-section is based on its plastic or non-linear resistance.

(2) Elastic global analysis should be used for serviceability limit states, with appropriate corrections for non-linear effects such as cracking of concrete.

(3) Elastic global analysis should be used for verifications of the limit state of fatigue.

(4)P The effects of shear lag and of local buckling shall be taken into account if these significantly influence the global analysis.

(5) The effects of local buckling of steel elements on the choice of method of analysis may be taken into account by classifying cross-sections, see 5.5.

(6) The effects of local buckling of steel elements on stiffness may be ignored in normal composite sections. For cross-sections of Class 4, see EN 1993-1-5, 2.2.

(7) The effects on the global analysis of slip in bolt holes and similar deformations of connecting devices should be considered.

(8) Unless non-linear analysis is used, the effects of slip and separation on calculation of internal forces and moments may be neglected at interfaces between steel and concrete where shear connection is provided in accordance with 6.6.

(9) For transient design situations during erection stages uncracked global analysis and the distribution of effective width according to 5.4.1.2(4) may be used.



#### 5.4.1.2 Effective width of flanges for shear lag

(1)P Allowance shall be made for the flexibility of steel or concrete flanges affected by shear in their plane (shear lag) either by means of rigorous analysis, or by using an effective width of flange.

(2) The effects of shear lag in steel plate elements should be considered in accordance with EN 1993-1-1: 2005, 5.2.1(5).

(3) The effective width of concrete flanges should be determined in accordance with the following provisions.

(4) When elastic global analysis is used, a constant effective width may be assumed over the whole of each span. This value may be taken as the value  $b_{\text{eff},1}$  at mid-span for a span supported at both ends, or the value  $b_{\text{eff},2}$  at the support for a cantilever.

(5) At mid-span or an internal support, the total effective width  $b_{\text{eff}}$ , see Figure 5.1, may be determined as:

$$b_{\text{eff}} = b_0 + \sum b_{\text{ci}} \quad (5.3)$$

where:

$b_0$  is the distance between the centres of the outstand shear connectors;

$b_{\text{ci}}$  is the value of the effective width of the concrete flange on each side of the web and taken as  $L_c/8$  ( but not greater than the geometric width  $b_i$  . The value  $b_i$  should be taken as the distance from the outstand shear connector to a point mid-way between adjacent webs, measured at mid-depth of the concrete flange, except that at a free edge  $b_i$  is the distance to the free edge. The length  $L_c$  should be taken as the approximate distance between points of zero bending moment. For typical continuous composite beams, where a moment envelope from various load arrangements governs the design, and for cantilevers,  $L_c$  may be assumed to be as shown in Figure 5.1.

(6) The effective width at an end support may be determined as:

$$b_{\text{eff}} = b_0 + \sum \beta_i b_{\text{ci}} \quad (5.4)$$

with:

$$\beta_i = (0,55 + 0,025 L_c / b_{\text{ci}}) \leq 1,0 \quad (5.5)$$

where:

$b_{\text{ci}}$  is the effective width, see (5), of the end span at mid-span and  $L_c$  is the equivalent span of the end span according to Figure 5.1.

(7) The distribution of the effective width between supports and midspan regions may be assumed to be as shown in Figure 5.1.

(8) The transverse distribution of stresses due to shear lag may be taken in accordance with EN 1993-1-5, 3.2.2 for both concrete and steel flanges.

(9) For cross-sections with bending moments resulting from the main-girder system and from a local system (for example in composite trusses with direct actions on the chord between nodes) the relevant effective widths for the main girder system and the local system should be used for the relevant bending moments.

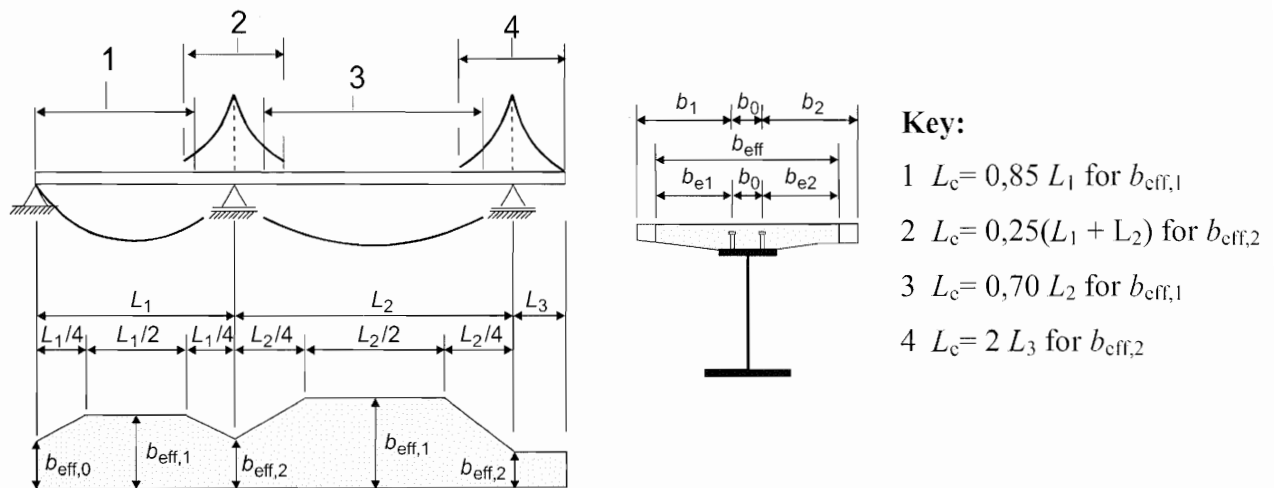

Figure 5.1: Equivalent spans, for effective width of concrete flange

## 5.4.2 Linear elastic analysis

### 5.4.2.1 General

(1) Allowance should be made for the effects of cracking of concrete, creep and shrinkage of concrete, sequence of construction and pre-stressing.

### 5.4.2.2 Creep and shrinkage

(1)P Appropriate allowance shall be made for the effects of creep and shrinkage of concrete.

(2) Except for members with both flanges composite, the effects of creep may be taken into account by using modular ratios  $n_L$  for the concrete. The modular ratios depending on the type of loading (subscript L) are given by:

$$n_L = n_0 (1 + \psi_L \varphi_t) \quad (5.6)$$

where:

$n_0$  is the modular ratio  $E_a / E_{cm}$  for short-term loading;

$E_{cm}$  is the secant modulus of elasticity of the concrete for short-term loading according to EN 1992-1-1: 2004, Table 3.1 or Table 11.3.1;

$\varphi_t$  is the creep coefficient  $\varphi(t, t_0)$  according to EN 1992-1-1: 2004, 3.1.4 or 11.3.3, depending on the age ( $t$ ) of concrete at the moment considered and the age ( $t_0$ ) at loading;

$\psi_L$  is the creep multiplier depending on the type of loading, which  $\overline{AC1}$  should  $\overline{AC1}$  be taken as 1.1 for permanent loads, 0.55 for primary and secondary effects of shrinkage and 1.5 for pre-stressing by imposed deformations.

(3) For permanent loads on composite structures cast in several stages one mean value  $t_0$  may be used for the determination of the creep coefficient. This assumption may also be used for pre-stressing by imposed deformations, if the age of all of the concrete in the relevant spans at the time of pre-stressing is more than 14 days.

- (4) For shrinkage, the age at loading should generally be assumed to be one day.
- (5) Where prefabricated slabs are used or when pre-stressing of the concrete slab is carried out before the shear connection has become effective, the creep coefficient and the shrinkage values from the time when the composite action becomes effective should be used.
- (6) Where in bridges the bending moment distribution at  $t_0$  is significantly changed by creep, for example in continuous beams of mixed structures with both composite and non-composite spans, the time-dependent secondary effects due to creep should be considered, except in global analysis for the ultimate limit state for members where all cross-sections are in Class 1 or 2 and in which no allowance for lateral torsional buckling is necessary. For the time-dependent secondary effects the modular ratio may be determined with a creep multiplier  $\psi_L$  of 0.55.
- (7) Appropriate account should be taken of the primary and secondary effects caused by shrinkage and creep of the concrete flange. The effects of creep and shrinkage of concrete may be neglected in analysis for verifications of ultimate limit states other than fatigue, for composite members with all cross-sections in Class 1 or 2 and in which no allowance for lateral-torsional buckling is necessary; for serviceability limit states, see Section 7.
- (8) In regions where the concrete slab is assumed to be cracked, the primary effects due to shrinkage may be neglected in the calculation of secondary effects.
- (9) In composite columns and compression members, account should be taken of the effects of creep in accordance with 6.7.3.4(2).
- (10) For double composite action with both flanges un-cracked (e.g. in case of pre-stressing) the effects of creep and shrinkage should be determined by more accurate methods.
- (11) The St. Venant torsional stiffness of box girders should be calculated for a transformed cross section in which the concrete slab thickness is reduced by the modular ratio  $n_{0G} = G_a/G_c$  where  $G_a$  and  $G_c$  are the elastic shear moduli of structural steel and concrete respectively. The effects of creep should be taken into account in accordance with (2) with the modular ratio  $n_{LG} = n_{0G} (1 + \psi_L \phi_t)$ .

#### 5.4.2.3 Effects of cracking of concrete

- (1)P Appropriate allowance shall be made for the effects of cracking of concrete.
- (2) The following method may be used for the determination of the effects of cracking in composite beams with concrete flanges. First the envelope of the internal forces and moments for the characteristic combinations, see EN 1990; 2002, 6.5.3, including long-term effects should be calculated using the flexural stiffness  $E_a I_1$  of the un-cracked sections. This is defined as “un-cracked analysis”.
- In regions where the extreme fibre tensile stress in the concrete due to the envelope of global effects exceeds twice the strength  $f_{ctm}$  or  $f_{ctm}$ , see EN1992-1-1: 2004, Table 3.1 or Table 11.3.1, the stiffness should be reduced to  $E_a I_2$ , see 1.5.2.12. This distribution of stiffness may be used for ultimate limit states and for serviceability limit states. A new distribution of internal forces and moments, and deformation if appropriate, is then determined by re-analysis. This is defined as “cracked analysis”.

- (3) For continuous composite beams with the concrete flanges above the steel section and not prestressed, including beams in frames that resist horizontal forces by bracing, the following simplified method may be used. Where all the ratios of the length of adjacent continuous spans (shorter / longer) between supports are at least 0.6, the effect of cracking may be taken into account by using the flexural stiffness  $E_a I_2$  over 15% of the span on each side of each internal support, and as the uncracked values  $E_a I_1$  elsewhere.
- (4) The effect of cracking of concrete on the flexural stiffness of composite columns and compression members should be determined in accordance with 6.7.3.4.
- (5) Unless a more precise method is used, in multiple beam decks where transverse composite members are not subjected to tensile forces, it may be assumed that the transverse members are uncracked throughout.
- (6) The torsional stiffness of box girders should be calculated for a transformed cross section. In areas where the concrete slab is assumed to be cracked due to bending, the calculation should be performed considering a slab thickness reduced to one half, unless the effect of cracking is considered in a more precise way.
- (7) For ultimate limit states the effects of cracking on the longitudinal shear forces at the interface between the steel and concrete section should be taken into account according to 6.6.2.
- (8) For serviceability limit states the longitudinal shear forces at the interface between the steel and concrete section should be calculated by uncracked analysis. If alternatively the effects of cracking are taken into account, tension stiffening and over-strength of concrete in tension should be considered.

#### **5.4.2.4 Stages and sequence of construction**

- (1)P Appropriate analysis shall be made to cover the effects of staged construction including where necessary separate effects of actions applied to structural steel and to wholly or partially composite members.
- (2) The effects of sequence of construction may be neglected in analysis for ultimate limit states other than fatigue, for composite members where all cross-sections are in Class 1 or 2 and in which no allowance for lateral-torsional buckling is necessary.

#### **5.4.2.5 Temperature effects**

- (1) Account should be taken of effects due to temperature in accordance with EN 1991-1-5.
- (2) Temperature effects may normally be neglected in analysis for the ultimate limit states other than fatigue, for composite members where all cross-sections are in Class 1 or Class 2 and in which no allowance for lateral-torsional buckling is necessary.
- (3) For simplification in global analysis and for the determination of stresses for composite structures, the value of the coefficient of linear thermal expansion for structural steel may be taken as  $10 \times 10^{-6}$  per °C. For calculation of change in length of the bridge, the coefficient of thermal expansion should be taken as  $12 \times 10^{-6}$  per °C for all structural materials.

#### 5.4.2.6 Pre-stressing by controlled imposed deformations

(1)P Where pre-stressing by controlled imposed deformations (e.g. jacking of supports) is provided, the effects of possible deviations from the assumed values of imposed deformations and stiffness on the internal moments and forces shall be considered for analysis of ultimate and serviceability limit states.

(2) Unless a more accurate method is used to determine internal moments and forces, the characteristic values of indirect actions due to imposed deformations may be calculated with the characteristic or nominal values of properties of materials and of imposed deformation, if the imposed deformations are controlled.

#### 5.4.2.7 Pre-stressing by tendons

(1) Internal forces and moments due to pre-stressing by bonded tendons should be determined in accordance with EN 1992-1-1: 2004, 5.10.2 taking into account the effects of creep and shrinkage of concrete and cracking of concrete where relevant.

(2) In global analysis, forces in unbonded tendons should be treated as external forces. For the determination of forces in permanently unbonded tendons, deformations of the whole structure should be taken into account.

#### 5.4.2.8 Tension members in composite bridges

(1) In this clause, *concrete tension member* means either:

- (a) an isolated reinforced concrete tension member acting together with a tension member of structural steel, with shear connection only at the ends of the member, which causes a global tensile force in the concrete tension member; or
- (b) the reinforced concrete part of a composite member with shear connection over the member length (*a composite tension member*) subjected to longitudinal tension.

Typical examples occur in bowstring arches and trusses where the concrete or composite members act as tension members in the main composite system.

(2)P For the determination of the internal forces and moments in a tension member, the non-linear behaviour due to cracking of concrete and the effects of tension stiffening of concrete shall be considered for the global analyses for ultimate and serviceability limit states and for the limit state of fatigue. Account shall be taken of effects resulting from over-strength of concrete in tension.

(3) For the calculation of the internal forces and moments of a cracked *concrete tension member* the effects of shrinkage of concrete between cracks should be taken into account. The effects of autogenous shrinkage may be neglected. For simplification and where (6) or (7) is used, the free shrinkage strain of the uncracked member should be used for the determination of secondary effects due to shrinkage.

(4) Unless a more accurate method according to (2) and (3) is used, the simplified method according to (5) may be used. Alternatively, the methods of (6) and (7) are applicable.

(5) The effects of tension stiffening of concrete may be neglected, if in the global analysis the internal forces and moments of the *concrete tension member* are determined by uncracked analysis and the internal forces of structural steel members are determined by cracked analysis.

(6) The internal forces and moments in bowstring arches with isolated reinforced *concrete tension members* with shear connection only at the ends of the member may be determined as follows:

- determination of the internal forces of the steel structure with an effective longitudinal stiffness  $(EA_s)_{\text{eff}}$  of the cracked concrete tension member according to equation (5.6-1).

$$(EA_s)_{\text{eff}} = \frac{E_s A_s}{1 - 0.35 / (1 + n_o \rho_s)} \quad (5.6-1)$$

where  $n_o$  is the modular ratio for short term loading according to 5.4.2.2(2),  $A_s$  is the longitudinal reinforcement of the concrete tension member within the effective width and  $\rho_s$  is the reinforcement ratio  $\rho_s = A_s / A_c$  determined with the effective concrete cross-section area  $A_c$ ,

- the normal forces of the concrete tension member  $N_{\text{Ed, serv}}$  for the serviceability limit state and  $N_{\text{Ed, ult}}$  for the ultimate limit state are given by

$$N_{\text{Ed, serv.}} = 1.15 A_c f_{\text{ct, eff}} (1 + n_o \rho_s) \quad (5.6-2)$$

$$N_{\text{Ed, ult.}} = 1.45 A_c f_{\text{ct, eff}} (1 + n_o \rho_s) \quad (5.6-3)$$

where  $f_{\text{ct, eff}}$  is the effective tensile strength of concrete.

Unless verified by more accurate methods, the effective tensile strength may be assumed as  $f_{\text{ct, eff}} = 0,7 f_{\text{ctm}}$  where the *concrete tension member* is simultaneously acting as a deck and is subjected to combined global and local effects.

(7) For *composite tension members* subjected to normal forces and bending moments, the cross-section properties of the cracked section and the normal force of the reinforced concrete part of the composite member should be determined with the effective longitudinal stiffness of the reinforcement according to equation (5.6-1). If the normal forces of the reinforced concrete part of the member do not exceed the values given by the equations (5.6-2) and (5.6-3), these values should be used for design. Stresses in reinforcement should be determined with these forces but taking into account the actual cross-section area  $A_s$  of reinforcement.

#### 5.4.2.9 Filler beam decks for bridges

(1) Where the detailing is in accordance with 6.3, in longitudinal bending the effects of slip between the concrete and the steel beams and effects of shear lag may be neglected. The contribution of formwork supported from the steel beams, which becomes part of the permanent construction, should be neglected.

(2) Where the distribution of loads applied after hardening of concrete is not uniform in the direction transverse to the span of the filler beams, the analysis should take account of the transverse distribution of forces due to the difference between the deformation of adjacent filler beams and of the flexural stiffness transverse to the filler beam, unless it is verified that sufficient accuracy is obtained by a simplified analysis assuming rigid behaviour in the transverse direction.

(3) Account may be taken of the effects described in (2) by using one of the following methods of analysis:

- modelling by an orthotropic slab by smearing of the steel beams;
- considering the concrete as discontinuous so as to have a plane grid with members having flexural and torsional stiffness where the torsional stiffness of the steel section may be neglected. For the determination of internal forces in the transverse direction, the flexural

and torsional stiffness of the transverse concrete members may be assumed to be 50 % of the uncracked stiffness,

- general methods according to 5.4.3.

The nominal value of Poisson's ratio of concrete may be assumed to be zero for ultimate limit states and 0.2 for serviceability limit states.

(4) Internal forces and moments should be determined by elastic analysis, neglecting redistribution of moments and internal forces due to cracking of concrete.

(5) Hogging bending moments of continuous filler beams with Class 1 cross-sections at internal supports may be redistributed for ultimate limit states other than fatigue by amounts not exceeding 15% to take into account inelastic behaviour of materials. For each load case the internal forces and moments after redistribution should be in equilibrium with the loads.

(6) Effects of creep on deformations may be taken into account according to 5.4.2.2. The effects of shrinkage of concrete may be neglected.

(7) For the determination of deflections and precamber for the serviceability limit state as well as for dynamic analysis the effective flexural stiffness of filler beam decks may be taken as

$$E_a I_{\text{eff}} = 0.5 (E_a I_1 + E_a I_2) \quad (5.6-4)$$

where  $I_1$  and  $I_2$  are the uncracked and the cracked values of second moment of area of the composite cross- subjected to sagging bending as defined in 1.5.2.11 and 1.5.2.12. The second moment of area  $I_2$  should be determined with the effective cross-section of structural steel, reinforcement and concrete in compression. The area of concrete in compression may be determined from the plastic stress distribution.

(8) The influences of differences and gradients of temperature may be ignored, except for the determination of deflections of railway bridges without ballast bed or railway bridges with non ballasted slab track.

### 5.4.3 Non-linear global analysis for bridges

(1)P Non-linear analysis may be used. No application rules are given.

(2)P The behaviour of the shear connection shall be taken into account.

(3)P Effects of the deformed geometry of the structure shall be taken into account.

### 5.4.4 Combination of global and local action effects

(1) Global and local action effects should be added taking into account a combination factor.

**NOTE:** The combination factor may be given in the National Annex. Relevant information for road bridges is given in Annex E of EN 1993-2.

## 5.5 Classification of cross-sections

### 5.5.1 General

(1)P The classification system defined in EN 1993-1-1: 2005, 5.5.2 applies to cross-sections of composite beams.



(2) A composite section should be classified according to the least favourable class of its steel elements in compression. The class of a composite section normally depends on the direction of the bending moment at that section.

(3) A steel compression element restrained by attaching it to a reinforced concrete element may be placed in a more favourable class, provided that the resulting improvement in performance has been established.

(4) For classification, the plastic stress distribution should be used except at the boundary between Classes 3 and 4, where the elastic stress distribution should be used taking into account sequence of construction and the effects of creep and shrinkage. For classification, design values of strengths of materials should be used. Concrete in tension should be neglected. The distribution of the stresses should be determined for the gross cross-section of the steel web and the effective flanges.

(5) For cross-sections in Class 1 and 2 with bars in tension, reinforcement used within the effective width should have a ductility Class B or C, see EN 1992-1-1: 2004, Table C.1. Additionally for a section whose resistance moment is determined by 6.2.1.2, 6.2.1.3 or 6.2.1.4, a minimum area of reinforcement  $A_s$  within the effective width of the concrete flange should be provided to satisfy the following condition:

$$A_s \geq \rho_s A_c \quad (5.7)$$

with

$$\rho_s = \delta \frac{f_y}{235} \frac{f_{ctm}}{f_{sk}} \sqrt{k_c} \quad (5.8)$$

where:

$A_c$  is the effective area of the concrete flange;

$f_y$  is the nominal value of the yield strength of the structural steel in N/mm<sup>2</sup>;

$f_{sk}$  is the characteristic yield strength of the reinforcement;

$f_{ctm}$  is the mean tensile strength of the concrete, see EN1992-1-1: 2004, Table 3.1 or Table 11.3.1;

$k_c$  is a coefficient given in 7.4.2;

$\delta$  is equal to 1.0 for Class 2 cross-sections, and equal to 1.1 for Class 1 cross-sections at which plastic hinge rotation is required.

(6) Welded mesh should not be included in the effective section unless it has been shown to have sufficient ductility, when built into a concrete slab, to ensure that it will not fracture.

(7) In global analysis for stages in construction, account should be taken of the class of the steel section at the stage considered.

### 5.5.2 Classification of composite sections without concrete encasement

(1) A steel compression flange that is restrained from buckling by effective attachment to a concrete flange by shear connectors may be assumed to be in Class 1 if the spacing of connectors is in accordance with 6.6.5.5.

(2) The classification of other steel flanges and webs in compression in composite beams without concrete encasement should be in accordance with EN 1993-1-1: 2005, Table 5.2. An element that fails to satisfy the limits for Class 3 should be taken as Class 4.

(3) Cross-sections with webs in Class 3 and flanges in Classes 1 or 2 may be treated as an effective cross-section in Class 2 with an effective web in accordance with EN1993-1-1: 2005, 6.2.2.4.

### 5.5.3 Classification of sections of filler beam decks for bridges

(1) A steel outstand flange of a composite section should be classified in accordance with table 5.2.

(2) A web in Class 3 that is encased in concrete may be represented by an effective web of the same cross-section in Class 2.

**Table 5.2: Maximum values  $c/t$  for steel flanges of filler beams**

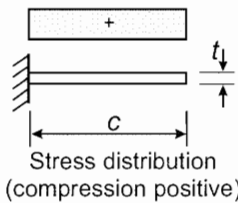
rolled section		welded section		
Class	Type	Limit max ( $c/t$ )		
1	Rrolled or welded	$c/t \leq 9\varepsilon$		$\varepsilon = \sqrt{\frac{235}{f_y}}$ with $f_y$ in $\text{N/mm}^2$
2		$c/t \leq 14\varepsilon$		
3		$c/t \leq 20\varepsilon$		

## Section 6 Ultimate limit states

### 6.1 Beams

#### 6.1.1 Beams in bridges - general

(1) Composite beams should be checked for:

- resistance of cross-sections (see 6.2 and 6.3)
- resistance to lateral-torsional buckling (see 6.4)
- resistance to shear buckling and in-plane forces applied to webs (see 6.2.2 and 6.5)
- resistance to longitudinal shear (see 6.6)
- resistance to fatigue (see 6.8).

#### 6.1.2 Effective width for verification of cross-sections

(1) The effective width of the concrete flange for verification of cross-sections should be determined in accordance with 5.4.1.2 taking into account the distribution of effective width between supports and mid-span regions.

## 6.2 Resistances of cross-sections of beams

### 6.2.1 Bending resistance

#### 6.2.1.1 General

(1)P The design bending resistance shall be determined by rigid-plastic theory only where the effective composite cross-section is in Class 1 or Class 2 and where pre-stressing by tendons is not used.

(2) Elastic analysis and non-linear theory for bending resistance may be applied to cross-sections of any class.

(3) For elastic analysis and non-linear theory it may be assumed that the composite cross-section remains plane if the shear connection and the transverse reinforcement are designed in accordance with 6.6, considering appropriate distributions of design longitudinal shear force.

(4)P The tensile strength of concrete shall be neglected.

(5) Where the steel section of a composite member is curved in plan, the effects of curvature should be taken into account.

### 6.2.1.2 Plastic resistance moment $M_{pl,Rd}$ of a composite cross-section

(1) The following assumptions should be made in the calculation of  $M_{pl,Rd}$ :

- a) there is full interaction between structural steel, reinforcement, and concrete;
- b) the effective area of the structural steel member is stressed to its design yield strength  $f_{yd}$  in tension or compression;
- c) the effective areas of longitudinal reinforcement in tension and in compression are stressed to their design yield strength  $f_{sd}$  in tension or compression. Alternatively, reinforcement in compression in a concrete slab may be neglected;
- d) the effective area of concrete in compression resists a stress of  $0.85 f_{cd}$ , constant over the whole depth between the plastic neutral axis and the most compressed fibre of the concrete, where  $f_{cd}$  is the design cylinder compressive strength of concrete.

Typical plastic stress distributions are shown in Figure 6.2.

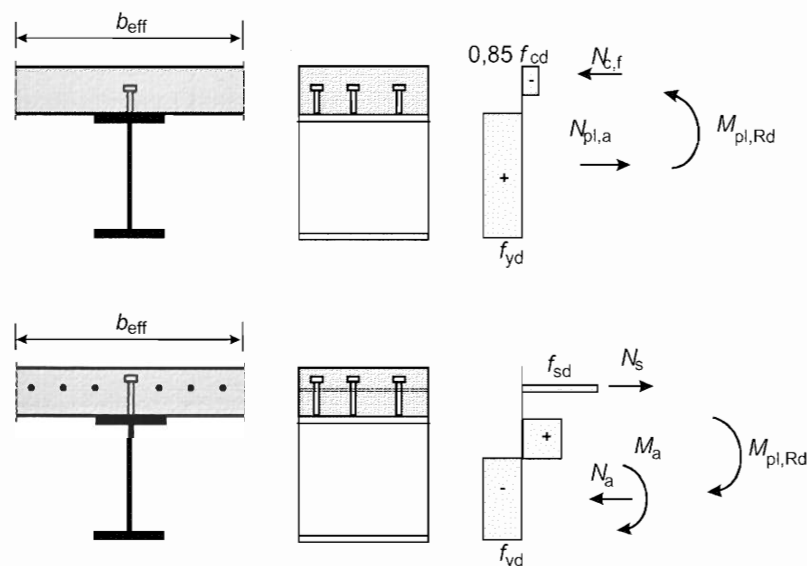

Figure 6.2: Examples of plastic stress distributions for a composite beam with a solid slab and full shear connection in sagging and hogging bending

(2) For composite cross-sections with structural steel grade S420 or S460, where the distance  $x_{pl}$  between the plastic neutral axis and the extreme fibre of the concrete slab in compression exceeds 15% of the overall depth  $h$  of the member, the design resistance moment  $M_{Rd}$  should be taken as  $\beta M_{pl,Rd}$  where  $\beta$  is the reduction factor given in Figure 6.3. For values of  $x_{pl}/h$  greater than 0.4 the resistance to bending should be determined from 6.2.1.4 or 6.2.1.5.

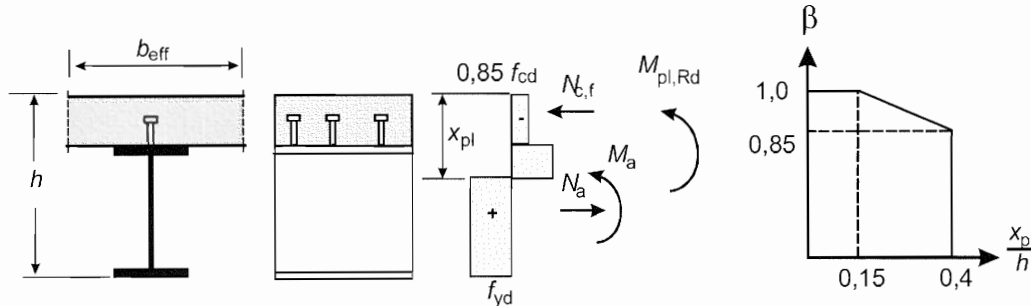

Figure 6.3: Reduction factor  $\beta$  for  $M_{pl,Rd}$

(3) Where plastic theory is used and reinforcement is in tension, that reinforcement should be in accordance with 5.5.1(5).

### 6.2.1.3 Additional rules for beams in bridges

(1) Where a composite beam is subjected to biaxial bending, combined bending and torsion, or combined global and local effects, account should be taken of EN 1993-1-1: 2005, 6.2.1(5).

(2) Where elastic global analysis is used for a continuous beam,  $M_{Ed}$  should not exceed  $0.9 M_{pl,Rd}$  at any cross-section in Class 1 or 2 in sagging bending with the concrete slab in compression where both:

- the cross-section in hogging bending at or near an adjacent support is in Class 3 or 4, and
- the ratio of lengths of the spans adjacent to that support (shorter/longer) is less than 0.6.

Alternatively, a global analysis that takes account of inelastic behaviour should be used.

### 6.2.1.4 Non-linear resistance to bending

(1)P Where the bending resistance of a composite cross-section is determined by non-linear theory, the stress-strain relationships of the materials shall be taken into account.

(2) It should be assumed that the composite cross-section remains plane and that the strain in bonded reinforcement, whether in tension or compression, is the same as the mean strain in the surrounding concrete.

(3) The stresses in the concrete in compression should be derived from the stress-strain curves given in EN 1992-1-1: 2004, 3.1.7.

(4) The stresses in the reinforcement should be derived from the bi-linear diagrams given in EN 1992-1-1: 2004, 3.2.7.

(5) The stresses in structural steel in compression or tension should be derived from the bi-linear diagram given in EN 1993-1-1: 2005, 5.4.3(4) and should take account of the effects of the method of construction (e.g. propped or un-propped).

(6) For Class 1 and Class 2 composite cross-sections with the concrete flange in compression, the non-linear resistance to bending  $M_{Rd}$  may be determined as a function of the compressive force in the concrete  $N_c$  using the simplified expressions (6.2) and (6.3), as shown in Figure 6.6:

$$M_{Rd} = M_{a,Ed} + (M_{cl,Rd} - M_{a,Ed}) \frac{N_c}{N_{c,el}} \quad \text{for } N_c \leq N_{c,el} \quad (6.2)$$

$$M_{Rd} = M_{cl,Rd} + (M_{pl,Rd} - M_{cl,Rd}) \frac{N_c - N_{c,el}}{N_{c,f} - N_{c,el}} \quad \text{for } N_{c,el} \leq N_c \leq N_{c,f} \quad (6.3)$$

with:

$$M_{cl,Rd} = M_{a,Ed} + k M_{c,Ed} \quad (6.4)$$

where:

- $M_{a,Ed}$  is the design bending moment applied to structural steel section before composite behaviour;
- $M_{c,Ed}$  is the part of the design bending moment acting on the composite section;
- $k$  is the lowest factor such that a stress limit in 6.2.1.5(2) is reached; where un-propped construction is used, the sequence of construction should be taken into account;
- $N_{c,el}$  is the compressive force in the concrete flange corresponding to moment  $M_{cl,Rd}$ .

For cross sections where 6.2.1.2 (2) applies, in expression (6.3) and in Figure 6.6 instead of  $M_{pl,Rd}$  the reduced value  $\beta M_{pl,Rd}$  should be used.

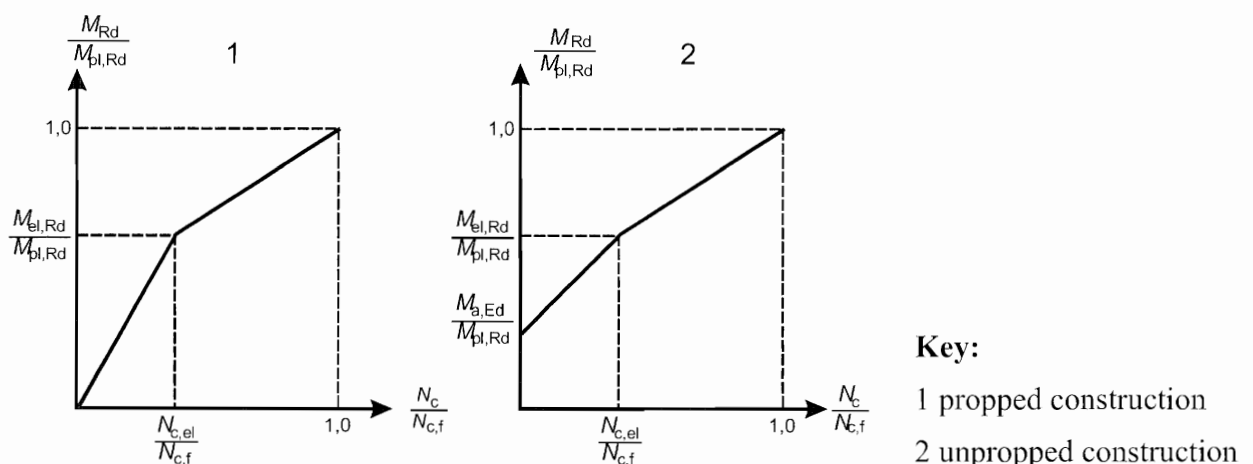

**Figure 6.6: Simplified relationship between  $M_{Rd}$  and  $N_c$  for sections with the concrete slab in compression**

(7) Where the bending resistance of a composite cross-section is determined by non-linear theory, the stresses in prestressing steel should be derived from the design curves in of EN 1992-1-1: 2004, 3.3.6. The design initial pre-strain in prestressing tendons should be taken into account when assessing the stresses in the tendons.

### 6.2.1.5 Elastic resistance to bending

(1) Stresses should be calculated by elastic theory, using an effective width of the concrete flange in accordance with 6.1.2. For cross-sections in Class 4, the effective structural steel section should be determined in accordance with EN 1993-1-5, 4.3.

(2) In the calculation of the elastic resistance to bending based on the effective cross-section, the limiting stresses should be taken as:

- $f_{cd}$  in concrete in compression;
- $f_{yd}$  in structural steel in tension or compression;
- $f_{sd}$  in reinforcement in tension or compression. Alternatively, reinforcement in compression in a concrete slab may be neglected.

(3)P Stresses due to actions on the structural steelwork alone shall be added to stresses due to actions on the composite member.

(4) Unless a more precise method is used, the effect of creep should be taken into account by use of a modular ratio according to 5.4.2.2.

(5) In cross-sections with concrete in tension and assumed to be cracked, the stresses due to primary (isostatic) effects of shrinkage may be neglected.

(6) Compression flanges should be checked for lateral torsional buckling in accordance with 6.4.

(7) For composite bridges with cross-sections in Class 4 designed according to EN 1993-1-5, Section 4, the sum of stresses from different stages of construction and use, calculated on gross sections, should be used for calculating the effective steel cross-section at the time considered. These effective cross-sections should be used for checking stresses in the composite section at the different stages of construction and use.

(8) In the calculation of the elastic resistance to bending based on the effective cross-section, the limiting stress in prestressing tendons should be taken as  $f_{pd}$  according to EN 1992-1-1: 2004, 3.3.6. The stress due to initial prestrain in prestressing tendons should be taken into account in accordance with of EN 1992-1-1: 2004, 5.10.8.

(9) As an alternative to (7) and (8), Section 10 of EN 1993-1-5 may be used.

**NOTE:** The National Annex may give a choice of the methods given in (7) and (8) and Section 10 of EN 1993-1-5.

## 6.2.2 Resistance to vertical shear

### 6.2.2.1 Scope

(1) Clause 6.2.2 applies to composite beams with a rolled or welded structural steel section with a solid web, which may be stiffened.

### 6.2.2.2 Plastic resistance to vertical shear

(1) The resistance to vertical shear  $V_{pl,Rd}$  should be taken as the resistance of the structural steel section  $V_{pl,a,Rd}$  unless the value for a contribution from the reinforced concrete part of the beam has been established.

(2) The design plastic shear resistance  $V_{pl,a,Rd}$  of the structural steel section should be determined in accordance with EN 1993-1-1: 2005, 6.2.6.

### 6.2.2.3 Shear buckling resistance

(1) The shear buckling resistance  $V_{b,Rd}$  of an uncased steel web should be determined in accordance with EN 1993-1-5, 5.

(2) No account should be taken of a contribution from the concrete slab, unless a more precise method than the one of EN 1993-1-5, 5 is used and unless the shear connection is designed for the relevant vertical force.

### 6.2.2.4 Bending and vertical shear

(1) Where the vertical shear force  $V_{Ed}$  exceeds half the shear resistance  $V_{Rd}$  given by  $V_{pl,Rd}$  in 6.2.2.2 or  $V_{b,Rd}$  in 6.2.2.3, whichever is the smaller, allowance should be made for its effect on the resistance moment.

(2) For cross-sections in Class 1 or 2, the influence of the vertical shear on the resistance to bending may be taken into account by a reduced design steel strength  $(1 - \rho)f_{yd}$  in the shear area as shown in Figure 6.7 where:

$$\rho = (2V_{Ed}/V_{Rd} - 1)^2 \quad (6.5)$$

and  $V_{Rd}$  is the appropriate resistance to vertical shear, determined in accordance with 6.2.2.2 or 6.2.2.3.

**AC1** (3) For cross-sections in Classes 3 and 4, EN 1993-1-5:2006, 7.1 is applicable using as  $M_{Ed}$  the total bending moment in the considered cross section and both  $M_{pl,Rd}$  and  $M_{f,Rd}$  for the composite cross section. **AC1**

(4) No account should be taken of the change in the position of the plastic neutral axis of the cross-section caused by the reduced yield strength according to (2) when classifying the web in accordance with 5.5.

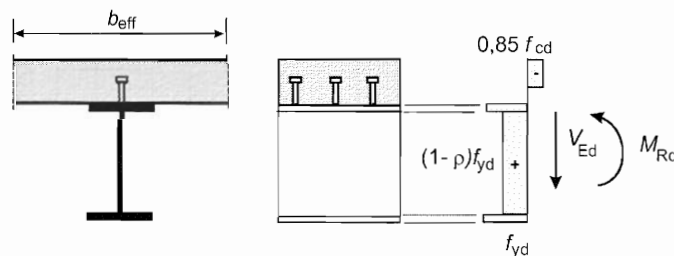

Figure 6.7: Plastic stress distribution modified by the effect of vertical shear

### 6.2.2.5 Additional rules for beams in bridges

(1) When applying EN 1993-1-5, 5.4(1) for a beam with one flange composite, the dimension of the non-composite flange may be used even if that is the larger steel flange. The axial normal force  $N_{Ed}$  in EN 1993-1-5, 5.4(2) should be taken as the axial force acting on the composite section. For composite flanges the effective area should be used.

(2) For the calculation of  $M_{f,Rd}$  in EN 1993-1-5, 7.1(1) the design plastic resistance to bending of the effective composite section excluding the steel web should be used.

(3) For vertical shear in a concrete flange of a composite member, EN 1992-2, 6.2.2 applies.

**NOTE:** For concrete flanges in tension the values of  $C_{Rd,c}$  and  $k_1$  in EN 1992-1-1: 2004, 6.2.2, equations (6.2a and 6.2b) may be given in the National Annex. The value for  $k_1$  should take into account specific aspects of composite action. The recommended values are  $C_{Rd,c} = 0,15/\gamma_C$  and  $k_1 = 0,12$ . AC1 Also where the stress  $\sigma_{cp}$  is tensile (that is,  $\sigma_{cp} < 0$ ) and  $\sigma_{cp} > \sigma_{cp,0}$ , then  $\sigma_{cp}$  should be replaced by  $\sigma_{cp,0}$  in Equations (6.2a) and (6.2b) of EN 1992-1-1:2004, 6.2.2, with the recommended value  $\sigma_{cp,0} = -1,85 \text{ N/mm}^2$ . AC1

## 6.3 Filler beam decks

### 6.3.1 Scope

(1) Clauses 6.3.1 to 6.3.5 are applicable to decks defined in 1.5.2.14. A typical cross-section of a filler beam deck with non-participating permanent formwork is shown in Figure 6.8. No application rules are given for fully encased beams.

**NOTE:** The National Annex may give a reference to rules for transverse filler beams

(2) Steel beams may be rolled sections, or welded sections with a uniform cross-section. For welded sections, both the width of the flanges and the depth of the web should be within the ranges that are available for rolled H- or I- sections.

(3) Spans may be simply supported or continuous. Supports may be square or skew.

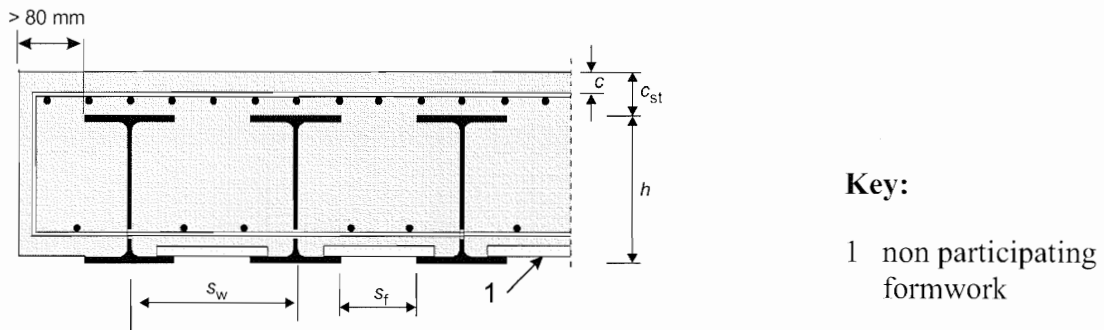

**Figure 6.8: Typical cross-section of a filler beam deck**

(4) Filler-beam decks should comply with the following:

- the steel beams are not curved in plan;
- the skew angle  $\theta$  should not be greater than  $30^\circ$  (the value  $\theta = 0$  corresponding to a non-skew deck);
- the nominal depth  $h$  of the steel beams complies with:  $210 \text{ mm} \leq h \leq 1100 \text{ mm}$ ;
- the spacing  $s_w$  of webs of the steel beams should not exceed the lesser of  $h/3 + 600 \text{ mm}$  and  $750 \text{ mm}$ , where  $h$  is the nominal depth of the steel beams in mm;
- the concrete cover  $c_{st}$  above the steel beams satisfies the conditions:

$$c_{st} \geq 70 \text{ mm}, \quad c_{st} \leq 150 \text{ mm}, \quad c_{st} \leq h/3, \quad c_{st} \leq x_{pl} - t_f$$

where  $x_{pl}$  is the distance between the plastic neutral axis for sagging bending and the extreme fibre of the concrete in compression, and  $t_f$  is the thickness of the steel flange;

- the concrete cover to the side of an encased steel flange is not less than  $80 \text{ mm}$ ;



- the clear distance  $s_f$  between the upper flanges of the steel beams is not less than 150 mm, so as to allow pouring and compaction of concrete;
- the soffit of the lower flange of the steel beams is not encased;
- a bottom layer of transverse reinforcement passes through the webs of the steel beams, and is anchored beyond the end steel beams, and at each end of each bar, so as to develop its yield strength in accordance with 8.4 of EN 1992-1-1: 2004; ribbed bars in accordance with EN 1992-1-1: 2004, 3.2.2 and Annex C are used; their diameter is not less than 16 mm and their spacing is not more than 300 mm;
- normal-density concrete is used;
- the surface of the steel beams should be descaled. The soffit, the upper surfaces and the edges of the lower flange of the steel beams should be protected against corrosion;
- for road and railway bridges the holes in the webs of the steel section should be drilled.

### 6.3.2 General

- (1) Filler beam decks should be designed for ultimate limit states according to 6.3.2 to 6.3.5 and for the serviceability limit state according to Section 7.
- (2) Steel beams with bolted connections and/or welding should be checked against fatigue.
- (3) Composite cross-sections should be classified according to 5.5.3.
- (4) Mechanical shear connection need not be provided.

### 6.3.3 Bending moments

- (1) The design resistance of composite cross-sections to bending moments should be determined according to 6.2.1. Where the vertical shear force  $V_{a,Ed}$  on the steel section exceeds half of the shear resistance given by 6.3.4, allowance should be made for its effect on the resistance moment in accordance with 6.2.2.4 (2) and (3).
- (2) The design resistance of reinforced concrete sections to transverse bending moments should be determined according to EN 1992-2.

### 6.3.4 Vertical shear

- (1) The resistance of the composite cross-section to vertical shear should be taken as the resistance of the structural steel section  $V_{pl,a,Rd}$  unless the value of a contribution from the reinforced concrete part has been established in accordance with EN 1992-2.
- (2) Unless a more accurate analysis is used, the part  $V_{c,Ed}$  of the total vertical shear  $V_{Ed}$  acting on the reinforced concrete part may be taken as  $V_{c,Ed} = V_{Ed} (M_{s,Rd}/M_{pl,Rd})$ , with  $M_{s,Rd} = N_s \cdot z_s = A_s \cdot f_{sd} \cdot z_s$ . The lever arm  $z_s$  is shown in Figure 6.9 for a filler-beam deck in Class 1 or 2.

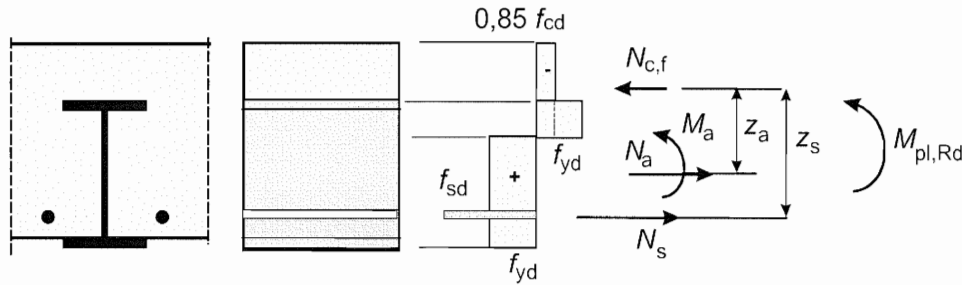

Figure 6.9: Stress distribution at  $M_{Rd}$  for part of a filler-beam deck in Class 1 or 2

(3) The design resistance to vertical shear of reinforced concrete sections between filler beams should be verified according to EN 1992.

### 6.3.5 Resistance and stability of steel beams during execution

(1) Steel beams before the hardening of concrete should be verified according to EN 1993-1-1: 2005 and EN 1993-2.

## 6.4 Lateral-torsional buckling of composite beams

### 6.4.1 General

(1) A steel flange that is attached to a concrete or composite slab by shear connection in accordance with 6.6 may be assumed to be laterally stable, provided that lateral instability of the concrete slab is prevented.

(2) All other steel flanges in compression should be checked for lateral stability.

(3) The methods in EN 1993-1-1: 2005, 6.3.2.1-6.3.2.3 and, more generally, 6.3.4 are applicable to the steel section on the basis of the cross-sectional forces on the composite section, taking into account effects of sequence of construction in accordance with 5.4.2.4. The lateral and elastic torsional restraint at the level of the shear connection to the concrete slab may be taken into account.

### 6.4.2 Beams in bridges with uniform cross-sections in Class 1, 2 or 3

(1) For beams with a uniform steel cross-section in Class 1, 2, or 3, restrained in accordance with 6.4.2(5), the design buckling resistance moment should be taken as:

$$M_{b,Rd} = \chi_{LT} M_{Rd} \quad (6.6)$$

where :

$\chi_{LT}$  is the reduction factor for lateral-torsional buckling corresponding to the relative slenderness  $\bar{\lambda}_{LT}$ , and

$M_{Rd}$  is the design resistance moment at the relevant cross-section.

Values of the reduction factor  $\chi_{LT}$  may be obtained from EN 1993-1-1: 2005, 6.3.2.

(2) For cross-sections in Class 1 or 2,  $M_{Rd} = M_{pl,Rd}$ , determined according to 6.2.1.2.

(3) For cross-sections in Class 3,  $M_{Rd}$  should be taken as  $M_{cl,Rd}$  given by expression (6.4), but as the design bending moment that causes either a tensile stress  $f_{sd}$  in the reinforcement or a stress  $f_{yd}$  in an extreme fibre of the steel section, whichever is the smaller.

(4) The relative slenderness  $\bar{\lambda}_{LT}$  may be calculated from:

$$\bar{\lambda}_{LT} = \sqrt{\frac{M_{Rk}}{M_{cr}}} \quad (6.7)$$

where:

$M_{Rk}$  is the resistance moment of the composite section using the characteristic material properties and the method specified for  $M_{Rd}$ ;

$M_{cr}$  is the elastic critical moment for lateral-torsional buckling determined at the relevant cross-section.

(5) Where the slab is attached to one or more supporting steel members which are approximately parallel to the composite beam considered and the conditions (a) and (b) below are satisfied, the calculation of the elastic critical moment,  $M_{cr}$ , may be based on the "continuous inverted-U frame" model. This model takes into account the lateral displacement of the bottom flange causing bending of the steel web, and the rotation of the top flange as shown in Figure 6.10.

- a) The top flange of the steel member is attached to a reinforced concrete slab by shear connectors in accordance with 6.6.
- b) At each support of the steel member, the bottom flange is laterally restrained and the web is stiffened. Elsewhere, the web is un-stiffened.

(6) At the level of the top steel flange, a rotational stiffness  $k_s$  per unit length of steel beam may be adopted to represent the U-frame model by a beam alone:

$$k_s = \frac{k_1 k_2}{k_1 + k_2} \quad (6.8)$$

where:

$k_1$  is the flexural stiffness of the cracked concrete slab in the direction transverse to the steel beam, which may be taken as:

$$k_1 = \alpha E_a I_2 / a \quad (6.9)$$

where  $\alpha = 2$  for  $k_1$  for an edge beam, with or without a cantilever, and  $\alpha = 3$  for an inner beam. For inner beams in a bridge deck with four or more similar beams,  $\alpha = 4$  may be used.

$a$  is the spacing between the parallel beams;

$E_a I_2$  is the "cracked" flexural stiffness per unit width of the concrete or composite slab, as defined in 1.5.2.12, where  $I_2$  should be taken as the lowest of the value at midspan, for sagging bending, and the values at the supporting steel members, for hogging bending;

$k_2$  is the flexural stiffness of the steel web, to be taken as:

$$k_2 = \frac{E_a t_w^3}{4(1 - \nu_a^2) h_s} \quad (6.10)$$

where  $\nu_a$  is Poisson's ratio for steel and  $h_s$  and  $t_w$  are defined in Figure 6.10.

(7) In the U-frame model, the favourable effect of the St. Venant torsional stiffness,  $G_a I_{at}$ , of the steel section may be taken into account for the calculation of  $M_{cr}$ .

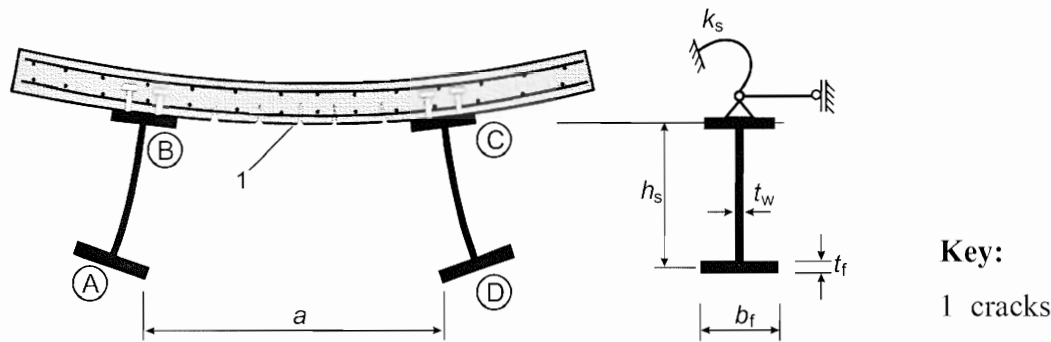

Figure 6.10: U-frame model

### 6.4.3 General methods for buckling of members and frames

#### 6.4.3.1 General method

(1) For composite members outside the scope of 6.4.2 (1) or 6.7 and for composite frames EN 1993-2, 6.3.4 is applicable. For the determination of  $\alpha_{ult}$  and  $\alpha_{crit}$ , appropriate resistances and stiffnesses of concrete and composite members should be used, in accordance with EN 1992 and EN 1994.

#### 6.4.3.2 Simplified method

(1) Clause 6.3.4.2 and Annex D2.4 of EN 1993-2 are applicable to structural steel flanges of composite beams and chords of composite trusses. Where restraint is provided by concrete or composite members, appropriate elastic stiffnesses should be used, in accordance with EN 1992 and EN 1994.

## 6.5 Transverse forces on webs

### 6.5.1 General

(1) The rules given in EN 1993-1-5, 6 to determine the design resistance of an unstiffened or stiffened web to transverse forces applied through a flange are applicable to the non-composite steel flange of a composite beam, and to the adjacent part of the web.

(2) If the transverse force acts in combination with bending and axial force, the resistance should be verified according to EN 1993-1-5, 7.2.

### 6.5.2 Flange-induced buckling of webs

(1) EN 1993-1-5, 8 is applicable provided that area  $A_{fc}$  is taken equal to the area of the non-composite steel flange or the transformed area of the composite steel flange taking into account the modular ratio for short-term loading, whichever is the smaller.

## 6.6 Shear connection

### 6.6.1 General

#### 6.6.1.1 Basis of design

(1) Clause 6.6 is applicable to composite beams and, as appropriate, to other types of composite member.

(2)P Shear connection and transverse reinforcement shall be provided to transmit the longitudinal shear force between the concrete and the structural steel element, ignoring the effect of natural bond between the two.

(3)P Shear connectors shall have sufficient deformation capacity to justify any inelastic redistribution of shear assumed in design.

(4)P Ductile connectors are those with sufficient deformation capacity to justify the assumption of ideal plastic behaviour of the shear connection in the structure considered.

(5) A connector may be taken as ductile if the characteristic slip capacity  $\delta_{ik}$  is at least 6mm.

**NOTE:** An evaluation of  $\delta_{ik}$  is given in Annex B of Part 1-1.

(6)P Where two or more different types of shear connection are used within the same span of a beam, account shall be taken of any significant difference in their load-slip properties.

(7)P Shear connectors shall be capable of preventing separation of the concrete element from the steel element, except where separation is prevented by other means.

(8) To prevent separation of the slab, shear connectors should be designed to resist a nominal ultimate tensile force, perpendicular to the plane of the steel flange, of at least 0.1 times the design ultimate shear resistance of the connectors. If necessary they should be supplemented by anchoring devices.

(9) Headed stud shear connectors in accordance with 6.6.5.7 may be assumed to provide sufficient resistance to uplift, unless the shear connection is subjected to direct tension.

(10)P Longitudinal shear failure and splitting of the concrete slab due to concentrated forces applied by the connectors shall be prevented.

(11) If the detailing of the shear connection is in accordance with the appropriate provisions of 6.6.5 and the transverse reinforcement is in accordance with 6.6.6, compliance with 6.6.1.1(10) may be assumed.

(12) Where a method of interconnection, other than the shear connectors included in 6.6, is used to transfer shear between a steel element and a concrete element, the behaviour assumed in design should be based on tests and supported by a conceptual model. The design of the composite member should conform to the design of a similar member employing shear connectors included in 6.6, in so far as practicable.

(13) Adjacent to cross frames and vertical web stiffeners, and for composite box girders, the effects of bending moments at the steel-concrete interface, about an axis parallel to the axis of the steel beam, caused by deformations of the slab or the steel member should be considered.

**NOTE:** Reference to further guidance may be given in the National Annex.

#### **6.6.1.2 Ultimate limit states other than fatigue**

(1) For verifications for ultimate limit states, the size and spacing of shear connectors may be kept constant over any length where the design longitudinal shear per unit length does not exceed the longitudinal design shear resistance by more than 10%. Over every such length, the total design longitudinal shear force should not exceed the total design shear resistance.

## 6.6.2 Longitudinal shear force in beams for bridges

### 6.6.2.1 Beams in which elastic or non-linear theory is used for resistances of cross-sections

(1) For any load combination and arrangement of design actions, the longitudinal shear per unit length at the interface between steel and concrete in a composite member,  $v_{L,Ed}$ , should be determined from the rate of change of the longitudinal force in either the steel or the concrete element of the composite section. Where elastic theory is used for calculating resistances of sections, the envelope of transverse shear force in the relevant direction may be used.

(2) In general the elastic properties of the uncracked section should be used for the determination of the longitudinal shear force, even where cracking of concrete is assumed in global analysis. The effects of cracking of concrete on the longitudinal shear force may be taken into account, if in global analysis and for the determination of the longitudinal shear force account is taken of the effects of tension stiffening and possible over-strength of concrete.

(3) Where concentrated longitudinal shear forces occur, account should be taken of the local effects of longitudinal slip; for example, as provided in 6.6.2.3 and 6.6.2.4. Otherwise, the effects of longitudinal slip may be neglected.

(4) For composite box girders, the longitudinal shear force on the connectors should include the effects of bending and torsion, and also of distortion according to 6.2.7 of EN 1993-2, if appropriate. For box girders with a flange designed as a composite plate, see 9.4.

### 6.6.2.2 Beams in bridges with cross-sections in Class 1 or 2

(1) In members with cross-sections in Class 1 or 2, if the total design bending moment  $M_{Ed,max} = M_{a,Ed} + M_{c,Ed}$  exceeds the elastic bending resistance  $M_{cl,Rd}$ , account should be taken of the non-linear relationship between transverse shear and longitudinal shear within the inelastic lengths of the member.  $M_{a,Ed}$  and  $M_{c,Ed}$  are defined in 6.2.1.4 (6).

(2) This paragraph applies to regions where the concrete slab is in compression, as shown in Figure 6.11. Shear connectors should be provided within the inelastic length  $L_{A-B}$  to resist the longitudinal shear force  $V_{L,Ed}$ , resulting from the difference between the normal forces  $N_{cd}$  and  $N_{c,el}$  in the concrete slab at the cross-sections B and A, respectively. The bending resistance  $M_{cl,Rd}$  is defined in 6.2.1.4. If the maximum bending moment  $M_{Ed,max}$  at section B is smaller than the plastic bending resistance  $M_{pl,Rd}$ , the normal force  $N_{cd}$  at section B may be determined according to 6.2.1.4(6) and Figure 6.6, or alternatively using the simplified linear relationship according to Figure 6.11.

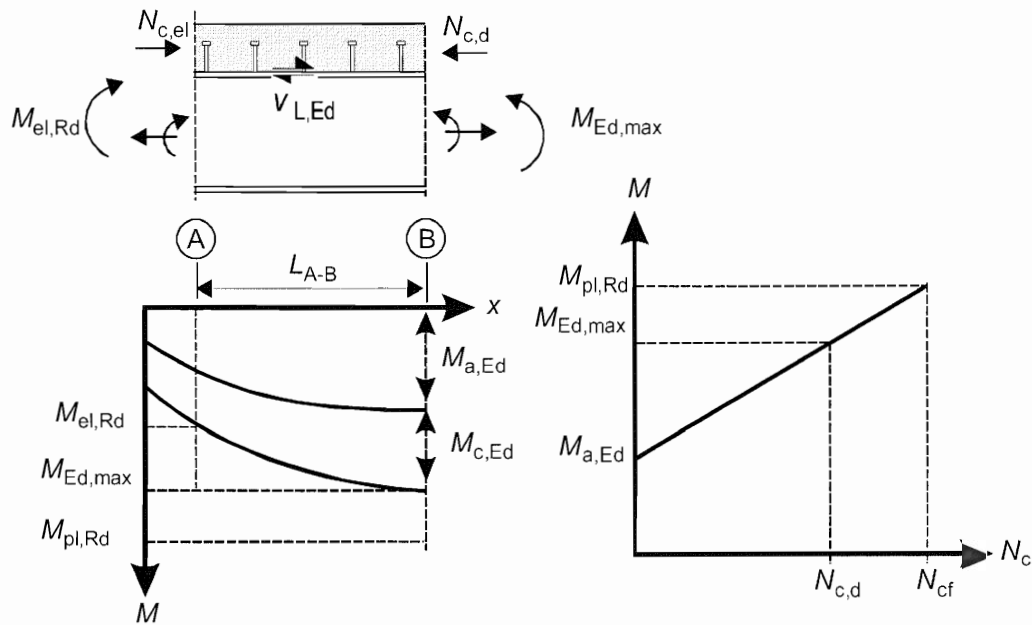

**Figure 6.11: Determination of longitudinal shear in beams with inelastic behaviour of cross sections**

(3) Where the effects of inelastic behaviour of a cross-section with the concrete slabs in tension are taken into account, the longitudinal shear forces and their distribution should be determined from the differences of forces in the reinforced concrete slab within the inelastic length of the beam, taking into account effects from tension stiffening of concrete between cracks and possible over-strength of concrete in tension. For the determination of  $M_{cl,Rd}$  6.2.1.4(7) and 6.2.1.5 applies.

(4) Unless the method according to (3) is used, the longitudinal shear forces should be determined by elastic analysis with the cross-section properties of the uncracked section taking into account effects of sequence of construction.

### 6.6.2.3 Local effects of concentrated longitudinal shear force due to introduction of longitudinal forces

(1) Where a force  $F_{Ed}$  parallel to the longitudinal axis of the composite beam is applied to the concrete or steel element by a bonded or unbonded tendon, the distribution of the concentrated longitudinal shear force  $V_{L,Ed}$  along the interface between steel and concrete, should be determined according to (2) or (3). The distribution of  $V_{L,Ed}$  caused by several forces  $F_{Ed}$  should be obtained by summation.

(2) The force  $V_{L,Ed}$  may be assumed to be distributed along a length  $L_v$  of shear connection with a maximum shear force per unit length given by equation (6.12) and (Fig. 6.12a) for load introduction within a length of a concrete flange and by equation (6.13) and (Fig. 6.12b) at an end of a concrete flange.

$$v_{L,Ed,max} = V_{L,Ed} / (e_d + b_{eff}/2), \quad (6.12)$$

$$v_{L,Ed,max} = 2 V_{L,Ed} / (e_d + b_{eff}/2). \quad (6.13)$$

where

- $b_{\text{eff}}$  is the effective width for global analysis, given by 5.4.1.2,
- $e_d$  is either  $2e_h$  or  $2e_v$  (the length over which the force  $F_{\text{Ed}}$  is applied may be added to  $e_d$ )
- $e_h$  is the lateral distance from the point of application of force  $F_{\text{Ed}}$  to the relevant steel web, if it is applied to the slab,
- $e_v$  is the vertical distance from the point of application of force  $F_{\text{Ed}}$  to the plane of the shear connection concerned, if it is applied to the steel element.

(3) Where stud shear connectors are used, at ultimate limit states a rectangular distribution of shear force per unit length may be assumed within the length  $L_v$ , so that within a length of concrete flange,

$$v_{\text{L,Ed,max}} = V_{\text{L,Ed}} / (e_d + b_{\text{eff}}) \quad (6.14)$$

and at an end of a flange,

$$v_{\text{L,Ed,max}} = 2 V_{\text{L,Ed}} / (e_d + b_{\text{eff}}). \quad (6.15)$$

(4) In the absence of a more precise determination, the force  $F_{\text{Ed}} - V_{\text{L,Ed}}$  may be assumed to disperse into the concrete or steel element at an angle of spread  $2\beta$ , where  $\beta = \arctan 2/3$ .



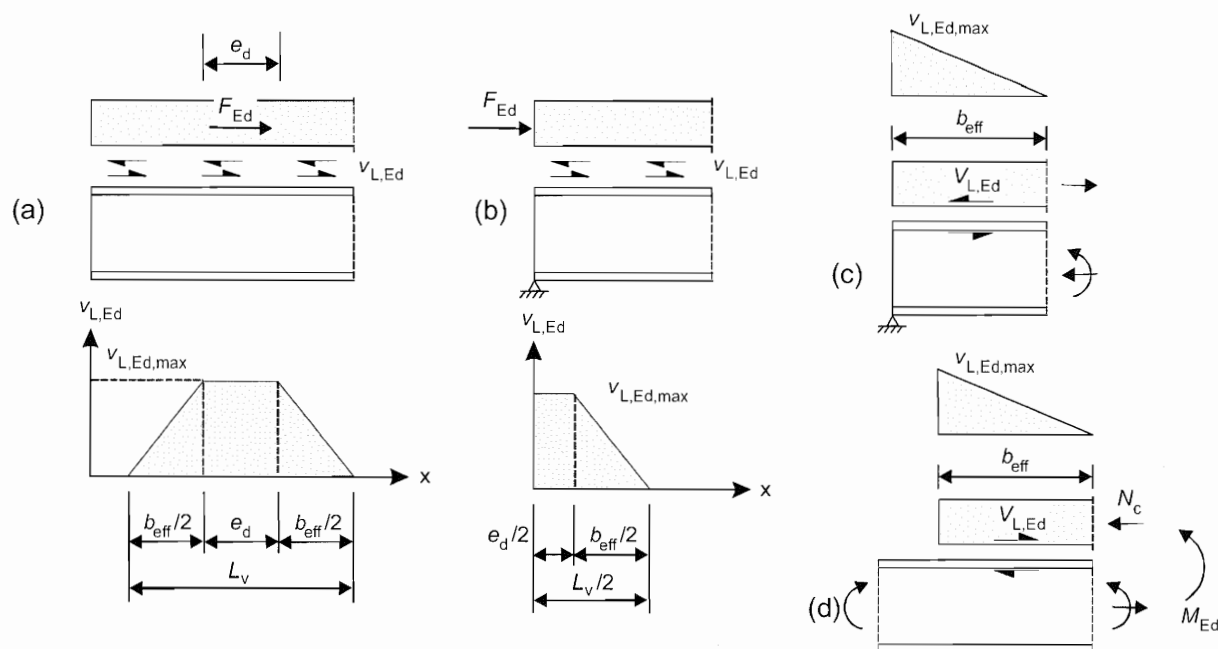

**Figure 6.12: Distribution of longitudinal shear force along the interface**

#### 6.6.2.4 Local effects of concentrated longitudinal shear forces at sudden change of cross-sections

(1) Concentrated longitudinal shear at the end of the concrete slab, e.g. due to the primary effects of shrinkage and thermal actions in accordance with EN 1991-1-5: 2003 should be considered (see Figure 6.12c), and taken into account where appropriate. This applies also for intermediate stages of construction of a concrete slab (Fig. 6.12d).

(2) Concentrated longitudinal shear at a sudden change of cross-sections, e.g. change from steel to composite section according to Fig. 6.12d, should be taken into account.

(3) Where the primary effects of temperature and shrinkage cause a design longitudinal shear force  $V_{L,Ed}$ , to be transferred across the interface between steel and concrete at each free end of the member considered, its distribution may be assumed to be triangular, with a maximum shear force per unit length (Figure 6.12c and d)

$$v_{L,Ed,max} = 2 V_{L,Ed} / b_{eff} \quad (6.16)$$

at the free end of the slab, where  $b_{eff}$  is the effective width for global analysis, given by 5.4.1.2(4). Where stud shear connectors are used, for the ultimate limit state the distribution may alternatively be assumed to be rectangular along a length  $b_{eff}$  adjacent to the free end of the slab.

(4) For calculating the primary effects of shrinkage at intermediate stages of the construction of a concrete slab, the equivalent span for the determination of the width  $b_{eff}$  in 6.6.2.4 should be taken as the continuous length of concrete slab where the shear connection is effective, within the span considered.

(5) Where at a sudden change of cross-section according to Figure 6.12d the concentrated longitudinal shear force results from the force  $N_c$  due to bending, the distribution given by (3) may be used.

(6) The forces transferred by shear connectors should be assumed to disperse into the concrete slab at an angle of spread  $2\beta$ , where  $\beta = \arctan 2/3$ .

### 6.6.3 Headed stud connectors in solid slabs and concrete encasement

#### 6.6.3.1 Design resistance

(1) The design shear resistance of a headed stud automatically welded in accordance with EN 14555 should be determined from:

$$P_{Rd} = \frac{0.8 f_u \pi d^2 / 4}{\gamma_V} \quad (6.18)$$

or:

$$P_{Rd} = \frac{0.29 \alpha d^2 \sqrt{f_{ck} E_{cm}}}{\gamma_V} \quad (6.19)$$

whichever is smaller, with:

$$\alpha = 0.2 \left( \frac{h_{sc}}{d} + 1 \right) \quad \text{for } 3 \leq h_{sc} / d \leq 4 \quad (6.20)$$

$$\alpha = 1 \quad \text{for } h_{sc} / d > 4 \quad (6.21)$$

where:

$\gamma_V$  is the partial factor;

$d$  is the diameter of the shank of the stud,  $16 \text{ mm} \leq d \leq 25 \text{ mm}$ ;

$f_u$  is the specified ultimate tensile strength of the material of the stud but not greater than  $500 \text{ N/mm}^2$ ;

$f_{ck}$  is the characteristic cylinder compressive strength of the concrete at the age considered, of density not less than  $1750 \text{ kg/m}^3$ ;

$h_{sc}$  is the overall nominal height of the stud.

**NOTE:** The value for  $\gamma_V$  may be given in the National Annex. The recommended value for  $\gamma_V$  is 1.25.

(2) The weld collars should comply with the requirements of EN 13918.

(3) Where studs are arranged in a way such that splitting forces occur in the direction of the slab thickness, (1) is not applicable.

(4) For studs of diameter greater than 25 mm, or studs with weld collars which do not comply with the requirements of EN ISO 13918, the formulae in 6.6.3.1(1) should be verified by tests, see B.2 of EN 1994-1-1: 2004, before being used.

### 6.6.3.2 Influence of tension on shear resistance

(1) Where headed stud connectors are subjected to direct tensile force in addition to shear, the design tensile force per stud  $F_{\text{ten}}$  should be calculated.

(2) If  $F_{\text{ten}} \leq 0.1P_{\text{Rd}}$ , where  $P_{\text{Rd}}$  is the design shear resistance defined in 6.6.3.1, the tensile force may be neglected.

(3) If  $F_{\text{ten}} > 0.1P_{\text{Rd}}$ , the connection is not within the scope of EN 1994.

### 6.6.4 Headed studs that cause splitting in the direction of the slab thickness

(1) Where, in bridges, headed stud connectors are arranged in such a way that splitting forces can occur in the direction of the slab thickness (see Fig. 6.13) and where there is no transverse shear, the design resistance to longitudinal shear may be determined according to 6.6.3.1(1), provided that (2) and (3) are fulfilled.

**NOTE:** Where the conditions in (1) are not fulfilled, design rules are given in the informative Annex C

(2) Transverse reinforcement should be provided, as shown in Figure 6.13, such that  $e_v \geq 6d$ , and the anchoring length  $v$  should be greater than or equal to  $14d$ .

(3) The splitting force should be resisted by stirrups which should be designed for a tensile force  $0.3PR_d$  per stud connector. The spacing of these stirrups should not exceed the smaller of  $18d$  and the longitudinal spacing of the connectors.

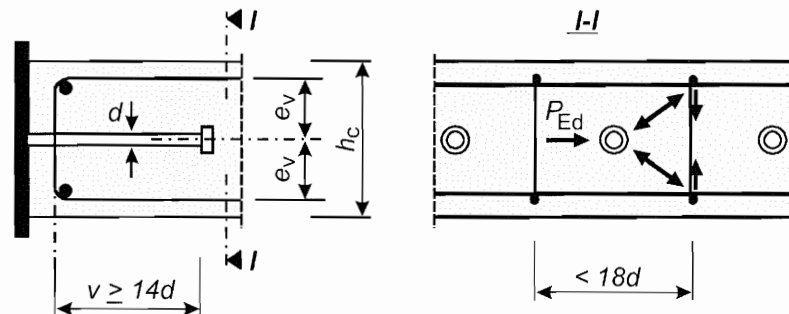

Figure 6.13: Local reinforcement for splitting forces

### 6.6.5 Detailing of the shear connection and influence of execution

#### 6.6.5.1 Resistance to separation

(1) The surface of a connector that resists separation forces (for example, the underside of the head of a stud) should extend not less than 30 mm clear above the bottom reinforcement, see Figure 6.14.

#### 6.6.5.2 Cover and concreting for bridges

(1)P The detailing of shear connectors shall be such that concrete can be adequately compacted around the base of the connector.

(2) Cover over shear connectors should be not less than that required for reinforcement adjacent to the same surface of concrete.

(3) In execution, the rate and sequence of concreting should be required to be such that partly matured concrete is not damaged as a result of limited composite action occurring from deformation of the steel beams under subsequent concreting operations. Wherever possible, deformation should not be imposed on a shear connection until the concrete has reached a cylinder strength of at least  $20 \text{ N/mm}^2$ .

### 6.6.5.3 Local reinforcement in the slab

(1) Where the shear connection is adjacent to a longitudinal edge of a concrete slab, transverse reinforcement provided in accordance with 6.6.6 should be fully anchored in the concrete between the edge of the slab and the adjacent row of connectors.

(2) To prevent longitudinal splitting of the concrete flange caused by the shear connectors, the following additional recommendations should be applied where the distance from the edge of the concrete flange to the centreline of the nearest row of shear connectors is less than 300 mm:

- a) transverse reinforcement should be supplied by U-bars passing around the shear connectors,
- b) where headed studs are used as shear connectors, the distance from the edge of the concrete flange to the centre of the nearest stud should not be less than  $6d$ , where  $d$  is the nominal diameter of the stud, and the U-bars should be not less than  $0,5d$  in diameter and
- c) the U-bars should be placed as low as possible while still providing sufficient bottom cover.

(3)P At the end of a composite cantilever, sufficient local reinforcement shall be provided to transfer forces from the shear connectors to the longitudinal reinforcement.

### 6.6.5.4 Haunches other than formed by profiled steel sheeting

(1) Where a concrete haunch is used between the steel section and the soffit of the concrete slab, the sides of the haunch should lie outside a line drawn at  $45^\circ$  from the outside edge of the connector, see Figure 6.14.

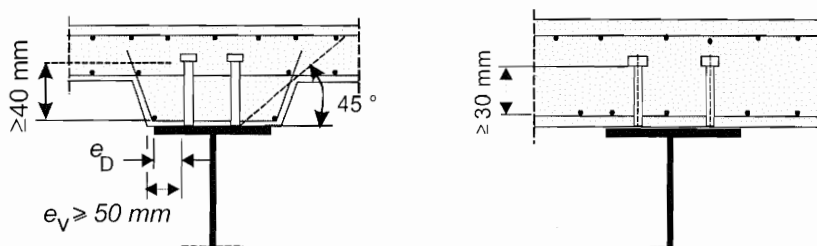

Figure 6.14: Detailing

(2) The nominal concrete cover from the side of the haunch to the connector should be not less than 50 mm.

(3) Transverse reinforcing bars sufficient to satisfy the requirements of 6.6.6 should be provided in the haunch at not less than 40 mm clear below the surface of the connector that resists uplift.

### 6.6.5.5 Spacing of connectors

(1)P Where it is assumed in design that the stability of either the steel or the concrete member is ensured by the connection between the two, the spacing of the shear connectors shall be sufficiently close for this assumption to be valid.

(2) Where a steel compression flange that would otherwise be in  $\text{AC1}$  Class 3 or Class 4  $\text{AC1}$  is assumed to be in Class 1 or Class 2 because of restraint from shear connectors, the centre-to-centre spacing of the shear connectors in the direction of compression should be not greater than the following limits:

- where the slab is in contact over the full length (e.g. solid slab):  $22 t_f \sqrt{235/f_y}$
- where the slab is not in contact over the full length (e.g. slab with ribs transverse to the beam):  $15 t_f \sqrt{235/f_y}$

where:

- $t_f$  is the thickness of the flange;
- $f_y$  is the nominal yield strength of the flange in N/mm<sup>2</sup>.

In addition, the clear distance from the edge of a compression flange to the nearest line of shear connectors should be not greater than  $9 t_f \sqrt{235/f_y}$ .

(3) The maximum longitudinal centre-to-centre spacing of individual shear connectors should not exceed the lesser of four times the slab thickness and 800 mm.

(4) Connectors may be placed in groups, with the spacing of groups greater than that specified for individual shear connectors, provided that consideration is given in design to:

- the non-uniform flow of longitudinal shear,
- the greater possibility of slip and vertical separation between the slab and the steel member,
- buckling of the steel flange, and
- the local resistance of the slab to the concentrated force from the connectors.

#### 6.6.5.6 Dimensions of the steel flange

(1)P The thickness of the steel plate or flange to which a connector is welded shall be sufficient to allow proper welding and proper transfer of load from the connector to the plate without local failure or excessive deformation.

(2) The distance  $e_D$  between the edge of a connector and the edge of the flange of the beam to which it is welded, see Figure 6.14, should not be less than 25 mm.

#### 6.6.5.7 Headed stud connectors

(1) The overall height of a stud should be not less than  $3d$ , where  $d$  is the diameter of the shank.

(2) The head should have a diameter of not less than  $1,5d$  and a depth of not less than  $0,4d$ .

(3) For elements in tension and subjected to fatigue loading, the diameter of a welded stud should not exceed 1,5 times the thickness of the flange to which it is welded, unless test information is provided to establish the fatigue resistance of the stud as a shear connector. This applies also to studs directly over a web.

(4) The spacing of studs in the direction of the shear force should be not less than  $5d$ ; the spacing in the direction transverse to the shear force should be not less than  $2,5d$  in solid slabs and  $4d$  in other cases.

(5) Except when the studs are located directly over the web, the diameter of a welded stud should be not greater than 2,5 times the thickness of that part to which it is welded, unless test information is provided to establish the resistance of the stud as a shear connector.

## 6.6.6 Longitudinal shear in concrete slabs

### 6.6.6.1 General

(1)P Transverse reinforcement in the slab shall be designed for the ultimate limit state so that premature longitudinal shear failure or longitudinal splitting shall be prevented.

(2)P The design longitudinal shear stress for any potential surface of longitudinal shear failure within the slab shall not exceed the design longitudinal shear strength of the shear surface considered.

(3) The length of the shear surface b-b shown in Figure 6.15 should be taken as equal to  $2h_{sc}$  plus the head diameter for a single row of stud shear connectors or staggered stud connectors, or as equal to  $(2h_{sc} + s_t)$  plus the head diameter for stud shear connectors arranged in pairs, where  $h_{sc}$  is the height of the studs and  $s_t$  is the transverse spacing centre-to-centre of the studs.

(4) The design longitudinal shear per unit length of beam on a shear surface should be determined in accordance with 6.6.2 and be consistent with the design and spacing of the shear connectors. Account may be taken of the variation of longitudinal shear across the width of the concrete flange.

(5) For each type of shear surface considered, the design longitudinal shear stress  $v_{Ed}$  should be determined from the design longitudinal shear per unit length of beam, taking account of the number of shear planes and the length of shear surface.

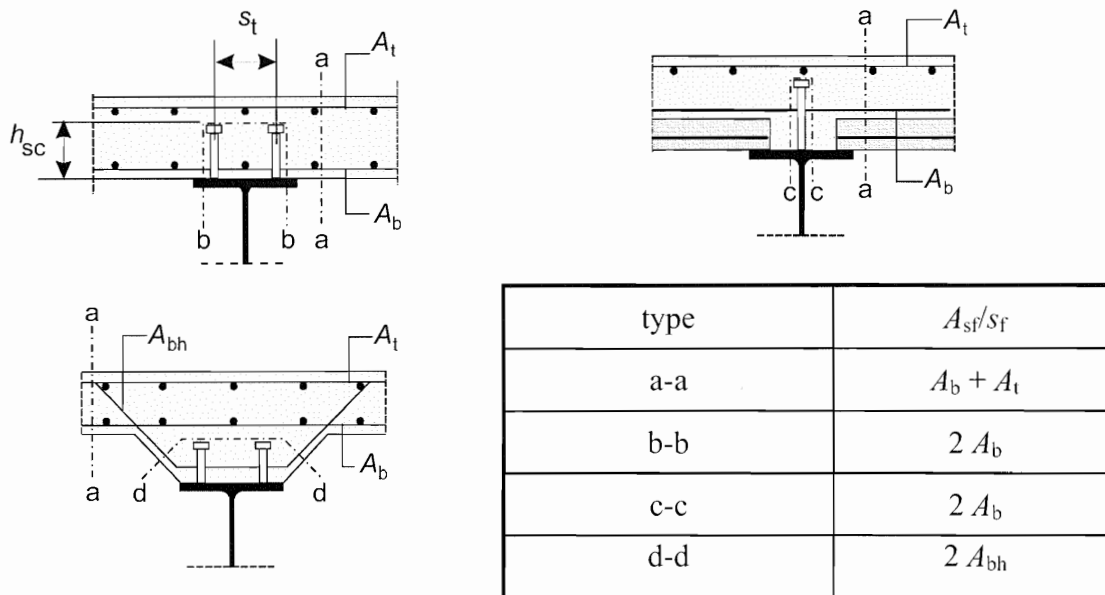

Figure 6.15: Typical potential surfaces of shear failure

### 6.6.6.2 Design resistance to longitudinal shear

(1) The design shear strength of the concrete flange (shear planes a-a illustrated in Figure 6.15) should be determined in accordance with EN 1992-1-1: 2004, 6.2.4.

(2) In the absence of a more accurate calculation the design shear strength of any surface of potential shear failure in the flange or a haunch may be determined from EN 1992-1-1: 2004, 6.2.4(4). For a shear surface passing around the shear connectors (e.g. shear surface b-b in Figure 6.15), the dimension  $h_f$  should be taken as the length of the shear surface.

(3) The effective transverse reinforcement per unit length,  $A_{sf}/s_f$  in EN 1992-1-1: 2004, should be as shown in Figure 6.15, in which  $A_b$ ,  $A_t$  and  $A_{bh}$  are areas of reinforcement per unit length of beam anchored in accordance with EN 1992-1-1: 2004, 8.4 for longitudinal reinforcement.

(4) Where a combination of pre-cast elements and in-situ concrete is used, the resistance to longitudinal shear should be determined in accordance with EN 1992-1-1: 2004, 6.2.5.

### 6.6.6.3 Minimum transverse reinforcement

(1) The minimum area of reinforcement should be determined in accordance with EN 1992-1-1: 2004, 9.2.2(5) using definitions appropriate to transverse reinforcement.

## 6.7 Composite columns and composite compression members

### 6.7.1 General

(1)P Clause 6.7 applies for the design of composite columns and composite compression members with concrete encased sections, partially encased sections and concrete filled rectangular and circular tubes, see Figure 6.17.

(2)P This clause applies to columns and compression members with steel grades S235 to S460 and normal weight concrete of strength classes C20/25 to C50/60.

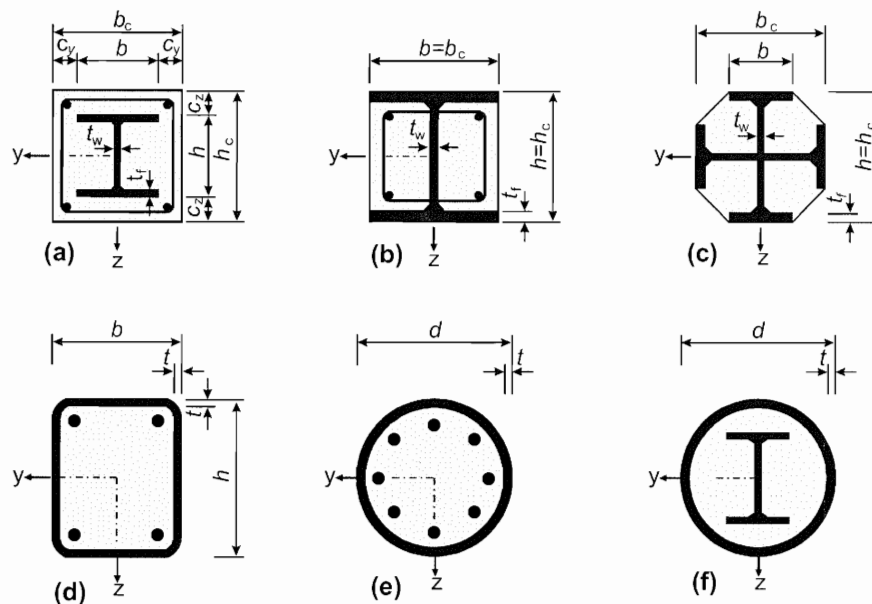

Figure 6.17: Typical cross-sections of composite columns and notation

(3) This clause applies to isolated columns and columns and composite compression members in framed structures where the other structural members are either composite or steel members.

(4) The steel contribution ratio  $\delta$  should fulfil the following condition:

$$0.2 \leq \delta \leq 0.9 \quad (6.27)$$

where  $\delta$  is defined in 6.7.3.3(1).

(5) Composite columns or compression members of any cross-section should be checked for:

- resistance of the member in accordance with 6.7.2 or 6.7.3;
- resistance to local buckling in accordance with (8) and (9) below;
- introduction of loads in accordance with 6.7.4.2 and
- resistance to shear between steel and concrete elements in accordance with 6.7.4.3.

(6) Two methods of design are given:

- a general method in 6.7.2 whose scope includes members with non-symmetrical or non-uniform cross-sections over the column length and
- a simplified method in 6.7.3 for members of doubly symmetrical and uniform cross section over the member length.

(7) For composite compression members subjected to bending moments and normal forces resulting from independent actions, the partial factor  $\gamma_F$  for those internal forces that lead to an increase of resistance should be reduced by 20%.

**Table 6.3: Maximum values ( $d/t$ ), ( $h/t$ ) and ( $b/t_f$ ) with  $f_y$  in N/mm<sup>2</sup>**

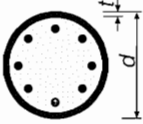
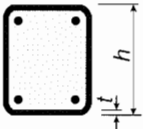
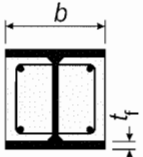
Cross-section	max ( $d/t$ ), max ( $h/t$ ) and max ( $b/t$ )
Circular hollow steel sections 	$\max (d/t) = 90 \frac{235}{f_y}$
Rectangular hollow steel sections 	$\max (h/t) = 52 \sqrt{\frac{235}{f_y}}$
Partially encased I-sections 	$\max (b/t_f) = 44 \sqrt{\frac{235}{f_y}}$

(8)P The influence of local buckling of the steel section on the resistance shall be considered in design.

(9) The effects of local buckling may be neglected for a steel section fully encased in accordance with 6.7.5.1(2), and for other types of cross-section provided the maximum values of Table 6.3 are not exceeded.



## 6.7.2 General method of design

(1)P Design for structural stability shall take account of second-order effects including residual stresses, geometrical imperfections, local instability, cracking of concrete, creep and shrinkage of concrete and yielding of structural steel and of reinforcement. The design shall ensure that instability does not occur for the most unfavourable combination of actions at the ultimate limit state and that the resistance of individual cross-sections subjected to bending, longitudinal force and shear is not exceeded.

(2)P Second-order effects shall be considered in any direction in which failure might occur, if they affect the structural stability significantly.

(3)P Internal forces shall be determined by elasto-plastic analysis.

(4) Plane sections may be assumed to remain plane. Full composite action up to failure may be assumed between the steel and concrete components of the member.

(5)P The tensile strength of concrete shall be neglected. The influence of tension stiffening of concrete between cracks on the flexural stiffness may be taken into account.

(6)P Shrinkage and creep effects shall be considered if they are likely to reduce the structural stability significantly.

(7) For simplification, creep and shrinkage effects may be ignored if the increase in the first-order bending moments due to creep deformations and longitudinal force resulting from permanent loads is not greater than 10%.

(8) The following stress-strain relationships should be used in the non-linear analysis:

- for concrete in compression as given in EN 1992-1-1: 2004, 3.1.5;
- for reinforcing steel as given in EN 1992-1-1: 2004, 3.2.7;
- for structural steel as given in EN 1993-1-1: 2005, 5.4.3(4).

(9) For simplification, instead of the effect of residual stresses and geometrical imperfections, equivalent initial bow imperfections (member imperfections) may be used in accordance with Table 6.5.

## 6.7.3 Simplified method of design

### 6.7.3.1 General and scope

(1) The scope of this simplified method is limited to members of doubly symmetrical and uniform cross-section over the member length with rolled, cold-formed or welded steel sections. The simplified method is not applicable if the structural steel component consists of two or more unconnected sections. The relative slenderness  $\bar{\lambda}$  defined in 6.7.3.3 should fulfil the following condition:

$$\bar{\lambda} \leq 2,0 \quad (6.28)$$

(2) For a fully encased steel section, see Figure 6.17a, limits to the maximum thickness of concrete cover that may be used in calculation are:

$$\max c_z = 0.3h \quad \max c_y = 0.4b \quad (6.29)$$

(3) The longitudinal reinforcement that may be used in calculation should not exceed 6% of the concrete area.

(4) The ratio of the cross-section's depth to width of the composite section should be within the limits 0.2 and 5.0.

### 6.7.3.2 Resistance of cross-sections

(1) The plastic resistance to compression  $N_{pl,Rd}$  of a composite cross-section should be calculated by adding the plastic resistances of its components:

$$N_{pl,Rd} = A_a f_{yd} + 0.85 A_c f_{cd} + A_s f_{sd} \quad (6.30)$$

Expression (6.30) applies for concrete encased and partially concrete encased steel sections. For concrete filled sections the coefficient 0.85 may be replaced by 1.0.

(2) The resistance of a cross-section to combined compression and bending and the corresponding interaction curve may be calculated assuming rectangular stress blocks as shown in Figure 6.18, taking account of the design shear force  $V_{Ed}$  in accordance with (3). The tensile strength of the concrete should be neglected.

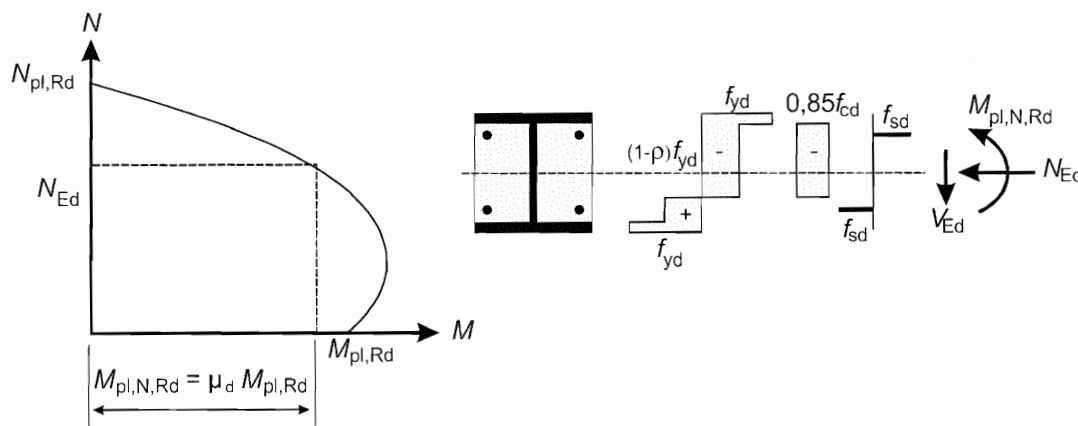

**Figure 6.18: Interaction curve for combined compression and uniaxial bending**

(3) The influence of transverse shear forces on the resistance to bending and normal force should be considered when determining the interaction curve, if the shear force  $V_{a,Ed}$  on the steel section exceeds 50% of the design shear resistance  $V_{pl,a,Rd}$  of the steel section, see 6.2.2.2.

Where  $V_{a,Ed} > 0.5V_{pl,a,Rd}$ , the influence of the transverse shear on the resistance in combined bending and compression should be taken into account by a reduced design steel strength  $(1 - \rho)f_{yd}$  in the shear area  $A_v$  in accordance with 6.2.2.4(2) and Figure 6.18.

The shear force  $V_{a,Ed}$  should not exceed the resistance to shear of the steel section determined according to 6.2.2. The resistance to shear  $V_{c,Ed}$  of the reinforced concrete part should be verified in accordance with EN 1992-1-1: 2004, 6.2.

(4) Unless a more accurate analysis is used,  $V_{Ed}$  may be distributed into  $V_{a,Ed}$  acting on the structural steel and  $V_{c,Ed}$  acting on the reinforced concrete section by:

$$V_{a,Ed} = V_{Ed} \frac{M_{pl,a,Rd}}{M_{pl,Rd}} \quad (6.31)$$

$$V_{c,Ed} = V_{Ed} - V_{a,Ed} \quad (6.32)$$

where:

$M_{pl,a,Rd}$  is the plastic resistance moment of the steel section and

$M_{pl,Rd}$  is the plastic resistance moment of the composite section.

For simplification  $V_{Ed}$  may be assumed to act on the structural steel section alone.

(5) As a simplification, the interaction curve may be replaced by a polygonal diagram (the dashed line in Figure 6.19). Figure 6.19 shows as an example the plastic stress distribution of a fully encased cross section for the points A to D.  $N_{pm,Rd}$  should be taken as  $0.85 f_{cd} A_c$  for concrete encased and partially concrete encased sections, see Figures 6.17a – c, and as  $f_{cd} A_c$  for concrete filled sections, see Figures 6.17d - f.

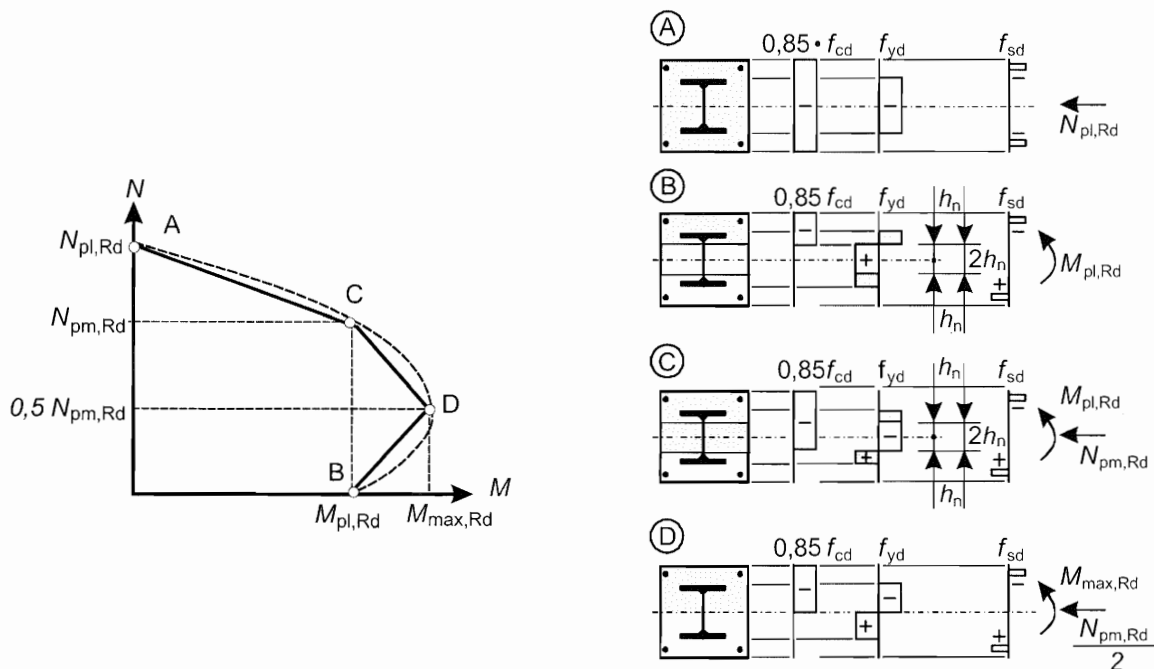

**Figure 6.19: Simplified interaction curve and corresponding stress distributions**

(6) For concrete filled tubes of circular cross-section, account may be taken of increase in strength of concrete caused by confinement provided that the relative slenderness  $\bar{\lambda}$  defined in 6.7.3.3 does not exceed 0.5 and  $e/d < 0,1$ , where  $e$  is the eccentricity of loading given by  $M_{Ed} / N_{Ed}$  and  $d$  is the

external diameter of the column. The plastic resistance to compression may then be calculated from the following expression:

$$N_{pl,Rd} = \eta_a A_a f_{yd} + A_c f_{cd} \left( 1 + \eta_c \frac{t}{d} \frac{f_y}{f_{ck}} \right) + A_s f_{sd} \quad (6.33)$$

where  $t$  is the wall thickness of the steel tube.

For members with  $e = 0$  the values  $\eta_a = \eta_{a0}$  and  $\eta_c = \eta_{c0}$  are given by the following expressions:

$$\eta_{a0} = 0.25 (3 + 2 \bar{\lambda}) \quad (\text{but } \leq 1,0) \quad (6.34)$$

$$\eta_{c0} = 4.9 - 18.5 \bar{\lambda} + 17 \bar{\lambda}^2 \quad (\text{but } \geq 0) \quad (6.35)$$

For members in combined compression and bending with  $0 < e/d \leq 0.1$ , the values  $\eta_a$  and  $\eta_c$  should be determined from (6.36) and (6.37), where  $\eta_{a0}$  and  $\eta_{c0}$  are given by (6.34) and (6.35):

$$\eta_a = \eta_{a0} + (1 - \eta_{a0}) (10 e/d) \quad (6.36)$$

$$\eta_c = \eta_{c0} (1 - 10 e/d) \quad (6.37)$$

For  $e/d > 0.1$ ,  $\eta_a = 1.0$  and  $\eta_c = 0$ .

### 6.7.3.3 Effective flexural stiffness, steel contribution ratio and relative slenderness

(1) The steel contribution ratio  $\delta$  is defined as:

$$\delta = \frac{A_a f_{yd}}{N_{pl,Rd}} \quad (6.38)$$

where  $N_{pl,Rd}$  is the plastic resistance to compression defined in 6.7.3.2(1).

(2) The relative slenderness  $\bar{\lambda}$  for the plane of bending being considered is given by:

$$\bar{\lambda} = \sqrt{\frac{N_{pl,Rk}}{N_{cr}}} \quad (6.39)$$

where:

$N_{pl,Rk}$  is the characteristic value of the plastic resistance to compression given by (6.30) if, instead of the design strengths, the characteristic values are used;

$N_{cr}$  is the elastic critical normal force for the relevant buckling mode, calculated with the effective flexural stiffness  $(EI)_{eff}$  determined in accordance with (3) and (4).

(3) For the determination of the relative slenderness  $\bar{\lambda}$  and the elastic critical force  $N_{cr}$ , the characteristic value of the effective flexural stiffness  $(EI)_{eff}$  of a cross section of a composite column should be calculated from:

$$(EI)_{eff} = E_a I_a + E_s I_s + K_c E_{cm} I_c \quad (6.40)$$

where:

$K_c$  is a correction factor that should be taken as 0.6.

$I_a$ ,  $I_c$ , and  $I_s$  are the second moments of area of the structural steel section, the un-cracked concrete section and the reinforcement for the bending plane being considered.

(4) Account should be taken to the influence of long-term effects on the effective elastic flexural stiffness. The modulus of elasticity of concrete  $E_{cm}$  should be reduced to the value  $E_{c,eff}$  in accordance with the following expression:

$$E_{c,eff} = E_{cm} \frac{1}{1 + (N_{G,Ed} / N_{Ed}) \varphi_t} \quad (6.41)$$

where:

- $\varphi_t$  is the creep coefficient according to 5.4.2.2(2);
- $N_{Ed}$  is the total design normal force;
- $N_{G,Ed}$  is the part of this normal force that is permanent.

#### 6.7.3.4 Methods of analysis and member imperfections

(1) For member verification, analysis should be based on second-order linear elastic analysis.

(2) For the determination of the internal forces the design value of effective flexural stiffness  $(EI)_{eff,II}$  should be determined from the following expression:

$$(EI)_{eff,II} = K_o (E_a I_a + E_s I_s + K_{c,II} E_{cm} I_c) \quad (6.42)$$

where:

- $K_{c,II}$  is a correction factor which should be taken as 0.5;
- $K_o$  is a calibration factor which should be taken as 0.9.

Long-term effects should be taken into account in accordance with 6.7.3.3 (4).

(3) Second-order effects need not to be considered where 5.2.1(3) applies and the elastic critical load is determined with the flexural stiffness  $(EI)_{eff,II}$  in accordance with (2).

(4) The influence of geometrical and structural imperfections may be taken into account by equivalent geometrical imperfections. Equivalent member imperfections for composite columns are given in Table 6.5, where  $L$  is the column length.

(5) Within the column length, second-order effects may be allowed for by multiplying the greatest first-order design bending moment  $M_{Ed}$  by a factor  $k$  given by:

$$k = \frac{\beta}{1 - N_{Ed} / N_{cr,eff}}, \quad \geq 1.0 \quad (6.43)$$

where:

- $N_{cr,eff}$  is the critical normal force for the relevant axis and corresponding to the effective flexural stiffness given in 6.7.3.4(2), with the effective length taken as the column length;
- $\beta$  is an equivalent moment factor given in Table 6.4.

**Table 6.4 Factors  $\beta$  for the determination of moments to second order theory**

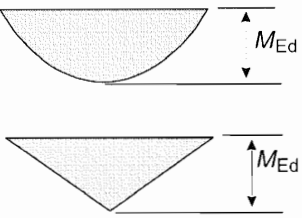
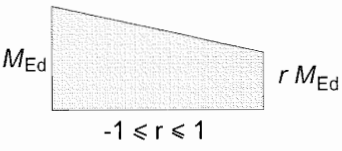
Moment distribution	Moment factors $\beta$	Comment
	<p>First-order bending moments from member imperfection or lateral load:</p> <p style="text-align: center;"><math>\beta = 1.0</math></p>	<p><math>M_{Ed}</math> is the maximum bending moment within the column length ignoring second-order effects</p>
	<p>End moments:</p> <p style="text-align: center;"><math>\beta = 0.66 + 0.44r</math></p> <p>but <math>\beta \geq 0.44</math></p>	<p><math>M_{Ed}</math> and <math>r M_{Ed}</math> are the end moments from first-order or second-order global analysis</p>

### 6.7.3.5 Resistance of members in axial compression

(1) Members may be verified using second order analysis according to 6.7.3.6 taking into account member imperfections.

(2) For simplification for members in axial compression, the design value of the normal force  $N_{Ed}$  should satisfy:

$$\frac{N_{Ed}}{\chi N_{pl,Rd}} \leq 1.0 \tag{6.44}$$

where:

$N_{pl,Rd}$  is the plastic resistance of the composite section according to 6.7.3.2(1), but with  $f_{yd}$  determined using the partial factor  $\gamma_{M1}$  given by EN 1993-1-1: 2005, 6.1(1);

$\chi$  is the reduction factor for the relevant buckling mode given in EN 1993-1-1: 2005, 6.3.1.2 in terms of the relevant relative slenderness  $\bar{\lambda}$ .

The relevant buckling curves for cross-sections of composite columns are given in Table 6.5, where  $\rho_s$  is the reinforcement ratio  $A_s / A_c$ .

**Table 6.5: Buckling curves and member imperfections for composite columns**

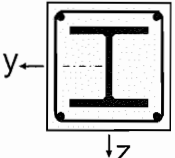
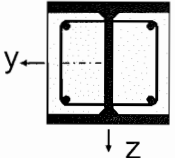
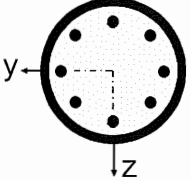
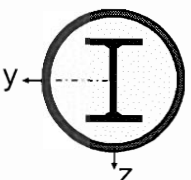
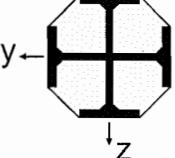
Cross-section	Limits	Axis of buckling	Buckling curve	Member imperfection
concrete encased section 		y-y	b	$L/200$
		z-z	c	$L/150$
partially concrete encased section 		y-y	b	$L/200$
		z-z	c	$L/150$
circular and rectangular hollow steel section 	$\rho_s \leq 3\%$	any	a	$L/300$
	$3\% < \rho_s \leq 6\%$	any	b	$L/200$
circular hollow steel sections with additional I-section 		y-y	b	$L/200$
		z-z	b	$L/200$
partially concrete encased section with crossed I-sections 		any	b	$L/200$

### 6.7.3.6 Resistance of members in combined compression and uniaxial bending

(1) The following expression based on the interaction curve determined according to 6.7.3.2 (2) - (5) should be satisfied:

$$\frac{M_{Ed}}{M_{pl,N,Rd}} = \frac{M_{Ed}}{\mu_d M_{pl,Rd}} \leq \alpha_M \quad (6.45)$$

where:

$M_{Ed}$  is the greatest of the end moments and the maximum bending moment within the column length, calculated according to 6.7.3.4, including imperfections and second order effects if necessary;

$M_{pl,N,Rd}$  is the plastic bending resistance taking into account the normal force  $N_{Ed}$ , given by  $\mu_d M_{pl,Rd}$ , see Figure 6.18;

$M_{pl,Rd}$  is the plastic bending resistance, given by point B in Figure 6.19.

For steel grades between S235 and S355 inclusive, the coefficient  $\alpha_M$  should be taken as 0.9 and for steel grades S420 and S460 as 0.8.

(2) The value  $\mu_d = \mu_{dy}$  or  $\mu_{dz}$ , see Figure 6.20, refers to the design plastic resistance moment  $M_{pl,Rd}$  for the plane of bending being considered. Values  $\mu_d$  greater than 1.0 should only be used where the bending moment  $M_{Ed}$  depends directly on the action of the normal force  $N_{Ed}$ , for example where the moment  $M_{Ed}$  results from an eccentricity of the normal force  $N_{Ed}$ . Otherwise an additional verification is necessary in accordance with clause 6.7.1 (7).

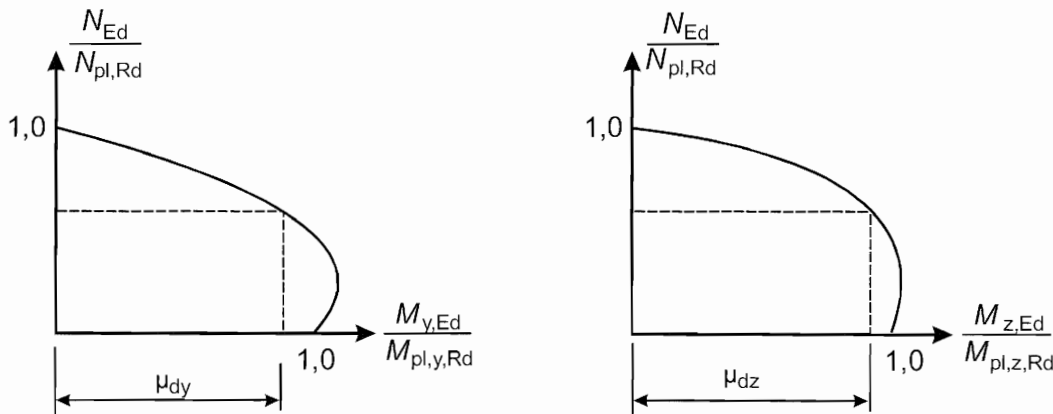

Figure 6.20: Design for compression and biaxial bending

### 6.7.3.7 Combined compression and biaxial bending

(1) For composite columns and compression members with biaxial bending the values  $\mu_{dy}$  and  $\mu_{dz}$  in Figure 6.20 may be calculated according to 6.7.3.6 separately for each axis. Imperfections should be considered only in the plane in which failure is expected to occur. If it is not evident which plane is the more critical, checks should be made for both planes.



(2) For combined compression and biaxial bending the following conditions should be satisfied for the stability check within the column length and for the check at the end:

$$\frac{M_{y,Ed}}{\mu_{dy} M_{pl,y,Rd}} \leq \alpha_{M,y} \qquad \frac{M_{z,Ed}}{\mu_{dz} M_{pl,z,Rd}} \leq \alpha_{M,z} \qquad (6.46)$$

$$\frac{M_{y,Ed}}{\mu_{dy} M_{pl,y,Rd}} + \frac{M_{z,Ed}}{\mu_{dz} M_{pl,z,Rd}} \leq 1.0 \qquad (6.47)$$

where:

- $M_{pl,y,Rd}$  and  $M_{pl,z,Rd}$  are the plastic bending resistances of the relevant plane of bending;
- $M_{y,Ed}$  and  $M_{z,Ed}$  are the design bending moments including second-order effects and imperfections according to 6.7.3.4;
- $\mu_{dy}$  and  $\mu_{dz}$  are defined in 6.7.3.6;
- $\alpha_M = \alpha_{M,y}$  and  $\alpha_M = \alpha_{M,z}$  are given in 6.7.3.6(1).

## 6.7.4 Shear connection and load introduction

### 6.7.4.1 General

(1)P Provision shall be made in regions of load introduction for internal forces and moments applied from members connected to the ends and for loads applied within the length to be distributed between the steel and concrete components, considering the shear resistance at the interface between steel and concrete. A clearly defined load path shall be provided that does not involve an amount of slip at this interface that would invalidate the assumptions made in design.

(2)P Where composite columns and compression members are subjected to significant transverse shear, as for example by local transverse loads and by end moments, provision shall be made for the transfer of the corresponding longitudinal shear stress at the interface between steel and concrete.

(3) For axially loaded columns and compression members, longitudinal shear outside the areas of load introduction need not be considered.

### 6.7.4.2 Load introduction

(1) Shear connectors should be provided in the load introduction area and in areas with change of cross section, if the design shear strength  $\tau_{Rd}$ , see 6.7.4.3, is exceeded at the interface between steel and concrete. The shear forces should be determined from the change of sectional forces of the steel or reinforced concrete section within the introduction length. If the loads are introduced into the concrete cross section only, the values resulting from an elastic analysis considering creep and shrinkage should be taken into account. Otherwise, the forces at the interface should be determined by elastic theory or plastic theory, to determine the more severe case.

(2) In absence of a more accurate method, the introduction length should not exceed  $2d$  or  $L/3$ , where  $d$  is the minimum transverse dimension of the column and  $L$  is the column length.

(3) For composite columns and compression members no shear connection need be provided for load introduction by endplates if the full interface between the concrete section and endplate is permanently in compression, taking account of creep and shrinkage. Otherwise the load introduction should be verified according to (5). For concrete filled tubes of circular cross-section the effect caused by the confinement may be taken into account if the conditions given in 6.7.3.2(6) are satisfied using the values  $\eta_a$  and  $\eta_c$  for  $\bar{\lambda}$  equal to zero.

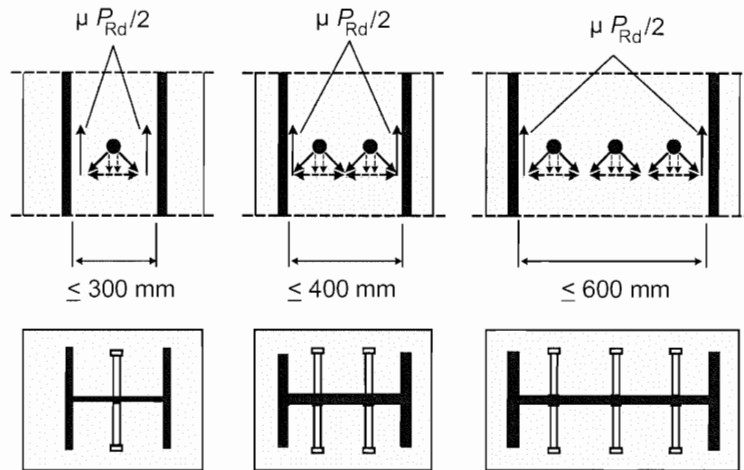

Figure 6.21: Additional frictional forces in composite columns by use of headed studs

(4) Where stud connectors are attached to the web of a fully or partially concrete encased steel I-section or a similar section, account may be taken of the frictional forces that develop from the prevention of lateral expansion of the concrete by the adjacent steel flanges. This resistance may be added to the calculated resistance of the shear connectors. The additional resistance may be assumed to be  $\mu P_{Rd}/2$  on each flange and each horizontal row of studs, as shown in Figure 6.21, where  $\mu$  is the relevant coefficient of friction that may be assumed. For steel sections without painting,  $\mu$  may be taken as 0.5.  $P_{Rd}$  is the resistance of a single stud in accordance with 6.6.3.1. In absence of better information from tests, the clear distance between the flanges should not exceed the values given in Figure 6.21.

(5) If the cross-section is partially loaded (as, for example, Figure 6.22A), the loads may be distributed with a ratio of 1:2.5 over the thickness  $t_c$  of the end plate. The concrete stresses should then be limited in the area of the effective load introduction, for concrete filled hollow sections in accordance with (6) and for all other types of cross-sections in accordance with EN 1992-1-1: 2004, 6.7.

(6) If the concrete in a filled circular hollow section or a square hollow section is only partially loaded, for example by gusset plates through the profile or by stiffeners as shown in Figure 6.22, the local design strength of concrete,  $\sigma_{c,Rd}$  under the gusset plate or stiffener resulting from the sectional forces of the concrete section should be determined by:

$$\sigma_{c,Rd} = f_{cd} \left( 1 + \eta_{cL} \frac{t f_y}{a f_{ck}} \right) \sqrt{\frac{A_c}{A_1}} \leq \frac{A_c f_{cd}}{A_1} \leq f_{yd} \quad (6.48)$$

where:

- $t$  is the wall thickness of the steel tube;
- $a$  is the diameter of the tube or the width of the square section;
- $A_c$  is the cross sectional area of the concrete section of the column;
- $A_1$  is the loaded area under the gusset plate, see Figure 6.22;

$\eta_{cL} = 4.9$  for circular steel tubes and 3.5 for square sections.

The ratio  $A_c/A_1$  should not exceed the value 20. Welds between the gusset plate and the steel hollow sections should be designed according to EN1993-1-8: 2005, Section 4.

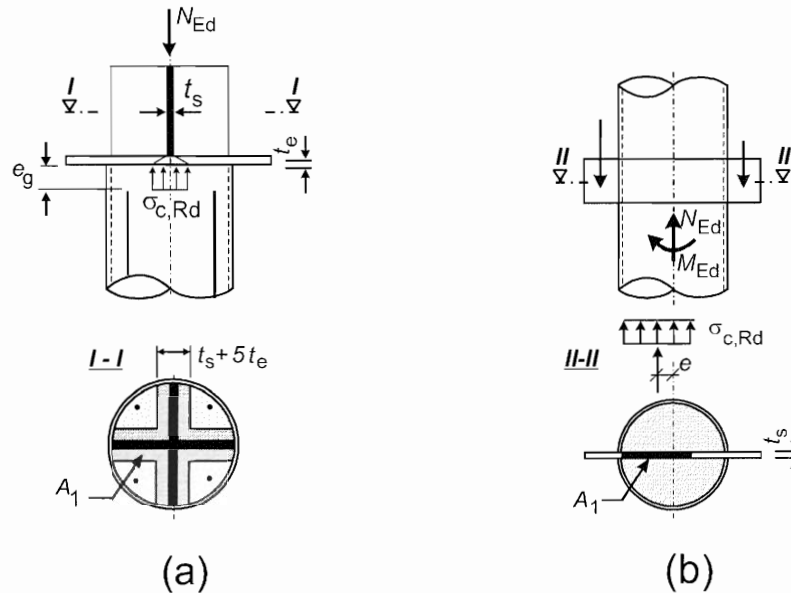
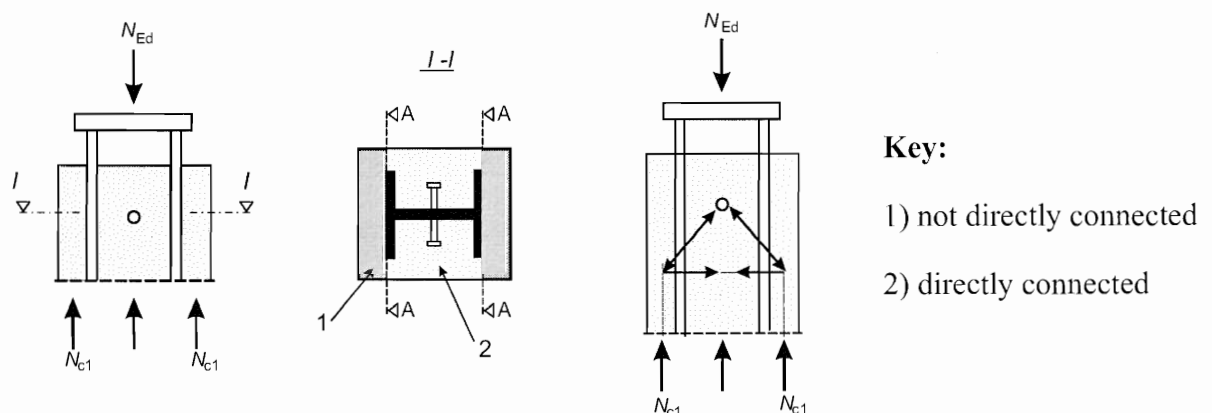

**Figure 6.22: Partially loaded circular concrete filled hollow section**

(7) For concrete filled circular hollow sections, longitudinal reinforcement may be taken into account for the resistance of the column, even where the reinforcement is not welded to the end plates or in direct contact with the endplates provided that:

- verification for fatigue is not required;
- the gap  $e_g$  between the reinforcement and the end plate does not exceed 30 mm, see Figure 6.22A.

(8) Transverse reinforcement should be in accordance with EN 1992-1-1; 2004, 9.5.3. In case of partially encased steel sections, concrete should be held in place by transverse reinforcement arranged in accordance with Figure 6.10 of EN 1994-1-1: 2004.



**Figure 6.23: Directly and not directly connected concrete areas for the design of transverse reinforcement**

(9) In the case of load introduction through only the steel section or the concrete section, for fully encased steel sections the transverse reinforcement should be designed for the longitudinal shear that results from the transmission of normal force ( $N_{c1}$  in Figure 6.23) from the parts of concrete directly connected by shear connectors into the parts of the concrete without direct shear connection (see Figure 6.23, section A-A; the hatched area outside the flanges of Figure 6.23 should be considered as not directly connected). The design and arrangement of transverse reinforcement should be based on a truss model assuming an angle of  $45^\circ$  between concrete compression struts and the member axis.

#### 6.7.4.3 Longitudinal shear outside the areas of load introduction

(1) Outside the area of load introduction, longitudinal shear at the interface between concrete and steel should be verified where it is caused by transverse loads and /or end moments. Shear connectors should be provided, based on the distribution of the design value of longitudinal shear, where this exceeds the design shear strength  $\tau_{Rd}$ .

(2) In absence of a more accurate method, elastic analysis, considering long term effects and cracking of concrete, may be used to determine the longitudinal shear at the interface.

(3) Provided that the surface of the steel section in contact with the concrete is unpainted and free from oil, grease and loose scale or rust, the values given in Table 6.6 may be assumed for  $\tau_{Rd}$ .

**Table 6.6: Design shear strength  $\tau_{Rd}$**

Type of cross section	$\tau_{Rd}$ (N/mm <sup>2</sup> )
Completely concrete encased steel sections	0.30
Concrete filled circular hollow sections	0.55
Concrete filled rectangular hollow sections	0.40
Flanges of partially encased sections	0.20
Webs of partially encased sections	0.00

(4) The value of  $\tau_{Rd}$  given in Table 6.6 for completely concrete encased steel sections applies to sections with a minimum concrete cover of 40mm and transverse and longitudinal reinforcement in accordance with 6.7.5.2. For greater concrete cover and adequate reinforcement, higher values of  $\tau_{Rd}$  may be used. Unless verified by tests, for completely encased sections the increased value  $\beta_c \tau_{Rd}$  may be used, with  $\beta_c$  given by:

$$\beta_c = 1 + 0.02 c_z \left( 1 - \frac{c_{z,\min}}{c_z} \right) \leq 2.5 \quad (6.49)$$

where:

- $c_z$  is the nominal value of concrete cover in mm, see Figure 6.17a;
- $c_{z,\min}$  = 40 mm is the minimum concrete cover.

(5) Unless otherwise verified, for partially encased I-sections with transverse shear due to bending about the weak axis due to lateral loading or end moments, shear connectors should always be provided. If the resistance to transverse shear is not be taken as only the resistance of the structural steel, then the required transverse reinforcement for the shear force  $V_{c,Ed}$  according to 6.7.3.2(4) should be welded to the web of the steel section or should pass through the web of the steel section.

## 6.7.5 Detailing Provisions

### 6.7.5.1 Concrete cover of steel profiles and reinforcement

(1)P For fully encased steel sections at least a minimum cover of reinforced concrete shall be provided to ensure the safe transmission of bond forces, the protection of the steel against corrosion and spalling of concrete.

(2) The concrete cover to a flange of a fully encased steel section should be not less than 40 mm, nor less than one-sixth of the breadth  $b$  of the flange.

(3) For cover of reinforcement in bridges see Section 4.

### 6.7.5.2 Longitudinal and transverse reinforcement

(1) The longitudinal reinforcement in concrete-encased columns which is allowed for in the resistance of the cross-section should be not less than 0,3% of the cross-section of the concrete. In concrete filled hollow sections normally no longitudinal reinforcement is necessary, if design for fire resistance is not required.

(2) The transverse and longitudinal reinforcement in fully or partially concrete encased columns should be designed and detailed in accordance with EN 1992-1-1: 2004, 9.5.

(3) The clear distance between longitudinal reinforcing bars and the structural steel section may be smaller that required by (2), even zero. In this case, for bond the effective perimeter  $c$  of the reinforcing bar should be taken as half or one quarter of its perimeter, as shown in Figure 6.24 at (a) and (b) respectively.

(4) For fully or partially encased members, where environmental conditions are class X0 according to EN 1992-1-1: 2004, Table 4.1, and longitudinal reinforcement is neglected in design, a minimum longitudinal reinforcement of diameter 8 mm and 250 mm spacing and a transverse reinforcement of diameter 6 mm and 200 mm spacing should be provided. Alternatively welded mesh reinforcement of diameter 4 mm may be used.

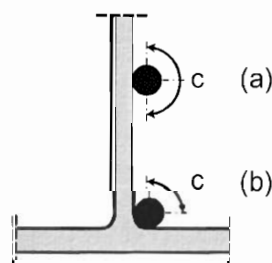

Figure 6.24: Effective perimeter  $c$  of a reinforcing bar

## 6.8 Fatigue

### 6.8.1 General

(1)P The resistance of composite structures to fatigue shall be verified where the structures are subjected to repeated fluctuations of stresses.

(2)P Design for the limit state of fatigue shall ensure, with an acceptable level of probability, that during its entire design life, the structure is unlikely to fail by fatigue or to require repair of damage caused by fatigue.

(3) For headed stud shear connectors in bridges, under characteristic combination of actions the maximum longitudinal shear force per connector should not exceed  $k_s P_{Rd}$  where  $P_{Rd}$  is determined according to 6.6.3.1.

**NOTE:** The factor  $k_s$  may be given in the National Annex. The recommended value is  $k_s=0,75$ .

(4) For structural steel, no fatigue assessment is required where 9.1.1(2) of EN 1993-2 applies.

(5) For concrete and reinforcement, no fatigue assessment is required when EN 1992-2, 6.8.4 (107) or the exceptions listed in 6.8.1(102) of EN 1992-2 apply.

### 6.8.2 Partial factors for fatigue assessment of bridges

(1) Partial factors  $\gamma_{Mf}$  for fatigue strength are given in EN 1993-2, 9.3 for steel elements and in EN 1992-1-1; 2004, 2.4.2.4 for concrete and reinforcement. For headed studs in shear, a partial factor  $\gamma_{Mf,s}$  should be applied.

(2) Partial factors for fatigue loading  $\gamma_{Ff}$  should be applied.

**NOTE:** Partial factors  $\gamma_{Ff}$  are given in Notes in EN 1993-2, 9.3 (1).

### 6.8.3 Fatigue strength

(1) The fatigue strength for structural steel and for welds should be taken from EN 1993-1-9: 2005, 7.

(2) The fatigue strength of reinforcing steel and pre-stressing steel should be taken from EN 1992-1-1: 2004. For concrete EN 1992-1-1: 2004, 6.8.5 applies.

(3) The fatigue strength curve of an automatically welded headed stud in accordance with 6.6.3.1 is shown in Fig. 6.25 and given for normal weight concrete by:

$$(\Delta\tau_R)^m N_R = (\Delta\tau_C)^m N_C \quad (6.50)$$

where:

$\Delta\tau_R$  is the fatigue shear strength related to the cross-sectional area of the shank of the stud, using the nominal diameter  $d$  of the shank;

$\Delta\tau_C$  is the reference value at  $N_C = 2 \times 10^6$  cycles with  $\Delta\tau_C$  equal to  $90 \text{ N/mm}^2$ ;

$m$  is the slope of the fatigue strength curve with the value  $m = 8$ ;

$N_R$  is the number of stress-range cycles.

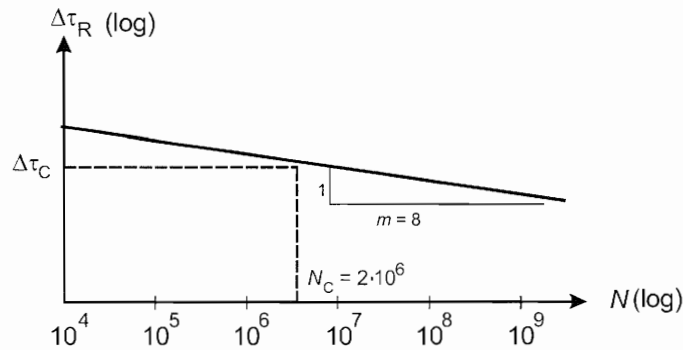

**Figure 6.25: Fatigue strength curve for headed studs in solid slabs**

(4) For studs in lightweight concrete with a density class according to EN 1992-1-1: 2004, 11, the fatigue strength should be determined in accordance with (3) but with  $\Delta\tau_R$  replaced by  $\eta_E\Delta\tau_R$  and  $\Delta\tau_C$  replaced by  $\eta_E\Delta\tau_C$ , where  $\eta_E$  is given in EN 1992-1-1: 2004, 11.3.2.

#### 6.8.4 Internal forces and fatigue loadings

(1) Internal forces and moments should be determined by elastic global analysis of the structure in accordance with 5.4.1 and 5.4.2 and for the combination of actions given in EN 1992-1-1: 2004, 6.8.3.

(2) The maximum and minimum internal bending moments and/or internal forces resulting from the load combination according to (1) are defined as  $M_{Ed,max,f}$  and  $M_{Ed,min,f}$ .

(3) Fatigue loading should be obtained from EN 1991-2: 2003. Where no fatigue loading is specified, Annex A.1 of EN 1993-1-9: 2005 may be used.

(4) For road bridges simplified methods according to EN 1992-2 and EN 1993-2, based on Fatigue Load Model 3 of EN 1991-2: 2003, 4.6 may be used for verifications of fatigue resistance.

(5) For road bridges prestressed by tendons and/or imposed deformations, the factored load model according to EN 1992-2, NN 2.1 should be used for the verification of reinforcement and tendons.

(6) For railway bridges the characteristic values for load model 71 according to EN 1991-2: 2003 should be used.

#### 6.8.5 Stresses

##### 6.8.5.1 General

(1) The calculation of stresses should be based on 7.2.1.

(2)P For the determination of stresses in cracked regions the effect of tension stiffening of concrete on the stresses in reinforcement shall be taken into account.

(3) Unless verified by a more accurate method, the effect of tension stiffening on the stresses in reinforcement may be taken into account according to 6.8.5.4.

(4) Unless a more accurate method is used, for the determination of stresses in structural steel the effect of tension stiffening may be neglected.

(5) The effect of tension stiffening on the stresses in prestressing steel should be taken into account. Clause 6.8.5.6 may be used.

### 6.8.5.2 Concrete

(1) For the determination of stresses in concrete elements EN 1992-1-1: 2004, 6.8 applies.

### 6.8.5.3 Structural steel

(1) Where the bending moments  $M_{Ed,max,f}$  and  $M_{Ed,min,f}$  cause tensile stresses in the concrete slab, the stresses in structural steel for these bending moments may be determined based on the second moment of area  $I_2$  according to 1.5.2.12.

(2) Where  $M_{Ed,min,f}$  and  $M_{Ed,max,f}$  or only  $M_{Ed,min,f}$  cause compression in the concrete slab, the stresses in structural steel for these bending moments should be determined with the cross-section properties of the un-cracked section.

### 6.8.5.4 Reinforcement

(1) Where the bending moment  $M_{Ed,max,f}$  causes tensile stresses in the concrete slab and where no more accurate method is used, the effects of tension stiffening of concrete on the stress  $\sigma_{s,max,f}$  in reinforcement due to  $M_{Ed,max,f}$  should be determined from the equations (7.4) to (7.6) in 7.4.3 (3). In equation (7.5) in 7.4.3(3), a factor 0.2 should be used, in place of the factor 0.4.

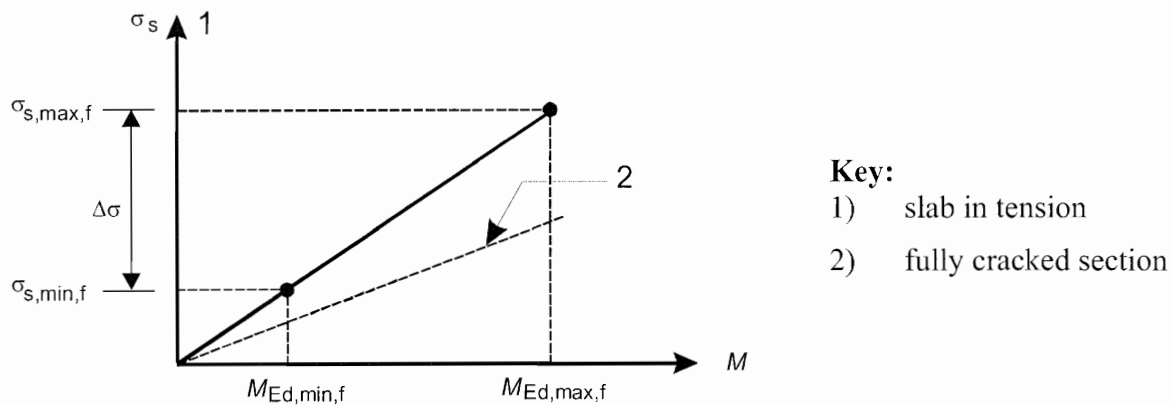

**Figure 6.26: Determination of the stresses  $\sigma_{s,max,f}$  and  $\sigma_{s,min,f}$  in cracked regions**

(2) Where also the bending moment  $M_{Ed,min,f}$  causes tensile stress in the concrete slab the stress range  $\Delta\sigma$  is given by Figure 6.26 and the stress  $\sigma_{s,min,f}$  in reinforcement due to  $M_{Ed,min,f}$  can be determined from:

$$\sigma_{s,min,f} = \sigma_{s,max,f} \frac{M_{Ed,min,f}}{M_{Ed,max,f}} \quad (6.51)$$



(3) Where  $M_{Ed,min,f}$  and  $M_{Ed,max,f}$  or only  $M_{Ed,min,f}$  cause compression in the concrete slab, the stresses in reinforcement for these bending moments should be determined with the cross-section properties of the un-cracked section.

#### 6.8.5.5 Shear Connection

(1)P The longitudinal shear per unit length shall be calculated by elastic analysis.

(2) In members where cracking of concrete occurs the effects of tension stiffening should be taken into account by an appropriate model. For simplification, the longitudinal shear forces at the interface between structural steel and concrete may be determined by using the properties of the un-cracked section.

#### 6.8.5.6 Stresses in reinforcement and prestressing steel in members prestressed by bonded tendons

(1)P For members with bonded tendons the different bond behaviour of reinforcement and tendons shall be taken into account for the determination of stresses in reinforcement and tendons

(2) Stresses should be determined according to 6.8.5.4 but with  $\sigma_{s,max,f}$  determined according to 7.4.3 (4).

#### 6.8.6 Stress ranges

##### 6.8.6.1 Structural steel and reinforcement

(1) The stress ranges should be determined from the stresses determined in accordance with 6.8.5

(2) Where the verification for fatigue is based on damage equivalent stress ranges, in general a range  $\Delta\sigma_E$  should be determined from:

$$\Delta\sigma_E = \lambda \phi \left| \sigma_{max,f} - \sigma_{min,f} \right| \quad (6.52)$$

where:

- $\sigma_{max,f}$  and  $\sigma_{min,f}$  are the maximum and minimum stresses due to 6.8.4 and 6.8.5;
- $\lambda$  is a damage equivalent factor;
- $\phi$  is a damage equivalent impact factor.

(3) Where a member is subjected to combined global and local effects the separate effects should be considered. Unless a more precise method is used the equivalent constant amplitude stress due to global effects and local effects should be combined using:

$$\Delta\sigma_E = \lambda_{glob} \phi_{glob} \Delta\sigma_{E,glob} + \lambda_{loc} \phi_{loc} \Delta\sigma_{E,loc} \quad (6.53)$$

in which subscripts “glob” and “loc” refer to global and local effects, respectively.

(4) The damage equivalent factor  $\lambda$  depends on the loading spectrum and the slope of the fatigue strength curve.

(5) The factor  $\lambda$  for structural steel elements is given in EN 1993-2, 9.5.2 for road bridges and in EN1993-2, 9.5.3 for railway bridges.

**NOTE:** Factors  $\lambda = \lambda_s$  for reinforcement and prestressing steel are given in EN 1992-2, NN.2 (Informative) for road bridges and NN.3 (Informative) for railway bridges.

(6) For railway bridges the damage equivalent impact factor  $\phi$  is defined in EN 1991-2: 2003, 6.4.5.

(7) For road bridges the damage equivalent impact factor may be taken as equal to 1.0.

### 6.8.6.2 Shear connection

(1) For verification of stud shear connectors based on nominal stress ranges the equivalent constant range of shear stress  $\Delta\tau_{E,2}$  for 2 million cycles is given by:

$$\Delta\tau_{E,2} = \lambda_v \Delta\tau \quad (6.54)$$

where:

$\lambda_v$  is the damage equivalent factor depending on the spectra and the slope  $m$  of the fatigue strength curve;

$\Delta\tau$  is the range of shear stress due to fatigue loading, related to the cross-sectional area of the shank of the stud using the nominal diameter  $d$  of the shank.

(2) The equivalent constant amplitude shear stress range in welds of other types of shear connection should be calculated in accordance with EN 1993-1-9: 2005, 6.

(3) For bridges the damage equivalent factor  $\lambda_v$  for headed studs in shear should be determined from  $\lambda_v = \lambda_{v,1} \lambda_{v,2} \lambda_{v,3} \lambda_{v,4}$  where the factors  $\lambda_{v,1}$  to  $\lambda_{v,4}$  are defined in (4) and (5).

(4) For road bridges of span up to 100 m the factor  $\lambda_{v,1}=1,55$  should be used. The factors  $\lambda_{v,2}$  to  $\lambda_{v,4}$  should be determined in accordance with 9.5.2 (3) to (6) of EN 1993-2 but using exponents 8 and 1/8 in place of those given, to allow for the relevant slope  $m = 8$  of the fatigue strength curve for headed studs, given in 6.8.3.

(5) For railway bridges the factor  $\lambda_{v,1}$  should be taken from Figure 6.27.

**NOTE:** The factors  $\lambda_{v,2}$  to  $\lambda_{v,4}$  may be determined in accordance with EN 1992-2, NN3.1(104) to (106), but using the exponent  $m = 8$  for headed studs instead of the exponent  $k_2$ .

## 6.8.7 Fatigue assessment based on nominal stress ranges

### 6.8.7.1 Structural steel, reinforcement and concrete

(1) The fatigue assessment for reinforcement should follow EN 1992-1-1: 2004, 6.8.5 or 6.8.6.

(2) The verification for concrete in compression should follow EN 1992-2, 6.8.7.

(3) For bridges the fatigue assessment for structural steel should comply with Section 9 of EN 1993-2.

(4) The fatigue assessment for prestressing steel should comply with EN 1992-1-1: 2004, 6.8.5.

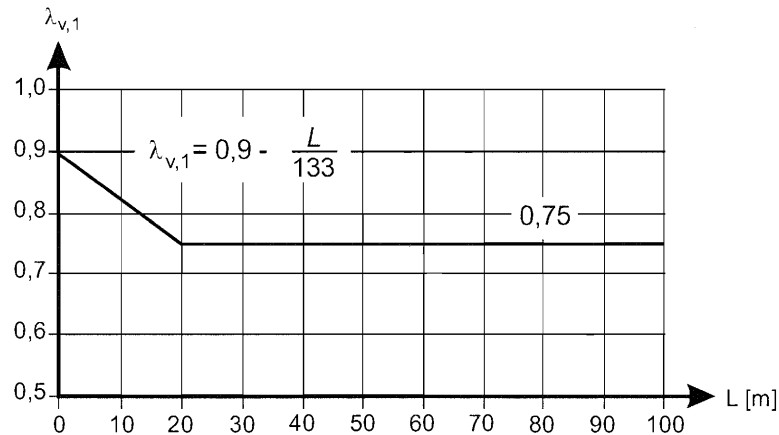

**Figure 6.27: Values  $\lambda_{v,1}$  as a function of the span length for standard and heavy traffic for load model 71 according to EN 1991-2: 2003**

### 6.8.7.2 Shear connection

(1) For stud connectors welded to a steel flange that is always in compression under the relevant combination of actions (see 6.8.4 (1)), the fatigue assessment should be made by checking the criterion:

$$\gamma_{Ff} \Delta\tau_{E,2} \leq \Delta\tau_c / \gamma_{Mf,s} \quad (6.55)$$

where:

$\Delta\tau_{E,2}$  is defined in 6.8.6.2(1);

$\Delta\tau_c$  is the reference value of fatigue strength at 2 million cycles determined in accordance with 6.8.3.

The stress range  $\Delta\tau$  in the stud should be determined with the cross-sectional area of the shank of the stud using the nominal diameter  $d$  of the shank.

(2) Where the maximum stress in the steel flange to which stud connectors are welded is tensile under the relevant combination, the interaction at any cross-section between shear stress range  $\Delta\tau_E$  in the weld of stud connectors and the normal stress range  $\Delta\sigma_E$  in the steel flange should be verified using the following interaction expressions.

$$\frac{\gamma_{Ff} \Delta\sigma_{E,2}}{\Delta\sigma_c / \gamma_{Mf}} + \frac{\gamma_{Ff} \Delta\tau_{E,2}}{\Delta\tau_c / \gamma_{Mf,s}} \leq 1.3 \quad (6.56)$$

$$\frac{\gamma_{Ff} \Delta\sigma_{E,2}}{\Delta\sigma_c / \gamma_{Mf}} \leq 1.0 \quad \frac{\gamma_{Ff} \Delta\tau_{E,2}}{\Delta\tau_c / \gamma_{Mf,s}} \leq 1.0 \quad (6.57)$$

where:

$\Delta\sigma_{E,2}$  is the stress range in the flange determined in accordance with 6.8.6.1;

$\Delta\sigma_c$  is the reference value of fatigue strength given in EN1993-1-9; 2005, 7, by applying category 80

and the stress ranges  $\Delta\tau_{E,2}$  and  $\Delta\tau_c$  are defined in (1).

Expression (6.56) should be checked for the maximum value of  $\Delta\sigma_{E,2}$  and the corresponding value  $\Delta\tau_{E,2}$ , as well as for the combination of the maximum value of  $\Delta\tau_{E,2}$  and the corresponding value of  $\Delta\sigma_{E,2}$ . Unless taking into account the effect of tension stiffening of concrete by more accurate methods, the interaction criterion should be verified with the corresponding stress ranges determined with both cracked and un-cracked cross-sectional properties.

## 6.9 Tension members in composite bridges

(1) An isolated reinforced concrete tension member according to 5.4.2.8 (1) (a) should be designed in accordance with Sections 6 and 9 of EN 1992-2. For prestressing by tendons the effect of different bond behaviour of prestressing and reinforcing steel should be taken into account according to 6.8.2 of EN 1992-1-1: 2004.

(2) For tension members in half-through or through bridges and bowstring arch bridges where the tension member is simultaneously acting as a deck and is subjected to combined global and local effects, the design shear resistance for local vertical shear and for punching shear due to permanent loads and traffic loads should be verified. Unless a more precise method is used, the verification should be according to 6.2 and 6.4 of EN 1992-1-1: 2004 and 6.2.2.5 (3) by taking into account the normal force of the reinforced concrete element according to 5.4.2.8(3) and (6).

(3) At the ends of a concrete part of a composite tension member, for the introduction of the normal force, a concentrated group of shear connectors designed according to 6.6 should be provided. The shear connection should be able to transfer the design value of the normal force of the concrete tension element over a length  $1.5 b$ , where  $b$  is the larger of the outstand of the concrete member and half the distance between adjacent steel elements. Where the shear connectors are verified for a normal force determined by 5.4.2.8(6), equation (5.6-3) should be used.

(4)P Provision shall be made for internal forces and moments from members connected to the ends of a composite tension member to be distributed between the structural steel and reinforced concrete elements.

(5) For composite tension members subject to tension and bending a shear connection should be provided according to 6.6.

(6) For composite tension members such as diagonals in trusses, the introduction length for the normal force should not be assumed in calculation to exceed twice the minimum transverse dimension of the member.

## Section 7 Serviceability limit states

### 7.1 General

(1)P A structure with composite members shall be designed and constructed such that all relevant serviceability limit states are satisfied according to the Principles of 3.4 of EN 1990: 2002.

(2) The verification of serviceability limit states should be based on the criteria given in EN 1990: 2002, 3.4(3).

(3) The composite bridge or specific parts of it should be classified into environmental classes according to EN 1992-2, 4.

(4) For bridges or parts of bridges, verifications for serviceability limit states should be performed for both the construction phases and for the persistent situations.

(5) Where relevant, requirements and criteria given in A2.4 of Annex A2 of EN 1990: 2002 should be taken into account.

(6) Serviceability limit states for composite plates should be verified in accordance with Section 9.

## **7.2 Stresses**

### **7.2.1 General**

(1)P Calculation of stresses for beams at the serviceability limit state shall take into account the following effects, where relevant:

- shear lag;
- creep and shrinkage of concrete;
- cracking of concrete and tension stiffening of concrete;
- sequence of construction;
- increased flexibility resulting from significant incomplete interaction due to slip of shear connection;
- inelastic behaviour of steel and reinforcement, if any;
- torsional and distortional warping, if any.

(2) Shear lag may be taken into account according to 5.4.1.2.

(3) Unless a more accurate method is used, effects of creep and shrinkage may be taken into account by use of modular ratios according to 5.4.2.2.

(4) In cracked sections the primary effects of shrinkage may be neglected when verifying stresses.

(5)P In section analysis the tensile strength of concrete shall be neglected.

(6) The influence of tension stiffening of concrete between cracks on stresses in reinforcement and pre-stressing steel should be taken into account. Unless more accurate methods are used, the stresses in reinforcement should be determined according to 7.4.3.

(7) The influences of tension stiffening on stresses in structural steel may be neglected.

(8) Stresses in the concrete slab and its reinforcement caused by simultaneous global and local actions should be added.

### **7.2.2 Stress limitation for bridges**

(1)P Excessive creep and microcracking shall be avoided by limiting the compressive stress in concrete.

- (2) Stress limitation for concrete to the value  $k_i f_{ck}$  should be in accordance with  $\boxed{\text{AC1}}$  EN 1992-1-1: 2004  $\boxed{\text{AC1}}$ , 7.2 as modified by EN 1992-2.
- (3)P The stress in reinforcing steel and in prestressing tendons shall be such that inelastic strains in the steel are avoided.
- (4) Under the characteristic combination of actions the stresses should be limited to  $k_i f_{sk}$  in reinforcing steel and to  $k_5 f_{pk}$  in tendons, where the values  $k_i$  and  $k_5$  are given in EN 1992-1-1: 2004, 7.2(5).
- (5) The stresses in structural steel should be in accordance with EN 1993-2, 7.3.
- (6) For serviceability limit states the longitudinal shear force per connector should be limited according to 6.8.1 (3).

### 7.2.3 Web breathing

- (1) The slenderness of unstiffened or stiffened web plates of composite girders should be limited according to 7.4 of EN 1993-2.

## 7.3 Deformations in bridges

### 7.3.1 Deflections

- (1) For the limit state of deformation EN 1990: 2002, A2.4 of Annex A2 and EN 1993-2, 7.5 to 7.8 and 7.12 apply, where relevant.
- (2) Deflections should be calculated using elastic analysis in accordance with Section 5.
- (3) Deformations during construction should be controlled such that the concrete is not impaired during its placing and setting by uncontrolled displacements and the required long-term geometry is achieved.

### 7.3.2 Vibrations

- (1) For the limit state of vibration EN 1990: 2002, A2.4 of Annex A2, EN 1991-2: 2003, 5.7 and 6.4  $\boxed{\text{AC1}}$  and EN 1993-2, 7.7 to 7.10 apply where relevant.  $\boxed{\text{AC1}}$

## 7.4 Cracking of concrete

### 7.4.1 General

- (1) For the limitation of crack width in bridges, the general considerations of EN 1992-1-1: 2004, 7.3.1 as modified in EN 1992-2 apply to composite structures. The limitation of crack width depends on the exposure classes according to EN 1992-2, 4.

(2) An estimation of crack width can be obtained from EN 1992-1-1: 2004, 7.3.4, where the stress  $\sigma_s$  should be calculated by taking into account the effects of tension stiffening. Unless a more precise method is used,  $\sigma_s$  may be determined according to 7.4.3(3).

(3) As a simplified and conservative alternative, crack width limitation to acceptable width can be achieved by ensuring a minimum reinforcement defined in 7.4.2, and bar spacing or diameters not exceeding the limits defined in 7.4.3.

(4) Application rules for the limitation of crack widths to  $w_k$  are given in 7.4.2 and 7.4.3.

**NOTE:** The values of  $w_k$  and the combination of actions may be found in the National Annex. The recommended values for relevant exposure classes are as given (as  $w_{max}$ ) in the Note to EN 1992-2, 7.3.1(105)

(5) Where composite action becomes effective as concrete hardens, effects of heat of hydration of cement and corresponding thermal shrinkage should be taken into account only during the construction stage for the serviceability limit state to define areas where tension is expected.

(6) Unless specific measures are taken to limit the effects of heat of hydration of cement, for simplification a constant temperature difference between the concrete section and the steel section (concrete cooler) should be assumed for the determination of the cracked regions according to 7.4.2 (5) and for limitation of crack width according to 7.4.2 and 7.4.3. For the determination of stresses in concrete the short term modulus should be used.

**NOTE:** The National Annex may give specific measures and a temperature difference. The recommended value for the temperature difference is 20K.

#### 7.4.2 Minimum reinforcement

(1) Unless a more accurate method is used in accordance with EN 1992-1-1: 2004, 7.3.2(1), in all sections without pre-stressing by tendons and subjected to significant tension due to restraint of imposed deformations (e.g. primary and secondary effects of shrinkage), in combination or not with effects of direct loading the required minimum reinforcement area  $A_s$  for the slabs of composite beams is given by:

$$A_s = k_s k_c k f_{ct,eff} A_{ct} / \sigma_s \quad (7.1)$$

where :

$f_{ct,eff}$  is the mean value of the tensile strength of the concrete effective at the time when cracks may first be expected to occur. Values of  $f_{ct,eff}$  may be taken as those for  $f_{ctm}$ , see EN 1992-1-1: 2004, Table 3.1, or as  $f_{lctm}$ , see Table 11.3.1, as appropriate, taking as the class the strength at the time cracking is expected to occur. When the age of the concrete at cracking cannot be established with confidence as being less than 28 days, a minimum tensile strength of 3 N/mm<sup>2</sup> may be adopted;

$k$  is a coefficient which allows for the effect of non-uniform self-equilibrating stresses which may be taken as 0.8;

$k_s$  is a coefficient which allows for the effect of the reduction of the normal force of the concrete slab due to initial cracking and local slip of the shear connection, which may be taken as 0.9;

$k_c$  is a coefficient which takes account of the stress distribution within the section immediately prior to cracking and is given by:

$$k_c = \frac{1}{1 + h_c / (2z_0)} + 0.3 \leq 1.0 \quad (7.2)$$

$h_c$  is the thickness of the concrete flange, excluding any haunch or ribs;

$z_0$  is the vertical distance between the centroids of the un-cracked concrete flange and the un-cracked composite section, calculated using the modular ratio  $n_0$  for short-term loading;

$\sigma_s$  is the maximum stress permitted in the reinforcement immediately after cracking. This may be taken as its characteristic yield strength  $f_{sk}$ . A lower value, depending on the bar size, may however be needed to satisfy the required crack width limits. This value is given in Table 7.1;

$A_{ct}$  is the area of the tensile zone (caused by direct loading and primary effects of shrinkage) immediately prior to cracking of the cross section. For simplicity the area of the concrete section within the effective width may be used.

**Table 7.1: Maximum bar diameters for high bond bars**

Steel stress $\sigma_s$ (N/mm <sup>2</sup> )	Maximum bar diameter $\phi^*$ (mm) for design crack width $w_k$		
	$w_k=0.4\text{mm}$	$w_k=0.3\text{mm}$	$w_k=0.2\text{mm}$
160	40	32	25
200	32	25	16
240	20	16	12
280	16	12	8
320	12	10	6
360	10	8	5
400	8	6	4
450	6	5	-

(2) The maximum bar diameter for the minimum reinforcement may be modified to a value  $\phi$  given by:

$$\phi = \phi^* f_{ct,eff} / f_{ct,0} \quad (7.3)$$

where:

$\phi^*$  is the maximum bar size given in Table 7.1;

$f_{ct,0}$  is a reference strength of 2.9 N/mm<sup>2</sup>.

(3) At least half of the required minimum reinforcement should be placed between mid-depth of the slab and the face subjected to the greater tensile strain.

(4) For the determination of the minimum reinforcement in concrete flanges with variable depth transverse to the direction of the beam the local depth should be used.

(5) The minimum reinforcement according to (1) and (2) should be placed where the stresses in concrete are tensile under the characteristic combination of actions. For members prestressed by bonded tendons EN 1992-1-1: 2004, 7.3.2 (4) applies.



(6) Where bonded tendons are used, the contribution of bonded tendons to minimum reinforcement may be taken into account in accordance with EN 1992-1-1: 2004, 7.3.2 (3).

### 7.4.3 Control of cracking due to direct loading

(1) Where at least the minimum reinforcement given by 7.4.2 is provided, the limitation of crack widths to acceptable values may generally be achieved by limiting bar spacing or bar diameters. Maximum bar diameter and maximum bar spacing depend on the stress  $\sigma_s$  in the reinforcement and the design crack width. Maximum bar diameters are given in Table 7.1 and maximum bar spacing in Table 7.2.

**Table 7.2 Maximum bar spacing for high bond bars**

Steel stress $\sigma_s$ (N/mm <sup>2</sup> )	Maximum bar spacing (mm) for design crack width $w_k$		
	$w_k=0.4\text{mm}$	$w_k=0.3\text{mm}$	$w_k=0.2\text{mm}$
160	300	300	200
200	300	250	150
240	250	200	100
280	200	150	50
320	150	100	-
360	100	50	-

(2) The internal forces should be determined by elastic analysis in accordance with Section 5 taking into account the effects of cracking of concrete. The stresses in the reinforcement should be determined taking into account effects of tension stiffening of concrete between cracks. Unless a more precise method is used, the stresses may be calculated according to (3).

(3) In composite beams where the concrete slab is assumed to be cracked and not pre-stressed by tendons, stresses in reinforcement increase due to the effects of tension stiffening of concrete between cracks compared with the stresses based on a composite section neglecting concrete. The tensile stress in reinforcement  $\sigma_s$  due to direct loading may be calculated from:

$$\sigma_s = \sigma_{s,0} + \Delta\sigma_s \quad (7.4)$$

with:

$$\Delta\sigma_s = \frac{0.4 f_{ctm}}{\alpha_{st} \rho_s} \quad (7.5)$$

$$\alpha_{st} = \frac{AI}{A_a I_a} \quad (7.6)$$

where:

$\sigma_{s,0}$  is the stress in the reinforcement caused by the internal forces acting on the composite section, calculated neglecting concrete in tension;

$f_{ctm}$  is the mean tensile strength of the concrete, for normal concrete taken as  $f_{ctm}$  from EN 1992-1-1: 2004, Table 3.1 or for lightweight concrete as  $f_{lctm}$  from Table 11.3.1;

$\rho_s$  is the reinforcement ratio, given by  $\rho_s = (A_s / A_{ct})$ ;

$A_{ct}$  is the effective area of the concrete flange within the tensile zone; for simplicity the area of the concrete section within the effective width should be used;

$A_s$  is the total area of all layers of longitudinal reinforcement within the effective area  $A_{ct}$ ;

$A, I$  are area and second moment of area, respectively, of the effective composite section neglecting concrete in tension and profiled sheeting, if any;

$A_a, I_a$  are the corresponding properties of the structural steel section.

(4) Where bonded tendons are used, design should follow EN 1992-1-1, 7.3, where  $\sigma_s$  should be determined taking into account tension stiffening effects.

## 7.5 Filler beam decks

### 7.5.1 General

(1) The action effects for the serviceability limit states should be determined according to paragraphs (1) to (4) and (6) to (8) of 5.4.2.9.

### 7.5.2 Cracking of concrete

(1) The application rules of 7.4.1 should be considered.

(2) For the reinforcing bars in the direction of the steel beams within the whole thickness of the deck, 7.5.3 and 7.5.4 should be applied.

### 7.5.3 Minimum reinforcement

(1) Unless verified by more accurate methods, the minimum longitudinal top reinforcement  $A_{s,min}$  per filler beam should be determined as follows:

$$A_{s,min} \geq 0.01 A_{c,eff} \quad (7.7)$$

where

$A_{c,eff}$  is the effective area of concrete given by  $A_{c,eff} = s_w c_{st} \leq s_w d_{eff}$

$d_{eff}$  is the effective thickness of the concrete given by  $d_{eff} = c + 7.5 \phi_s$

$\phi_s$  is the diameter of the longitudinal reinforcement in [mm] within the range  
 $10\text{mm} \leq \phi_s \leq 16\text{mm}$

$c, c_{st}$  is the concrete cover of the longitudinal reinforcement and the structural steel section (see Figure 6.8)

$s_w$  is defined in Figure 6.8

The bar spacing  $s$  of the longitudinal reinforcement should fulfil the following condition  
 $100 \text{ mm} \leq s \leq 150 \text{ mm}$

### 7.5.4 Control of cracking due to direct loading

(1) Clause 7.4.3 (1) is applicable

(2) The stresses in the reinforcement may be calculated by using the cross-section properties of the cracked composite section with the second moment of area  $I_2$  according to 1.5.2.12.

## **Section 8 Precast concrete slabs in composite bridges**

### **8.1 General**

- (1) This Section 8 deals with reinforced or prestressed precast concrete slabs, used either as full depth flanges of bridge decks or as partial depth slabs acting with in-situ concrete.
- (2) Precast bridge slabs should be designed in accordance with EN 1992 and also for composite action with the steel beam.
- (3) Tolerances of the steel flange and the precast concrete element should be considered in the design.

### **8.2 Actions**

- (1) EN 1991-1-6: 2005 is applicable to precast elements acting as permanent formwork. The requirements are not necessarily sufficient and the requirements of the construction method should also be taken into account.

### **8.3 Design, analysis and detailing of the bridge slab**

- (1) Where it is assumed that the precast slab acts with in-situ concrete, they should be designed as continuous in both the longitudinal and the transverse directions. The joints between slabs should be designed to transmit in-plane forces as well as bending moments and shears. Compression perpendicular to the joint may be assumed to be transmitted by contact pressure if the joint is filled with mortar or glue or if it is shown by tests that the mating surfaces are in sufficiently close contact.
- (2) For the use of stud connectors in groups, see 6.6.5.5(4).
- (3) A stepped distribution of longitudinal shear forces may be used provided that the limitations in 6.6.1.2(1) are observed.

## **8.4 Interface between steel beam and concrete slab**

### **8.4.1 Bedding and tolerances**

- (1) Where precast slabs without bedding are used, any special requirements for the tolerances of the supporting steel work should be specified.

### **8.4.2 Corrosion**

- (1) A steel flange under precast slabs without bedding should have the same corrosion protection as the rest of the steelwork, except that any cosmetic coating applied after erection may be omitted.

### **8.4.3 Shear connection and transverse reinforcement**

- (1) The shear connection and transverse reinforcement should be designed in accordance with the relevant clauses of Section 6 and 7.
- (2) If shear connectors welded to the steel beam project into recesses within slabs or joints between slabs, which are filled with concrete after erection, the detailing and the properties of the concrete (e.g. size of the aggregate) should be such that it can be cast properly. The clear distance between

the shear connectors and the precast element should be sufficient in all directions to allow for full compaction of the infill concrete taking account of tolerances.

(3) If shear connectors are arranged in groups, reinforcement should be provided near each group to prevent premature local failure in either the precast or the insitu concrete.

NOTE: The National Annex may refer to relevant information

## Section 9 Composite plates in bridges

### 9.1 General

(1) This Section 9 is valid for composite plates consisting of a nominally flat plate of structural steel connected to a site cast concrete layer by headed studs for use as a flange in a bridge deck carrying transverse loads as well as in-plane forces, or as a bottom flange in a box girder. Double skin plates or other types of connectors are not covered.

(2) The steel plate should be supported during casting either permanently or by temporary supports in order to limit its deflection to less than 0,05 times the thickness of the concrete layer unless the additional weight of concrete due to the deflection of the plate is taken into account in the design of the steel plate.

(3) The effective width should be determined according to 5.4.1.2, where  $b_0$  should be taken as  $2a_w$  with  $a_w$  as defined in 9.4(4).

(4) For global analysis, 5.1 and 5.4 apply.

### 9.2 Design for local effects

(1) Local effects are bending moments and shears caused by transverse loads on the composite plate acting as a one- or two-way slab. For the purpose of analysis of local action effects the composite plate may be assumed to be elastic and uncracked. A top flange of an I-girder need not be designed as composite in the transverse direction.

(2) The concrete and the steel plate may be assumed to act compositely without slip.

(3) The resistance to bending and vertical shear force may be verified as for a reinforced concrete slab where the steel plate is considered as reinforcement. The design resistance for vertical shear in 6.2.2.5(3) is applicable, where the distance, in longitudinal and transverse direction, between shear connectors does not exceed three times the thickness of the composite plate.

### 9.3 Design for global effects

(1)P The composite plate shall be designed to resist all forces from axial loads and global bending and torsion of all longitudinal girders or cross-girders of which it forms a part.

(2) The design resistance to in-plane compression may be taken as the sum of the design resistances of the concrete and the steel plate within the effective width. Reduction in strength due to second order effects should be considered according to 5.8 of EN 1992-1-1: 2004.

(3) The design resistance for in-plane tension should be taken as the sum of the design resistances of the steel plate and the reinforcement within the effective width.

(4) Interaction with local load effects should be considered for the shear connectors as stated in 9.4(1)P. Otherwise it need not be considered. Connectors designed for shear forces in both the longitudinal and transverse directions should be verified for the vector sum of the simultaneous forces on the connector.

#### 9.4 Design of shear connectors

(1)P Resistance to fatigue and requirements for serviceability limit states shall be verified for the combined local and simultaneous global effect.

(2) The design strength of stud connectors in 6.6.3 and 6.8.3 may be used provided that the concrete slab has bottom reinforcement with area not less than 0.002 times the concrete area in each of two perpendicular directions.

(3) The detailing rules of 6.6.5 are applicable.

(4) For wide girder flanges the distribution of longitudinal shear due to global effects for serviceability and fatigue limit states may be determined as follows in order to account for slip and shear lag. The longitudinal force  $P_{Ed}$  on a connector at distance  $x$  from the nearest web may be taken as

$$P_{Ed} = \frac{v_{L,Ed}}{n_{tot}} \left[ \left( 3.85 \left( \frac{n_w}{n_{tot}} \right)^{-0,17} - 3 \right) \left( 1 - \frac{x}{b} \right)^2 + 0.15 \right] \quad (9.1)$$

where

$v_{L,Ed}$  is the design longitudinal shear per unit length in the concrete slab due to global effects for the web considered, determined using effective widths for shear lag,

$n_{tot}$  is the total number of connectors of the same size per unit length of girder as shown in Figure 9.1, provided that the number of connectors per unit area does not increase with  $x$ ,

$n_w$  is the number of connectors per unit length placed within a distance from the web equal to the larger of  $10t_f$  and 200 mm, where  $t_f$  is the thickness of the steel plate. For these connectors  $x$  should be taken as 0,

$b$  is equal to half the distance between adjacent webs or the distance between the web and the free edge of the flange.

In case of a flange projecting distance  $a_w$  outside the web according to Fig. 9.1, the number of connectors  $n_{tot}$  and  $n_w$  may include connectors placed on this flange. Shear connectors should be concentrated in the region for  $n_w$  according to Fig. 9.1. The spacing of the connectors should fulfill the conditions in (7) to avoid premature local buckling of the plate.

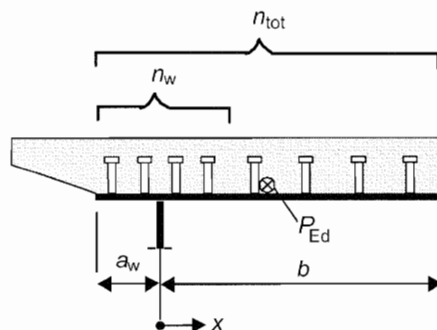

Figure 9.1: Definition of notations in equation (9.1)

(5) A more accurate determination of the distribution of longitudinal shear forces in composite bottom flanges of box sections according to (4) is not required, if the arrangement of the shear connectors is based on the following rules:

- Shear connectors should be concentrated in the corners of the box girder;
- At least 50% of the total amount of shear connectors, which are responsible for the transfer of the longitudinal shear force from  $\boxed{AC_1}$  a web to the bottom concrete flange  $\boxed{AC_1}$  should be attached to the web and within the width  $b_f$  of the steel bottom flange. The width  $b_f$  of the steel bottom flange should be taken as the largest of

$$b_f = 20 t_f, \quad b_f = 0.2 b_{ci} \quad \text{and} \quad b_f = 400 \text{ mm}$$

where  $b_{ci}$  is the effective width of the lower flange according to 5.4.1.2 and  $t_f$  the thickness of the steel bottom flange.

(6) For ultimate limit states it may be assumed that all connectors within the effective width carry the same longitudinal force.

(7) Where restraint from shear connectors is relied upon to prevent local buckling of the steel element of a composite plate in compression, the centre-to-centre spacings of the connectors should not exceed the limits given in Table 9.1.

Table 9.1: Upper limits to spacings of shear connectors in a composite plate in compression

		Class 2	Class 3
Transverse to the direction of compressive stress	outstand flange:	14 $t\varepsilon$	20 $t\varepsilon$
	interior flange:	45 $t\varepsilon$	50 $t\varepsilon$
In the direction of compressive stress	outstand and interior flanges:	22 $t\varepsilon$	25 $t\varepsilon$
$\varepsilon = \sqrt{235 / f_y}$ , with $f_y$ in N/mm <sup>2</sup>		t – thickness of the steel flange	

## Annex C (Informative)

### Headed studs that cause splitting forces in the direction of the slab thickness

#### C.1 Design resistance and detailing

(1) The design shear resistance of a headed stud according to 6.6.3.1, that causes splitting forces in the direction of the slab thickness, see Figure C.1, should be determined for ultimate limit states other than fatigue from equation (C.1), if this leads to a smaller value than that from equations (6.18) and (6.19):

$$P_{Rd,L} = \frac{1.4 k_v (f_{ck} d a'_r)^{0,4} (a/s)^{0,3}}{\gamma_V} \quad [\text{kN}] \quad (\text{C.1})$$

where:

$a'_r$  is the effective edge distance;  $= a_r - c_v - \phi_s / 2 \geq 50 \text{ mm}$ ;

$k_v = 1$  for shear connection in an edge position,

$= 1.14$  for shear connection in a middle position;

$\gamma_V$  is a partial factor;

**NOTE:** See the Note to 6.6.3.1(1) for  $\gamma_V$

$f_{ck}$  is the characteristic cylinder strength of the concrete at the age considered, in  $\text{N/mm}^2$ ;

$d$  is the diameter of the shank of the stud with  $19 \leq d \leq 25 \text{ mm}$ ;

$h$  is the overall height of the headed stud with  $h/d \geq 4$ ;

$a$  is the horizontal spacing of studs with  $110 \leq a \leq 440 \text{ mm}$ ;

$s$  is the spacing of stirrups with both  $a/2 \leq s \leq a$  and  $s/a'_r \leq 3$ ;

$\phi_s$  is the diameter of the stirrups with  $\phi_s \geq 8 \text{ mm}$ ;

$\phi_\ell$  is the diameter of the longitudinal reinforcement with  $\phi_\ell \geq 10 \text{ mm}$ ;

$c_v$  is the vertical concrete cover according to Fig. C.1 in [mm].

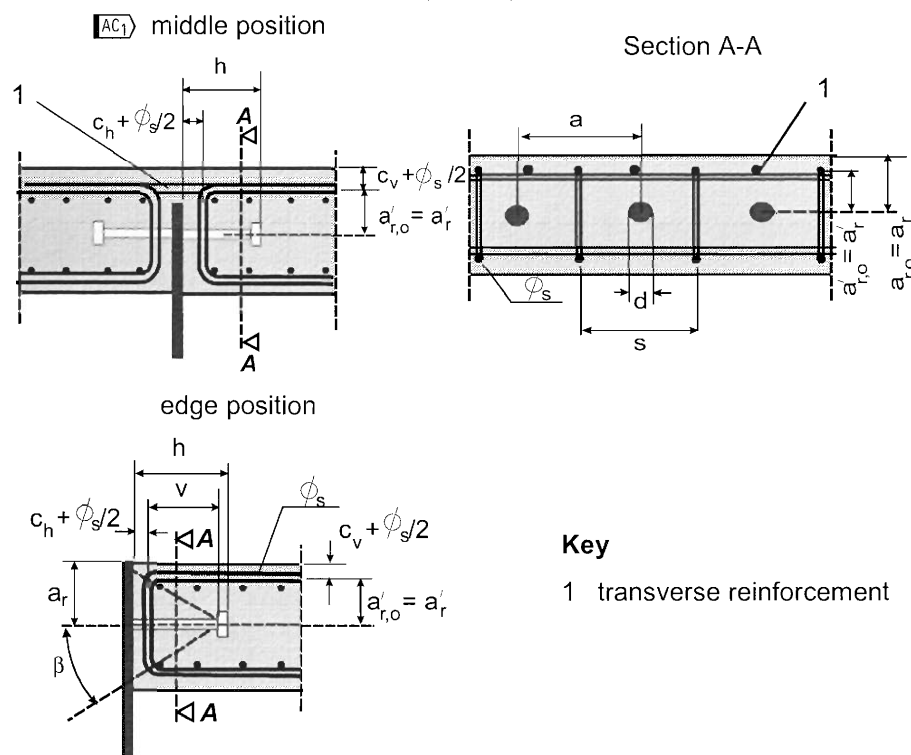

**Figure C.1 - Position and geometrical parameters of shear connections with horizontally arranged studs **AC1****

(2) A failure by pull-out of the stud at the edge of the slab should be prevented by fulfilling the following conditions:

$$\begin{aligned} \text{uncracked concrete:} & \quad \beta \leq 30^\circ \quad \text{or} \quad v \geq \max \{ 110 \text{ mm}; 1.7 a_r'; 1.7 s / 2 \} \\ \text{cracked concrete:} & \quad \beta \leq 23^\circ \quad \text{or} \quad v \geq \max \{ 160 \text{ mm}; 2.4 a_r'; 2.4 s / 2 \} \end{aligned}$$

with  $v$  as shown in Figure C.1.

(3) The splitting force in direction of the slab thickness should be resisted by stirrups, which should be designed for a tensile force according the following equation:

$$T_d = 0.3 P_{Rd,L} \quad (C.2)$$

(4) The influence of vertical shear on the design resistance of a stud connector due to vertical support of the slab should be considered. The interaction may be verified by the following equation:

$$\left( \frac{F_{d,L}}{P_{Rd,L}} \right)^{1,2} + \left( \frac{F_{d,V}}{P_{Rd,V}} \right)^{1,2} \leq 1 \quad (C.3)$$

with

$$P_{Rd,V} = \frac{0.012 (f_{ck} \phi_\ell)^{0,5} (d a/s)^{0,4} (\phi_s)^{0,3} (a'_{r,o})^{0,7} k_v}{\gamma_V} \quad [\text{kN}] \quad (C.4)$$

where  $a_{r,o}'$  is the relevant effective edge distance with  $a_{r,o}' = a_{r,o} - c_v - \phi_s / 2 \geq 50$  mm. Beside the design requirements given in C.1(1) the following conditions should be satisfied:

$$h \geq 100 \text{ mm}; \quad 110 \leq a \leq 250 \text{ mm}; \quad \phi_s \leq 12 \text{ mm}; \quad \phi_\ell \leq 16 \text{ mm}.$$

## C.2 Fatigue strength

(1) The fatigue strength curve of headed studs causing splitting forces in the direction of the slab thickness according to C.1(1) is given for normal-weight concrete by the lower of the values from 6.8.3 and equation (C.5):

$$(\Delta P_R)^m N = (\Delta P_c)^m N_c \quad (C.5)$$

where:

- $\Delta P_R$  is the fatigue strength based on difference of longitudinal shear force per stud;
- $\Delta P_c$  is the reference value of fatigue strength at  $N_c = 2 \times 10^6$  according to Table C.1;
- $m$  is the slope of the fatigue strength curve with  $m = 8$ ;
- $N$  is the number of force range cycles.

In Table C.1  $a_r'$  is the effective edge distance according Figure C.1 and clause C.1(1).

**Table C.1: Fatigue strength  $\Delta P_c$  for horizontally arranged studs**

$a_r'$	[mm]	50	$\geq 100$	<b>NOTE:</b> For $50 < a_r' < 100$ mm $\Delta P_c$ should be determined by linear interpolation.
$\Delta P_c$	[kN]	24.9	35.6	

(2) For the maximum longitudinal shear force per connector 6.8.1(3) applies.



