

The European Union

EDICT OF GOVERNMENT

In order to promote public education and public safety, equal justice for all, a better informed citizenry, the rule of law, world trade and world peace, this legal document is hereby made available on a noncommercial basis, as it is the right of all humans to know and speak the laws that govern them.

EN 1993-5 (2007) (English): Eurocode 3: Design of steel structures - Part 5: Piling [Authority: The European Union Per Regulation 305/2011, Directive 98/34/EC, Directive 2004/18/EC]



BLANK PAGE



English Version

Eurocode 3 - Design of steel structures - Part 5: Piling

Eurocode 3 - Calcul des structures en acier - Partie 5:
Pieux et palplanches

Eurocode 3 - Bemessung und Konstruktion von
Stahlbauten - Teil 5: Pfähle und Spundwände

This European Standard was approved by CEN on 12 June 2006.

CEN members are bound to comply with the CEN/CENELEC Internal Regulations which stipulate the conditions for giving this European Standard the status of a national standard without any alteration. Up-to-date lists and bibliographical references concerning such national standards may be obtained on application to the CEN Management Centre or to any CEN member.

This European Standard exists in three official versions (English, French, German). A version in any other language made by translation under the responsibility of a CEN member into its own language and notified to the CEN Management Centre has the same status as the official versions.

CEN members are the national standards bodies of Austria, Belgium, Bulgaria, Cyprus, Czech Republic, Denmark, Estonia, Finland, France, Germany, Greece, Hungary, Iceland, Ireland, Italy, Latvia, Lithuania, Luxembourg, Malta, Netherlands, Norway, Poland, Portugal, Romania, Slovakia, Slovenia, Spain, Sweden, Switzerland and United Kingdom.



EUROPEAN COMMITTEE FOR STANDARDIZATION
COMITÉ EUROPÉEN DE NORMALISATION
EUROPÄISCHES KOMITEE FÜR NORMUNG

Management Centre: rue de Stassart, 36 B-1050 Brussels

Contents

Page

Foreword	4
1 General	7
1.1 Scope	7
1.2 Normative references.....	8
1.3 Assumptions	8
1.4 Distinction between principles and application rules	9
1.5 Definitions	9
1.6 Symbols	9
1.7 Units	10
1.8 Terminology	11
1.9 Convention for sheet pile axes.....	19
2 Basis of design.....	20
2.1 General	20
2.2 Ultimate limit state criteria.....	20
2.3 Serviceability limit state criteria.....	21
2.4 Site investigation and soil parameters	21
2.5 Analysis	22
2.6 Design assisted by testing.....	23
2.7 Driveability.....	24
3 Material properties.....	25
3.1 General	25
3.2 Bearing piles	25
3.3 Hot rolled steel sheet piles.....	25
3.4 Cold formed steel sheet piles.....	25
3.5 Sections used for waling and bracing	26
3.6 Connecting devices.....	26
3.7 Steel members used for anchors	26
3.8 Steel members used for combined walls	26
3.9 Fracture toughness.....	27
4 Durability	28
4.1 General	28
4.2 Durability requirements for bearing piles.....	29
4.3 Durability requirements for sheet piling.....	30
4.4 Corrosion rates for design.....	30
5 Ultimate limit states.....	32
5.1 Basis	32
5.2 Sheet piling.....	32
5.3 Bearing piles.....	46
5.4 High modulus walls.....	48
5.5 Combined walls	49
6 Serviceability limit states	52
6.1 Basis	52
6.2 Displacements of retaining walls.....	52
6.3 Displacements of bearing piles.....	52
6.4 Structural aspects of steel sheet piling.....	52
7 Anchors, walings, bracing and connections	54
7.1 General	54

7.2	Anchorage	54
7.3	Walings and bracing	56
7.4	Connections	56
8	Execution	64
8.1	General	64
8.2	Steel sheet piling	64
8.3	Bearing piles	64
8.4	Anchorage	64
8.5	Walings, bracings and connections	64
A	[normative] - Thin walled steel sheet piling	65
A.1	General	65
A.2	Basis of design	66
A.3	Properties of materials and cross-sections	66
A.4	Local buckling	70
A.5	Resistance of cross-sections	72
A.6	Design by calculation	76
A.7	Design assisted by testing	77
B	[informative] - Testing of thin walled steel sheet piles	79
B.1	General	79
B.2	Single span beam test	79
B.3	Intermediate support test	80
B.4	Double span beam test	81
B.5	Evaluation of test results	82
C	[informative] - Guidance for the design of steel sheet piling	84
C.1	Design of sheet pile cross section at ultimate limit state	84
C.2	Serviceability limit state	87
D	[informative] - Primary elements of combined walls	89
D.1	I-sections used as primary elements	89
D.2	Tubular piles used as primary elements	91

Foreword

This European Standard EN 1993-5, “Eurocode 3: Design of steel structures: Part 5 Piling”, has been prepared by Technical Committee CEN/TC250 « Structural Eurocodes », the Secretariat of which is held by BSI. CEN/TC250 is responsible for all Structural Eurocodes.

This European Standard shall be given the status of a National Standard, either by publication of an identical text or by endorsement, at the latest by August 2007, and conflicting National Standards shall be withdrawn at latest by March 2010.

This Eurocode supersedes ENV 1993-5:1998.

According to the CEN-CENELEC Internal Regulations, the National Standard Organizations of the following countries are bound to implement this European Standard: Austria, Belgium, Bulgaria, Cyprus, Czech Republic, Denmark, Estonia, Finland, France, Germany, Greece, Hungary, Iceland, Ireland, Italy, Latvia, Lithuania, Luxembourg, Malta, Netherlands, Norway, Poland, Portugal, Romania, Slovakia, Slovenia, Spain, Sweden, Switzerland and United Kingdom..

Background to the Eurocode programme

In 1975, the Commission of the European Community decided on an action programme in the field of construction, based on article 95 of the Treaty. The objective of the programme was the elimination of technical obstacles to trade and the harmonisation of technical specifications.

Within this action programme, the Commission took the initiative to establish a set of harmonised technical rules for the design of construction works which, in a first stage, would serve as an alternative to the national rules in force in the Member States and, ultimately, would replace them.

For fifteen years, the Commission, with the help of a Steering Committee with Representatives of Member States, conducted the development of the Eurocodes programme, which led to the first generation of European codes in the 1980's.

In 1989, the Commission and the Member States of the EU and EFTA decided, on the basis of an agreement¹ between the Commission and CEN, to transfer the preparation and the publication of the Eurocodes to the CEN through a series of Mandates, in order to provide them with a future status of European Standard (EN). This links de facto the Eurocodes with the provisions of all the Council's Directives and/or Commission's Decisions dealing with European standards (e.g. the Council Directive 89/106/EEC on construction products - CPD - and Council Directives 93/37/EEC, 92/50/EEC and 89/440/EEC on public works and services and equivalent EFTA Directives initiated in pursuit of setting up the internal market).

The Structural Eurocode programme comprises the following standards generally consisting of a number of Parts:

EN 1990	Eurocode: Basis of structural design
EN 1991	Eurocode 1: Actions on structures
EN 1992	Eurocode 2: Design of concrete structures
EN 1993	Eurocode 3: Design of steel structures
EN 1994	Eurocode 4: Design of composite steel and concrete structures
EN 1995	Eurocode 5: Design of timber structures
EN 1996	Eurocode 6: Design of masonry structures
EN 1997	Eurocode 7: Geotechnical design
EN 1998	Eurocode 8: Design of structures for earthquake resistance
EN 1999	Eurocode 9: Design of aluminium structures

¹ Agreement between the Commission of the European Communities and the European Committee for Standardisation (CEN) concerning the work on EUROCODES for the design of building and civil engineering works (BC/CEN/03/89).

Eurocode standards recognise the responsibility of regulatory authorities in each Member State and have safeguarded their right to determine values related to regulatory safety matters at national level where these continue to vary from State to State.

Status and field of application of Eurocodes

The Member States of the EU and EFTA recognise that Eurocodes serve as reference documents for the following purposes:

- as a means to prove compliance of building and civil engineering works with the essential requirements of Council Directive 89/106/EEC, particularly Essential Requirement N°1 – Mechanical resistance and stability - and Essential Requirement N°2 - Safety in case of fire;
- as a basis for specifying contracts for construction works and related engineering services;
- as a framework for drawing up harmonised technical specifications for construction products (ENs and ETAs)

The Eurocodes, as far as they concern the construction works themselves, have a direct relationship with the Interpretative Documents² referred to in Article 12 of the CPD, although they are of a different nature from harmonised product standard³. Therefore, technical aspects arising from the Eurocodes work need to be adequately considered by CEN Technical Committees and/or EOTA Working Groups working on product standards with a view to achieving a full compatibility of these technical specifications with the Eurocodes. The Eurocode standards provide common structural design rules for everyday use for the design of whole structures and component products of both a traditional and an innovative nature. Unusual forms of construction or design conditions are not specifically covered and additional expert consideration will be required by the designer in such cases.

National Standards implementing Eurocodes

The National Standards implementing Eurocodes will comprise the full text of the Eurocode (including any annexes), as published by CEN, which may be preceded by a National title page and National foreword, and may be followed by a National Annex (informative).

The National Annex (informative) may only contain information on those parameters which are left open in the Eurocode for national choice, known as Nationally Determined Parameters, to be used for the design of buildings and civil engineering works to be constructed in the country concerned, i.e.:

- values for partial factors and/or classes where alternatives are given in the Eurocode,
- values to be used where a symbol only is given in the Eurocode,
- geographical and climatic data specific to the Member State, e.g. snow map,
- the procedure to be used where alternative procedures are given in the Eurocode,
- references to non-contradictory complementary information to assist the user to apply the Eurocode.

2 According to Art. 3.3 of the CPD, the essential requirements (ERs) shall be given concrete form in interpretative documents for the creation of the necessary links between the essential requirements and the mandates for hENs and ETAGs/ETAs.

3 According to Art. 12 of the CPD the interpretative documents shall:

- (a) give concrete form to the essential requirements by harmonising the terminology and the technical bases and indicating classes or levels for each requirement where necessary;
- (b) indicate methods of correlating these classes or levels of requirement with the technical specifications, e.g. methods of calculation and of proof, technical rules for project design, etc.;
- (c) serve as a reference for the establishment of harmonised standards and guidelines for European technical approvals.

The Eurocodes, de facto, play a similar role in the field of the ER 1 and a part of ER 2.

Links between Eurocodes and product harmonised technical specifications (ENs and ETAs)

There is a need for consistency between the harmonised technical specifications for construction products and the technical rules for works⁴. Furthermore, all the information accompanying the CE Marking of the construction products which refer to Eurocodes should clearly mention which Nationally Determined Parameters have been taken into account.

Additional information specific to EN 1993-5

EN 1993-5 gives design rules for steel sheet piling and bearing piles to supplement the generic rules in EN 1993-1.

EN 1993-5 is intended to be used with Eurocodes EN 1990 - Basis of design, EN 1991 - Actions on structures and Part 1 of EN 1997 Geotechnical Design.

Matters that are already covered in those documents are not repeated.

EN 1993-5 is intended for use by

- committees drafting design related product, testing and execution standards,
- clients (e.g. for the formulation of their specific requirements)
- designers and constructors
- relevant authorities.

Numerical values for partial factors and other parameters are recommended as basic values that provide an acceptable level of safety. They have been selected assuming that an appropriate level of workmanship and quality management applies.

Annex A and Annex B have been prepared to complement the provisions of EN 1993-1-3 for class 4 steel sheet piles.

Annex C gives guidance on the plastic design of steel sheet pile retaining structures.

Annex D gives one possible set of design rules for primary elements of combined walls.

Reference should be made to EN 1997 for geotechnical design which is not covered in this document.

National Annex for EN 1993-5

This standard gives alternative procedures, values and recommendations for classes with notes indicating where national choices may have to be made. Therefore the National Standard implementing EN 1993-5 should have a National Annex containing all Nationally Determined Parameters to be used for the design of buildings and civil engineering works to be constructed in the relevant country.

National choice is allowed in EN 1993-5 through clauses:

3.7 (1)	5.2.2 (13)	7.2.3 (2)
3.9 (1)P	5.2.5 (7)	7.4.2 (4)
4.4 (1)	5.5.4 (2)	A.3.1 (3)
5.1.1 (4)	6.4 (3)	B.5.4 (1)
5.2.2 (2)	7.1 (4)	D.2.2 (5)

4 See Art. 3.3 and Art. 12 of the CPD, as well as clauses 4.2, 4.3.1, 4.3.2 and 5.2 of ID 1.

1 General

1.1 Scope

- (1) Part 5 of EN 1993 provides principles and application rules for the structural design of bearing piles and sheet piles made of steel.
- (2) It also provides examples of detailing for foundation and retaining wall structures.
- (3) The field of application includes:
 - steel piled foundations for civil engineering works on land and over water;
 - temporary or permanent structures needed to carry out steel piling work;
 - temporary or permanent retaining structures composed of steel sheet piles, including all kinds of combined walls.
- (4) The field of application excludes:
 - offshore platforms;
 - dolphins.
- (5) Part 5 of EN 1993 also includes application rules for steel piles filled with concrete.
- (6) Special requirements for seismic design are not covered. Where the effects of ground movements caused by earthquakes are relevant see EN 1998.
- (7) Design provisions are also given for walings, bracing and anchorages, see section 7.
- (8) The design of steel sheet piling using class 1, 2 and 3 cross-sections is covered in sections 5 and 6, whereas the design of class 4 cross-sections is covered in annex A.

NOTE: The testing of class 4 sheet piles is covered in annex B.

- (9) The design procedures for crimped U-piles and straight web steel sheet piles utilise design resistances obtained by testing. Reference should be made to EN 10248 for testing procedures.
- (10) Geotechnical aspects are not covered in this document. Reference is made to EN 1997.
- (11) Provisions for taking into account the effects of corrosion in the design of piling are given in section 4.
- (12) Allowance for plastic global analysis in accordance with 5.4.3 of EN 1993-1-1 is given in 5.2.

NOTE: Guidance for the design of steel sheet pile walls allowing for plastic global analysis is given in Annex C.

- (13) The design of combined walls at ultimate limit states is covered in section 5 including general provisions for the design of primary elements.

NOTE: Guidance for the design of both tubular piles and I-sections used as primary elements is given in Annex D.

1.2 Normative references

This European Standard incorporates by dated or undated reference, provisions from other publications. These normative references are cited at the appropriate places in the text and the publications are listed hereafter. For dated references, subsequent amendments to, or revisions of, any of these publications apply to this European Standard only when incorporated in it by amendment or revision. For undated references the latest edition of the publication referred to applies.

EN 1990	Eurocode:	Basis of structural design
EN 1991	Eurocode 1:	Actions on structures
EN 1992	Eurocode 2:	Design of concrete structures
EN 1993	Eurocode 3:	Design of steel structures
	Part 1.1:	General rules: General rules and rules for buildings;
	Part 1.2:	General rules: Structural fire design;
	Part 1.3:	General rules: Supplementary rules for cold formed thin gauge members and sheeting;
	Part 1.5:	General rules: Plated structural elements;
	Part 1.6:	General rules: Strength and stability of shell structures
	Part 1.8:	General rules: Design of joints
	Part 1.9:	General rules: Fatigue
	Part 1.10:	General rules: Material toughness and through-thickness properties
	Part 1.11:	General rules: Design of structures with tension components made of steel
EN 1994	Eurocode 4:	Design of composite steel and concrete structures
EN 1997	Eurocode 7:	Geotechnical design
EN 1998	Eurocode 8:	Earthquake resistant design of structures;
EN 10002		Metallic materials; tensile testing;
EN 10027		Designation systems for steel;
EN 10210		Hot finished structural hollow sections of non-alloy fine grain structural steels;
EN 10219		Cold formed structural hollow sections of non-alloy fine grain structural steels;
EN 10248		Hot rolled sheet piling of non alloy steels;
EN 10249		Cold formed sheet piling of non alloy steels;
EN 1536		Execution of special geotechnical work - Bored piles;
EN 1537		Execution of special geotechnical work - Ground anchors;
EN 12063		Execution of special geotechnical work - Sheet-pile walls;
EN 12699		Execution of special geotechnical work - Displacement piles;
EN 14199		Execution of special geotechnical work - Micro piles;
EN 10045		Metallic materials; Charpy impact test;
EN 1090-2		Execution of steel structures and aluminium structures, Part 2: Technical requirements for steel structures.

1.3 Assumptions

(1) In addition to the general assumptions in EN 1990 the following assumptions apply:

Installation and fabrication of steel piles and steel sheet piles are in accordance with EN 12699, EN 14199 and EN 12063.

1.4 Distinction between principles and application rules

(1)P Reference shall be made to 1.4 of EN 1990.

1.5 Definitions

For the purpose of this standard, the following definitions apply:

1.5.1 foundation: Part of a construction work including piles and possibly their pile cap.

1.5.2 retaining structure: A construction element including walls retaining soil, similar material and/or water, and, where relevant, their support systems (e.g. anchorages).

1.5.3 soil-structure interaction: The mutual influence of deformations on soil and a foundation or a retaining structure.

1.6 Symbols

(1) In addition to those given in EN 1993-1-1, the following main symbols are used:

c Slant height of the web of steel sheet piles, see Figure 5-1;

α Inclination of the web, see Figure 5-1.

(2) In addition to those given in EN 1993-1-1, the following subscripts are used:

red Reduced.

(3) In addition to those given in EN 1993-1-1, the following major symbols are used:

A_v Projected shear area, see Figure 5-1;

F_{Ed} Design value of the anchor force;

$F_{Q,Ed}$ Additional horizontal force resulting from global buckling to be resisted by the toe of a sheet pile to allow for the assumption of a non-sway buckling mode, see Figure 5-4;

$F_{t,Rd}$ Design tension resistance of an anchor;

$F_{t,Ed}$ Design value of the circumferential tensile force in a cellular cofferdam;

$F_{t,ser}$ Axial force in an anchor under characteristic loading;

$F_{ta,Ed}$ Design tensile force in the arc cell of a cellular cofferdam;

$F_{tc,Ed}$ Design tensile force in the common wall of a cellular cofferdam;

$F_{tg,Rd}$ Design tensile resistance of shafts of anchors;

$F_{tm,Ed}$ Design tensile force in the main cell of a cellular cofferdam;

- $F_{ts,Rd}$ Design tensile resistance of simple straight web steel sheet piles;
- $F_{tt,Rd}$ Design tensile resistance of threads of anchors;
- $R_{c,Rd}$ Design resistance of a sheet pile to a local transverse force;
- $R_{tw,Rd}$ Design tensile resistance of the webs of a sheet pile to the introduction of a local transverse force;
- $R_{Vf,Rd}$ Design shear resistance of the flange of a sheet pile to the introduction of a local transverse force;
- $p_{m,Ed}$ Design value of the internal pressure acting in the main cell of a cellular cofferdam;
- r_a Initial radius of the arc cell in a cellular cofferdam;
- r_m Initial radius of the main cell in a cellular cofferdam;
- t_f Nominal flange thickness of a steel sheet pile;
- t_w Nominal web thickness of steel sheet piles;
- β_B Factor accounting for the possible reduction of the section modulus of U-piles due to insufficient shear force transmission in the interlocks;
- β_D Factor accounting for the possible reduction of the bending stiffness of U-piles due to insufficient shear force transmission in the interlocks;
- β_R Factor accounting for the interlock resistance of straight web steel sheet piles;
- β_T Factor accounting for the behaviour of a welded junction pile at ultimate limit states;
- $\beta_{o,l}$ Factor accounting for the reduction of the second moment of area about the wall axis due to the ovalisation of the tube;
- ρ_p Factor accounting for the effects of differential water pressure on transverse local plate bending.

(4) Further symbols are defined where they first occur.

1.7 Units

(1) S.I. units should be used in accordance with ISO 1000.

(2) The following units are recommended for use in calculations:

- forces and loads: kN, kN/m, kN/m²;
- unit mass: kg/m³;
- unit weight: kN/m³;
- stresses and strengths: N/mm² (MN/m² or MPa);
- bending moments: kNm;
- torsional moments: kNm.

1.8 Terminology

For the purposes of this Standard, the following terminology is used:

NOTE: Figure 1-1 to Figure 1-10 are only examples and are provided in order to enhance the understanding of the wording of the terminology used. The examples are by no means exhaustive and they do not represent any preferred detailing.

1.8.1 Anchorage

The general expression used to describe the anchoring system at the back of a retaining wall, such as dead-man anchors, anchor plates or anchor screens, screw anchors, ground anchors, anchor piles and expanded bodies. Examples of connections between anchors and a sheet pile wall are shown in Figure 1-1.

1.8.2 Anchored wall

A wall whose stability depends upon penetration of the sheet piling into the ground and also upon one or more anchor levels.

1.8.3 Bearing piles

Structural elements (hollow type, H-type, cruciform or X-type cross-sections) incorporated into the foundations of building or civil engineering works and used for resisting axial compressive or tensile forces, moments and transverse (shear) forces (see Table 1-1). The bearing resistance is achieved by base resistance or shaft friction or a combination of both.

1.8.4 Bracing

Struts perpendicular or at an angle to the front face of a retaining wall, supporting the wall and usually connected to the walings (see Figure 1-2).

1.8.5 Cantilever wall

Wall whose stability depends solely upon the penetration of the sheet piling into the ground.

1.8.6 Cellular cofferdams

Cofferdams constructed of straight web profiles with interlock tensile strength sufficient to resist the circumferential tension developed in the cellular walls due to the radial pressure of the contained fill (see Figure 1-3). The stability of these cells is obtained by the self-weight of the fill. Two basic types of cellular cofferdams are:

- Cellular cofferdams involving circular cells: This type of cofferdam consists of individual cells of large diameter connected together by arcs of smaller diameter (see Figure 1-4a);
- Cellular cofferdams involving diaphragm cells: This type of cofferdam consists of two rows of circular arcs connected together by diaphragms perpendicular to the axis of the cofferdam (see Figure 1-4b).

1.8.7 Combined walls

Retaining walls composed of primary and secondary elements. The primary elements are normally steel tubular piles, I-sections or built up box types, spaced uniformly along the length of the wall. The secondary elements are generally steel sheet piles of various types installed in the spaces between the primary elements and connected to them by interlocks (see Figure 1-5).

1.8.8 Double U-pile

Two threaded single U sheet piles with a crimped or welded common interlock allowing for shear force transmission.

1.8.9 Driveability

The ability of a sheet pile or bearing pile to be driven through the ground strata to the required penetration depth without detrimental effects.

1.8.10 Driving

Any method for installing a pile into the ground to the required depth, such as impact driving, vibrating, pressing or screwing or by a combination of these or other methods.

1.8.11 High modulus wall

A high strength retaining wall formed by interlocking steel elements that have the same geometry. The elements may consist of fabricated profiles, see Figure 1-6, to obtain a high section modulus.

1.8.12 Interlock

The portion of a steel sheet pile or other sheeting that connects adjacent elements by means of a thumb and finger or similar configuration to make a continuous wall. Interlocks may be described as

- Free: Threaded interlocks that are neither crimped nor welded;
- Crimped: Interlocks of threaded single piles that have been mechanically connected by crimped points;
- Welded: Interlocks of threaded single piles that have been mechanically connected by continuous or intermittent welding.

1.8.13 Jagged wall

Special sheet pile wall configuration in which the single piles are arranged either to enhance the moment of inertia of the wall (see example in Figure 1-7) or to suit special applications (see example in Figure 1-8).

1.8.14 Pile coupler

A mechanical friction sleeve used to lengthen a steel tubular or X shaped pile.

1.8.15 Propped wall

A retaining wall whose stability depends upon penetration of the sheet piling into the ground and also upon one or more levels of bracing.

1.8.16 Soldier or king pile wall

Soldier or king pile walls consist of vertical piles (king, master or soldier piles) driven at intervals, supporting intermediate horizontal elements (boarding, planks or lagging), see Figure 1-9. The king or master piles may be rolled or welded I-sections, tubular or box sections.

1.8.17 Steel box piles

Piles with a non-circular hollow shape formed from two or more hot-rolled sections continuously or intermittently welded together in longitudinal direction (see Table 1-1).

1.8.18 Steel tubular piles

Piles of circular cross-section formed by the seamless, longitudinal or helical welding processes (see Table 1-1).

1.8.19 Steel sheet pile

The individual steel elements of which a sheet pile wall is composed. The types of steel sheet piles covered in this Part 5 are given in Table 1-2: Z-shaped, U-shaped and straight web profiles, and in Table A-1 of

Annex A for cold formed sheet piling. The interlocks of the Z-piles are located on the extreme fibres of the wall, whereas the interlocks of U-shaped and straight web profiles are located on the axis of the retaining wall.

1.8.20 Steel sheet pile wall

The screen of sheet piles that forms a continuous wall by threading of the interlocks.

1.8.21 T-connection

Special element, see Figure 1-10, to connect two cellular cofferdams by arcs of smaller diameter, see Figure 1-3.

1.8.22 Triple U-pile

A sheet pile consisting of three threaded single U sheet piles with two crimped or welded common interlocks allowing for shear force transmission.

1.8.23 Waling

Horizontal beam, usually of steel or reinforced concrete, fixed to the retaining wall and used to transmit the design support force for the wall into the tie rods or struts.

Table 1-1: Examples of cross-sections of steel bearing piles







Type of cross-section	Representation
Hollow type (examples), <i>see Note</i>	
H type	
X type	
<p>Note: Reference should be made to EN 12699 and EN 14199 for execution details.</p>	

Table 1-2: Steel sheet piles

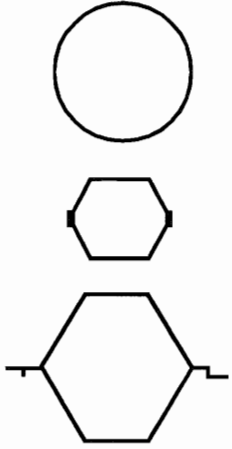
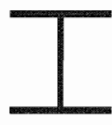
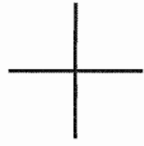
Type of cross-section	Single pile	Double pile
Z - profiles		
U - profiles		
Straight web profiles		

Note: Reference should be made to EN 10248 for details of the interlocks.

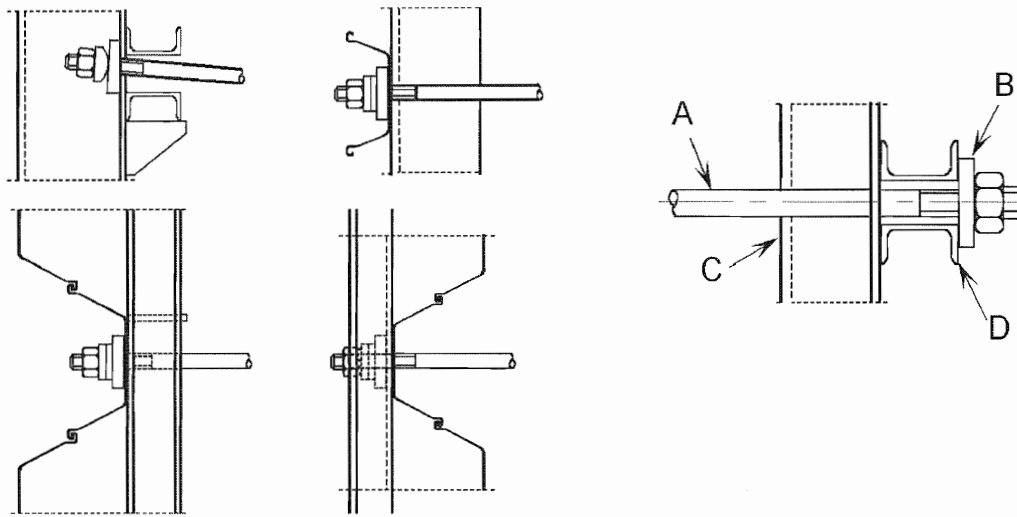

A Tie rod; B Washer plate;
C Sheet pile; D Waling

Figure 1-1: Examples of connections between anchors and sheet pile walls

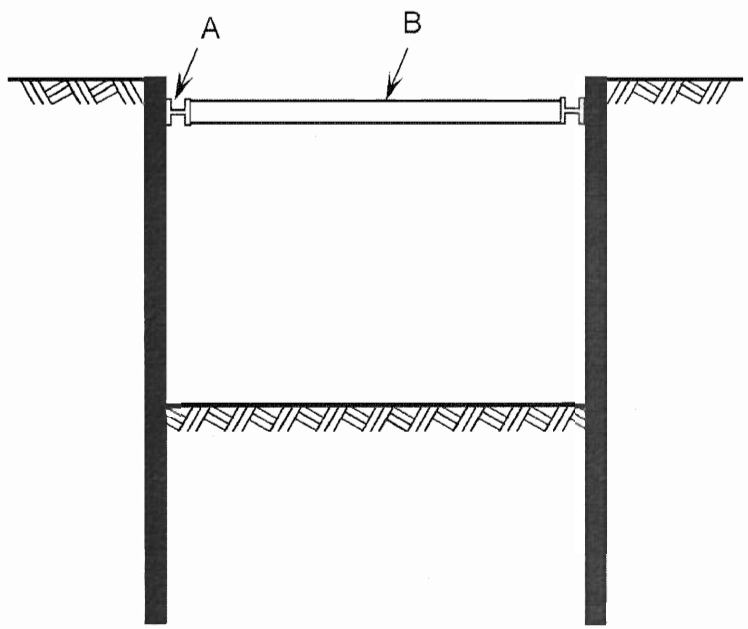

A Waling; B Strut

Figure 1-2: Example of bracing

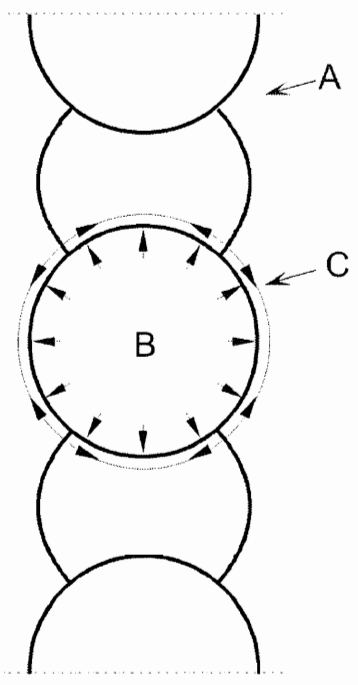

A T-junction; B Internal pressure;
C Circumferential tensile force

Figure 1-3: Cellular cofferdams

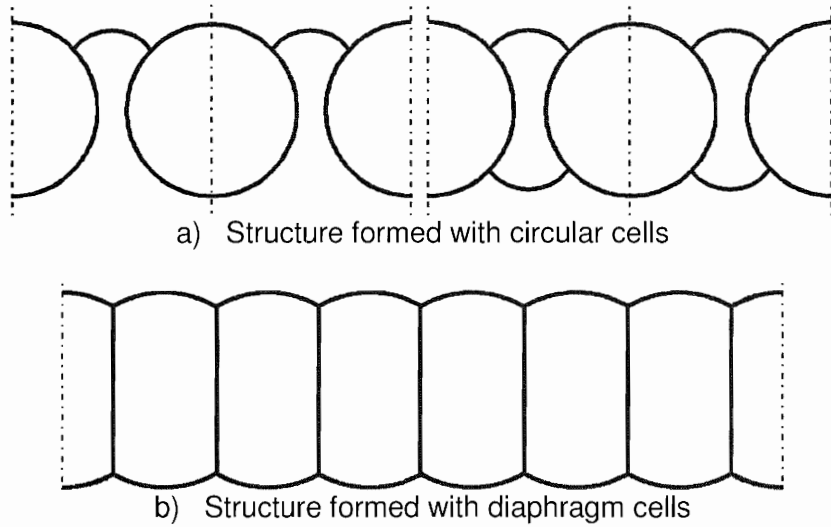
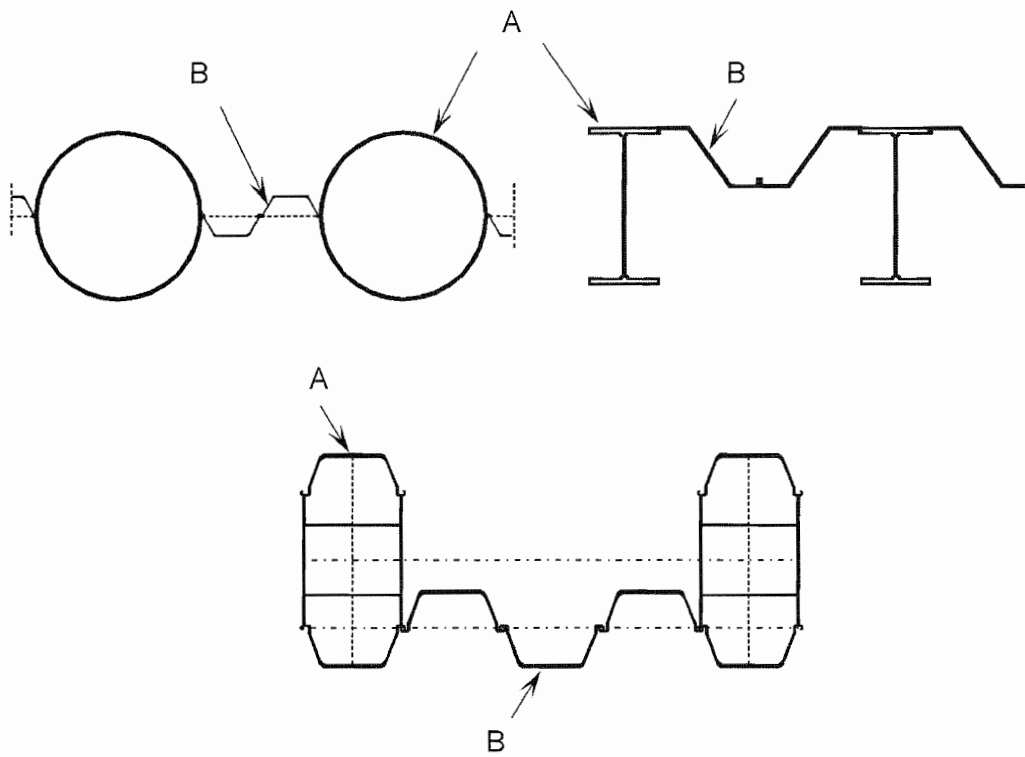
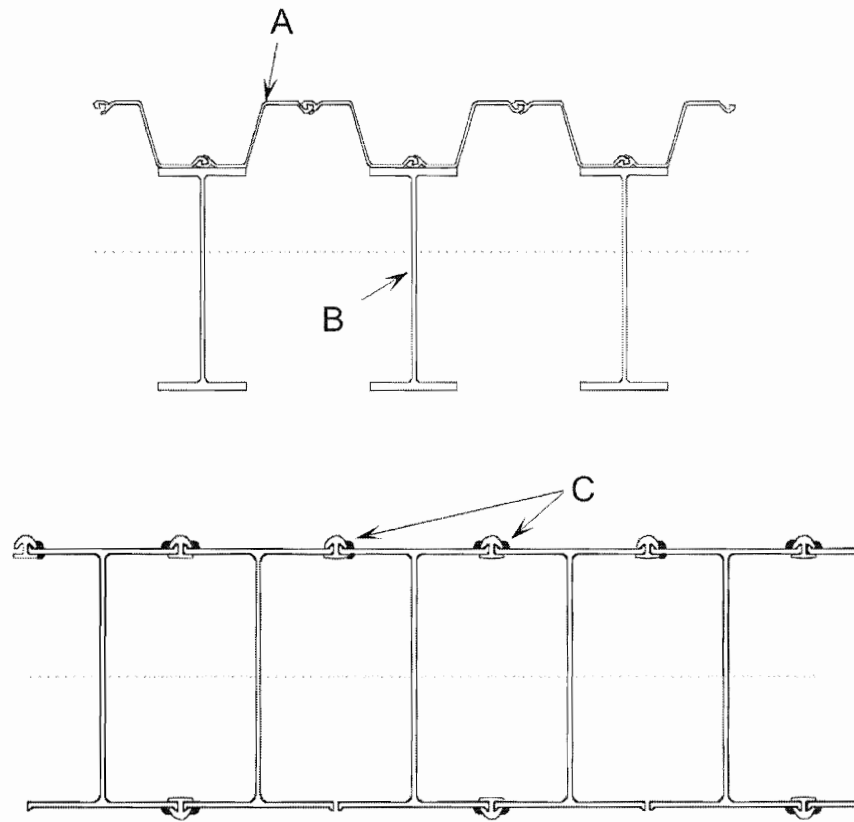

Figure 1-4: Examples of cellular structures



A Primary Elements; B Secondary Elements

Figure 1-5: Examples of combined walls



A Sheet pile welded to I-Section;
B I-section;
C Connector welded to I-Section

Figure 1-6: Examples of high modulus walls

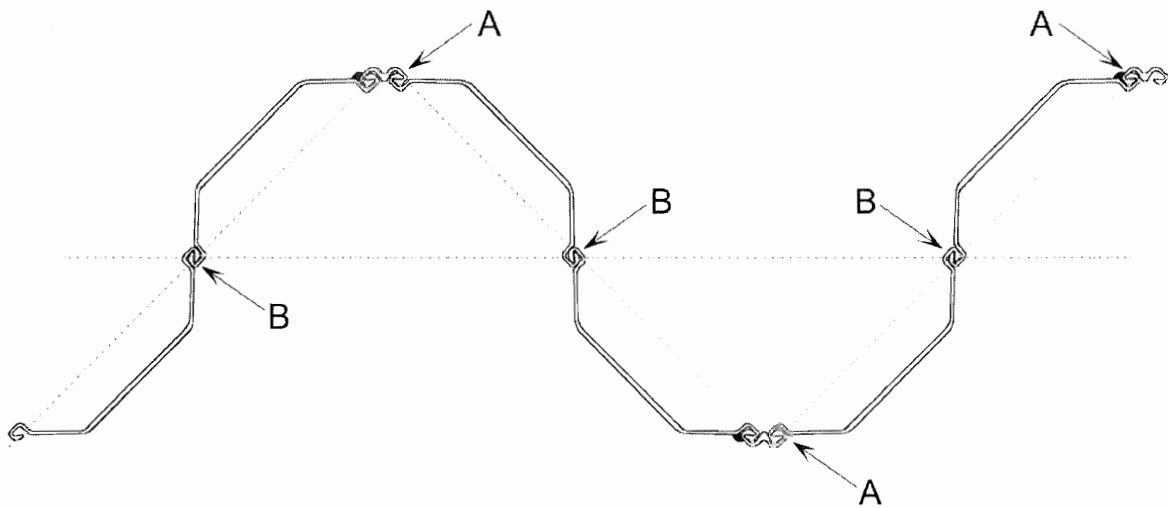

A Connector welded to one double pile; B Crimped Interlock

Figure 1-7: Example of a jagged wall formed from U-profiles



Figure 1-8: Example of a jagged wall formed from Z-profiles

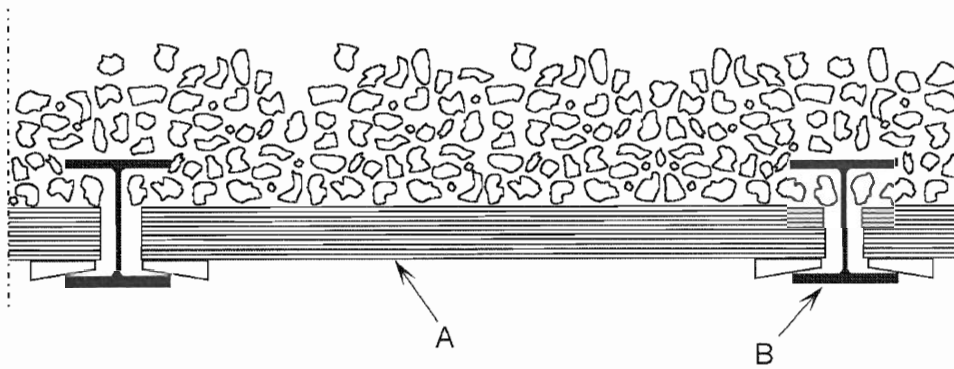

A Lagging, boarding, planks;

B Soldier, king or master pile

Figure 1-9: Example of a soldier pile wall

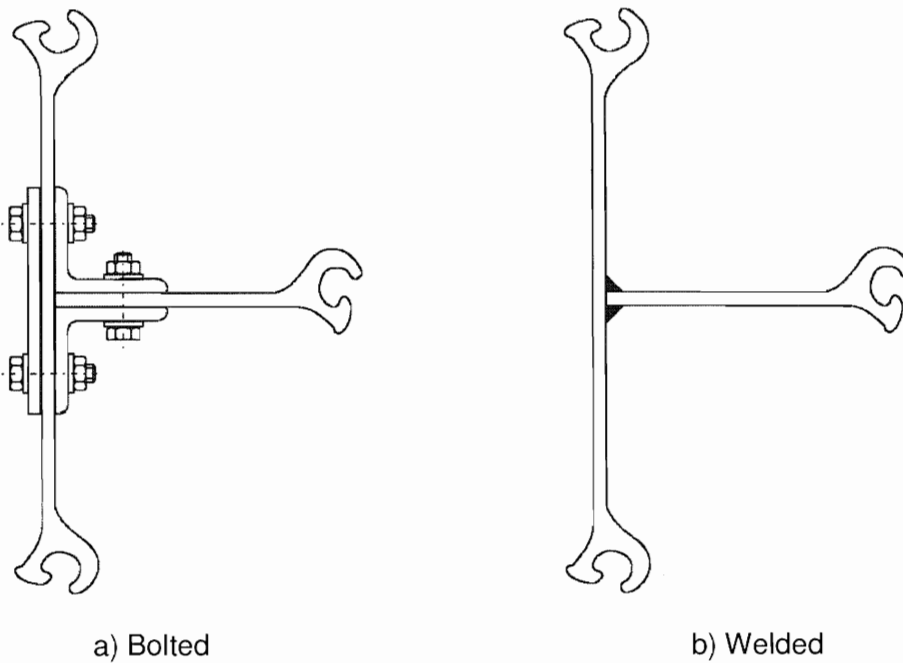

a) Bolted

b) Welded

Figure 1-10: Examples of T-connections

1.9 Convention for sheet pile axes

(1) For sheet piling the following axis convention is used:

- generally
 - $x - x$ is the longitudinal axis of a pile;
 - $y - y$ is the cross-sectional axis parallel to the retaining wall;
 - $z - z$ is the other cross-sectional axis;
- where necessary
 - $u - u$ is the principal axis nearest to the plane of the retaining wall if this does not coincide with the $y - y$ axis;
 - $v - v$ is the other principal axis if this does not coincide with $z - z$.

NOTE: This differs from the axis convention used in EN 1993-1-1. Care therefore needs to be taken when cross-reference is made to Part 1.1.

2 Basis of design

2.1 General

- (1)P For the design of bearing piles and sheet piling, including the design of walings, bracing and anchorages, the provisions of EN 1990 apply, except where different provisions are given in this document.
- (2) In the following, specific provisions are given for the design of bearing piles and sheet piling to fulfil the safety and durability requirements for both serviceability and ultimate limit states.
- (3) The bearing resistance of the ground should be determined according to EN 1997-1.
- (4)P All design situations, including each stage of execution and use, shall be taken into account, see EN 1990.
- (5) The driveability of bearing piles and sheet piles should be taken into account in the design of the structure, see 2.7.
- (6) The provisions given in this document apply equally to temporary and permanent structures, unless otherwise stated, see EN 1990.
- (7) In the following distinction is made between bearing piles and retaining walls where relevant.
- (8) For provisions regarding walings, bracing, connections and anchors, reference should be made to section 7.

2.2 Ultimate limit state criteria

- (1)P The following ultimate limit state criteria shall be taken into account:

- a) failure of the construction by failure in the soil (the soil resistance is exceeded);
- b) structural failure;
- c) combination of failure in the soil and structural failure.

NOTE: Failure of adjacent structures may be caused by deformations resulting from excavation. If adjacent structures are sensitive to such deformations, recommendations for dealing with the situation can be given for the project.

- (2) Verifications related to ultimate limit state criteria should be carried out in accordance with EN 1997-1.
- (3) Depending on the design situation the resistance to one or more of the following modes of structural failure should be verified:
- for bearing piles:
 - failure due to bending and/or axial force;
 - failure due to overall flexural buckling, taking account of the restraint provided by the ground and by the supported structure at the connections to it;
 - local failure at points of load application;

- fatigue.
- for retaining walls:
 - failure due to bending and/or axial force;
 - failure due to overall flexural buckling, taking account of the restraint provided by the soil;
 - local buckling due to overall bending;
 - local failure at points of load application (e.g. web crippling);
 - fatigue.

2.3 Serviceability limit state criteria

(1) Unless otherwise specified, the following serviceability limit state criteria should be taken into account:

- for bearing piles:
 - limits to vertical settlements or horizontal displacements necessary to suit the supported structure;
 - vibration limits necessary to suit structures directly connected to, or adjacent to, the bearing piles.
- for retaining walls:
 - deformation limits necessary to suit the serviceability of the retaining wall itself;
 - limits to horizontal displacements, vertical settlements or vibrations, necessary to suit structures directly connected to, or adjacent to, the retaining wall itself.

(2) Values for the limits given in (1), in relation to the combination of actions to be taken into account according to EN 1990, should be defined for each project.

(3) Where relevant, values for limits imposed by adjacent structures should be defined for the project. Guidance for determining such limits is given in EN 1997-1.

NOTE: Serviceability criteria may be the governing criteria for the design.

2.4 Site investigation and soil parameters

(1)P Parameters for soil and/or backfill shall be determined from geotechnical investigation in accordance with EN 1997.

2.5 Analysis

2.5.1 General

- (1) Global analysis should be carried out to determine the effects of actions (internal forces and moments, stresses, strains and displacements) over the whole or part of the structure. Additional local analyses of the structure should be carried out where necessary, e.g. load application points, connections etc.
- (2) Analyses may be carried out using idealisations of the geometry, behaviour of the structure and behaviour of the soil. The idealisations should be selected with regard to the design situation.
- (3) Except where the design is sensitive to the effects of variations, assessment of the effects of actions in piled foundations and in sheet pile walls may be carried out on the basis of nominal values of geometrical data.
- (4) Structural fire design should be taken into account through the provisions of EN 1993-1-2 and EN 1991-1-2.

2.5.2 Assessment of actions

- (1) Where relevant, actions should be taken from EN 1991, otherwise they should be defined for the project and agreed with the client.
- (2) In the case of piled foundations, actions due to vertical or transverse ground movements (e.g. down-drag, etc.) should be assessed in accordance with EN 1997-1.
- (3) The actions transmitted to the structure through the soil should be assessed by using models selected in accordance with EN 1997-1, or defined for the project and agreed with the client.
- (4) Where necessary, the effects of actions resulting from variations in temperature with time, or from special loads not specified in EN 1991, should be taken into account.

NOTE 1: It may be necessary to take into account temperature effects, for example on struts, if there are likely to be large variations in temperature. The design may prescribe measures to reduce the influence of temperature variations.

NOTE 2: Examples of special loads are:

- loads due to falling objects or swinging buckets;
- loads from excavators and cranes;
- imposed loads such as pumps, access ways, intermediate struts, staging for materials or stacking of bundles of steel reinforcement.

(5) Unless otherwise specified, for retaining walls subject to loads from a road or a railway track, simplified models for such loads (for example uniformly distributed loads) derived from those defined for bridges may be used, see EN 1991-2.

2.5.3 Structural analysis

2.5.3.1 General

- (1) The analysis of the structure should be carried out using a suitable soil-structure model in accordance with EN 1997-1.
- (2) Depending on the design situation, anchors may be modelled either as simple supports or as springs.
- (3) If connections have a major influence on the distribution of internal forces and moments, they should be taken into account in the structural analysis.

2.5.3.2 Ultimate limit states

- (1) The structural analysis of piled foundations for ultimate limit states may be based on the same type of model as used for serviceability limit states.
- (2) Where accidental situations need to be taken into account, the assessment of effects of actions in the piles in a foundation may be carried out on the basis of a plastic model, both for the whole structure and for the soil-structure interaction.

NOTE: An example of an accidental situation is a ship collision against a bridge pier.

- (3) Assessment of the effects of actions in sheet pile retaining walls should be carried out on the basis of the relevant failure mode for ultimate limit state verifications, using a soil structure interaction model as defined in 2.5.3.1 (1).

2.5.3.3 Serviceability limit states

- (1) For sheet pile retaining walls, and also for piled foundations, the global analysis should be based on a linear elastic model of the structure, and a soil-structure model as defined in 2.5.3.1(1).
- (2) It should be shown that no plastic deformations occur in the structure as a result of serviceability loading.

2.6 Design assisted by testing

2.6.1 General

- (1) The general provisions for design assisted by testing given in EN 1990, EN 1993-1-1 and EN 1997-1 should be satisfied.

NOTE: Guidance on the determination of design resistance from tests is given in Annex D of EN 1990.

2.6.2 Bearing piles

(1) For guidance on the testing of bearing piles, reference should be made to EN 1997-1, EN 12699 and EN 14199.

2.6.3 Steel sheet piling

(1) The assumptions made in the design of sheet piling may be verified in stages by on-site testing during execution of the work (for instance in the case of an excavation procedure).

(2) Reference should be made to EN 1997-1 for calibration of a calculation model and modification of the design during execution.

2.6.4 Anchorages

(1) The general provisions for design assisted by testing given in EN 1997-1, EN 1537 and EN 1993-1-11 should be followed for anchorages.

2.7 Driveability

(1)P In the design of all piles (bearing piles or sheet piles), the practical aspects of installing the piles to the required penetration depth shall be taken into account. Reference shall be made to EN 12063 and to EN 12699 and EN 14199.

(2) The type, size and detailing of the piles should be chosen, in combination with the effectiveness of the piling plant used for installation and extraction, and the driving procedure (driving parameters), to be suitable for the ground conditions through which the piles have to be driven.

(3) If pile points, stiffeners or friction reducers are used as an aid to driving or to strengthen the piles during installation, their effects on the performance of the piles under service conditions should be taken into account.

3 Material properties

3.1 General

(1)P This Part 5 of EN 1993 shall be used for the design of piles and retaining walls fabricated from steel conforming with the standards referred to in 3.2 to 3.9.

(2) This document may also be used for other structural steels, provided that adequate data exist to justify application of the relevant design and fabrication rules. Test procedures and test evaluation should conform with section 2 of EN 1993-1-1 and EN 1990 and the test requirements should align with those given in the relevant standards mentioned in 3.2 to 3.9.

(3)P Re-used and second quality piles shall as a minimum comply with the requirements concerning geometrical and material properties specified in the design and shall be free from damage and deleterious matters that would affect strength and durability.

3.2 Bearing piles

(1) Reference should be made to EN 1993-1-1 for steel properties.

(2) For the properties of steel piles fabricated from steel sheet piles see 3.3 or 3.4.

3.3 Hot rolled steel sheet piles

(1)P Hot rolled steel sheet piles shall be in accordance with EN 10248.

(2) Nominal values of the yield strength f_y and the ultimate tensile strength f_u for hot rolled steel sheet piles may be obtained from Table 3-1, which are the minimum values given in EN 10248-1.

(3) Reference should be made to 3.2.2 of EN 1993-1-1 for ductility requirements.

NOTE: The steel grades listed in Table 3-1 are accepted as satisfying these requirements.

Table 3-1: Nominal values of yield strength f_y and ultimate tensile strength f_u for hot rolled steel sheet piles according to EN 10248-1

Steel name to EN 10027	f_y [N/mm ²]	f_u [N/mm ²]
S240 GP	240	340
S270 GP	270	410
S320 GP	320	440
S355 GP	355	480
S390 GP	390	490
S430 GP	430	510

3.4 Cold formed steel sheet piles

(1)P Cold formed steel sheet piles shall be in accordance with EN 10249.

(2) Nominal values for the basic yield strength f_{yb} and the ultimate tensile strength f_u for cold formed steel sheet piles may be obtained from Table 3-2 which is in accordance with EN 10249-1.

NOTE: The basic yield strength f_{yb} is the nominal yield strength of the basic steel used for cold forming.

(3) Reference should be made to A.3.1 for ductility requirements.

Table 3-2: Nominal values of basic yield strength f_{yb} and ultimate tensile strength f_u for cold formed steel sheet piles according to EN 10249-1

Steel name to EN 10027	f_{yb} [N/mm ²]	f_u [N/mm ²]
S235 JRC	235	340
S275 JRC	275	410
S355 JOC	355	490

3.5 Sections used for waling and bracing

(1) Reference should be made to 3.1 and 3.2 of EN 1993-1-1 for properties of steels used for walings and bracing.

3.6 Connecting devices

(1) Reference should be made to EN 1993-1-8 for properties of bolts, nuts and washers and of welding consumables.

3.7 Steel members used for anchors

(1) Reference should be made to EN 1537 for anchors made from high strength steel with a specified minimum yield strength $f_{y,spec}$, which should not be higher than $f_{y,spec,max}$.

NOTE: The value $f_{y,spec,max}$ may be given in the National Annex. The value $f_{y,spec,max} = 500$ N/mm² is recommended.

(2) Reference should be made to 3.2.1, 3.2.2 of EN 1993-1-1 and 3.9 of EN 1993-5 for the material properties of anchors made of non-high strength steel.

3.8 Steel members used for combined walls

(1)P Steel properties of special I-section piles used as the primary elements of combined walls shall be in accordance with EN 10248.

(2)P Tubes used as the primary elements in combined walls shall conform with EN 10210 or EN 10219.

(3) Steel properties of built up box piles used as the primary elements of combined walls should satisfy the requirements given in 3.2.

(4) Steel properties of the secondary elements used for combined walls should satisfy the requirements given in 3.3 or 3.4 respectively.

(5)P Hot rolled connecting devices for sheet piles shall be in accordance with EN 10248.

3.9 Fracture toughness

(1)P The material shall have sufficient toughness to avoid brittle fracture at the lowest service temperature expected to occur within the intended life of the structure.

NOTE: The lowest service temperature to be taken into account may be given in the National Annex.

(2) For sheet piling with a flange thickness not more than 25mm, steels with values of T_{27J} according to Table 3-3 may be used, provided that the lowest service temperature is not lower than -30°C .

NOTE 1: For other cases reference can be made to EN 1993-1-10.

NOTE 2: The T_{27J} value is the test temperature at which an impact energy $K_V(T) > 27$ Joule is required to fracture a Charpy-V-notch specimen. For the test see EN 10045.

Table 3-3: Test temperature T_{27J} for fracture toughness of steel piles

Yield strength f_y [N/mm^2]		240	270	320	355	390	430
Values of T_{27J}	for lowest service temperature of -15°C	35°	35°	35°	15°	15°	15°
	for lowest service temperature of -30°C	20°	20°	20°	0°	0°	0°

Notes:

1) If there are holes (e.g. for anchors) in a flange stressed in tension, the reduction of the cross-sectional resistance should be taken into account by using a reduced yield strength or an effective cross-sectional area.

2) These values have been calculated for a lowest service temperature and a flange thickness of not more than 25mm without taking into account dynamic effects. For a flange thickness $25 < t_f \leq 30$ mm the values given in the table for T_{27J} should be reduced by 5° for lowest service temperature of -15°C and by 10° for lowest service temperature of -30°C .

3) Higher toughness requirements may be necessary if driving of the piles is foreseen in hard soils at temperatures below -10°C .

4 Durability

4.1 General

(1)P Dependant upon the aggressiveness of the media surrounding the steel member, measures against corrosion effects shall be taken into account if substantial losses of steel thickness are to be expected.

(2) If corrosion is to be taken into account in the design by a reduction of thickness, reference should be made to 4.4.

(3) Consideration should be given to the following measures to prolong the life of the structure:

- the use of additional steel thickness as a corrosion allowance;
- statical reserve;
- the use of protective coatings (usually paints, grouting or galvanizing);
- the use of cathodic protection, with or without protective coatings;
- providing a concrete, mortar or grout protection in the zone of high corrosion.

(4) If the required design working life is longer than the duration of the protective effect of a coating, the loss of thickness occurring during the remaining design working life should be taken into account in serviceability limit state and ultimate limit state verifications.

NOTE 1: A combination of different protective measures may be useful to obtain a high design working life. The whole protective system can be defined taking into account the design of the structure and of the protective coating as well as the feasibility of inspection.

NOTE 2: Special care is necessary in areas where poorly isolated sources of direct current are likely to produce stray currents in the soil.

(5) The possibility that corrosion may not be uniform over the whole length of a pile may be taken into account, allowing an economic design to be achieved by selection of a moment distribution adapted to the corrosion distribution, see Figure 4-1.

(6) The required design working life for sheet piling and bearing piles should be given for each project.

(7) The loss of thickness due to corrosion may be neglected for a required design working life of less than 4 years, unless a different period is given for the project

(8) Corrosion protection systems should be defined for each project.

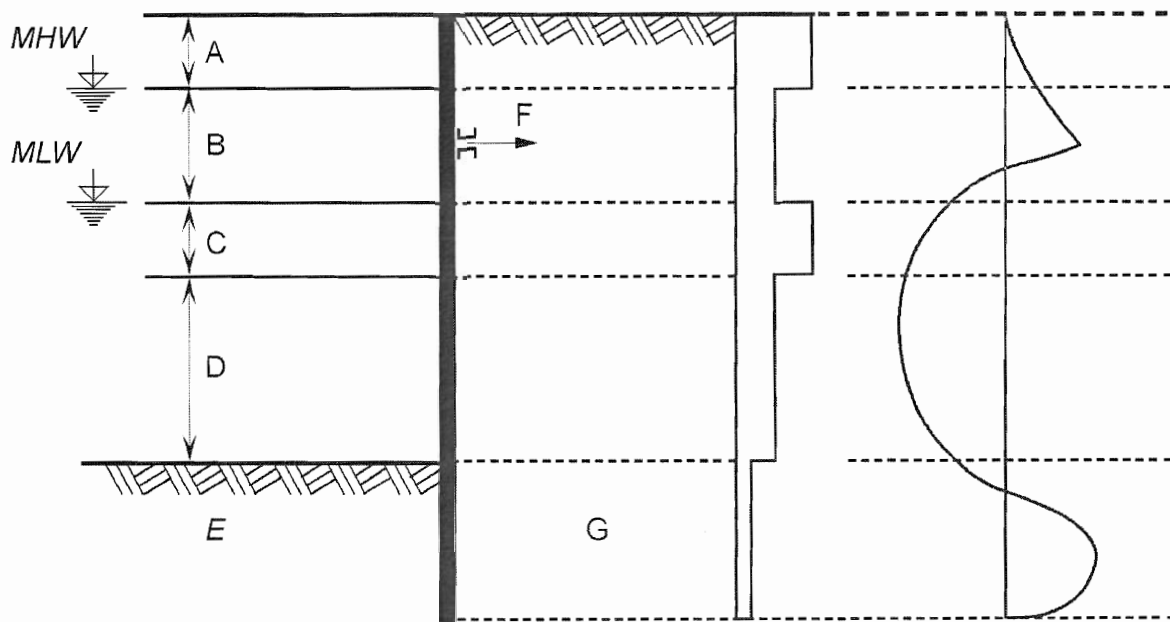

a) Vertical zoning of sea water aggressivity

b) Corrosion rate distribution at side exposed to sea water

c) Typical bending moment distribution

A	Zone of high attack (splash zone);	B	Intertidal zone;
C	Zone of high attack (Low water zone);	D	Permanent immersion zone;
E	Buried zone (Water side);	F	Anchor;
G	Buried zone (Soil side)		
MHW	Mean high water;	MLW	Mean low water

NOTE: Corrosion rate distribution and zones of sea water aggressivity may vary considerably from the example shown in Figure 4-1, dependant upon the conditions prevailing at the location of the structure.

Figure 4-1: Example of corrosion rate distribution

4.2 Durability requirements for bearing piles

- (1) Unless otherwise specified, the strength verification of individual piles for both serviceability and ultimate limit state should be carried out taking into account a uniform loss of steel thickness all around the perimeter of the cross-section.
- (2) Unless otherwise specified, for serviceability and ultimate limit states the reduction of thickness due to corrosion of piles in contact with water or with soil (with or without groundwater) should be taken from section 4.4, dependant upon the required design working life of the structure.
- (3) Unless otherwise specified for the project, corrosion inside hollow piles that have watertight closed ends, or are filled with concrete, may be neglected.

4.3 Durability requirements for sheet piling

(1) Unless otherwise specified, in the strength verification of sheet piles for both serviceability and ultimate limit states, the loss of thickness for parts of sheet pile walls in contact with water or with soil (with or without groundwater) should be taken from section 4.4, dependant upon the required design working life of the structure. Where sheet piles are in contact with soil or water on both sides, the corrosion rates apply to each side.

(2) If the aggressiveness of the soil or water is different on opposite sides of a sheet pile wall, two different corrosion rates may be applied.

4.4 Corrosion rates for design

(1) Corrosion rates given in this section should be considered as for design only.

NOTE: Suitable values for corrosion rates may be given in the National Annex, taking into account local conditions. Values that may be used for guidance are given in Table 4-1 and Table 4-2.

(2) The loss of thickness due to atmospheric corrosion may be taken as 0,01 mm per year in normal atmospheres and as 0,02 mm per year in locations where marine conditions may affect the performance of the structure.

NOTE: The following have a major influence on the corrosion rates in soils:

- the type of soil;
- the variation of the level of the groundwater table;
- the presence of oxygen;
- the presence of contaminants.

Table 4-1: Recommended value for the loss of thickness [mm] due to corrosion for piles and sheet piles in soils, with or without groundwater

Required design working life	5 years	25 years	50 years	75 years	100 years
Undisturbed natural soils (sand, silt, clay, schist, ...)	0,00	0,30	0,60	0,90	1,20
Polluted natural soils and industrial sites	0,15	0,75	1,50	2,25	3,00
Aggressive natural soils (swamp, marsh, peat, ...)	0,20	1,00	1,75	2,50	3,25
Non-compacted and non-aggressive fills (clay, schist, sand, silt,)	0,18	0,70	1,20	1,70	2,20
Non-compacted and aggressive fills (ashes, slag,)	0,50	2,00	3,25	4,50	5,75

Notes:

1) Corrosion rates in compacted fills are lower than those in non-compacted ones. In compacted fills the figures in the table should be divided by two.

2) The values given for 5 and 25 years are based on measurements, whereas the other values are extrapolated.

Table 4-2: Recommended value for the loss of thickness [mm] due to corrosion for piles and sheet piles in fresh water or in sea water

Required design working life	5 years	25 years	50 years	75 years	100 years
Common fresh water (river, ship canal,) in the zone of high attack (water line)	0,15	0,55	0,90	1,15	1,40
Very polluted fresh water (sewage, industrial effluent,) in the zone of high attack (water line)	0,30	1,30	2,30	3,30	4,30
Sea water in temperate climate in the zone of high attack (low water and splash zones)	0,55	1,90	3,75	5,60	7,50
Sea water in temperate climate in the zone of permanent immersion or in the intertidal zone	0,25	0,90	1,75	2,60	3,50

Notes:

- 1) The highest corrosion rate is usually found in the splash zone or at the low water level in tidal waters. However, in most cases, the highest bending stresses occur in the permanent immersion zone, see Figure 4-1.
- 2) The values given for 5 and 25 years are based on measurements, whereas the other values are extrapolated.

5 Ultimate limit states

5.1 Basis

5.1.1 General

- (1)P Piles and their components shall be designed such that the basic design requirements for ultimate limit states given in section 2 are satisfied.
- (2) The following provisions should be applied for the verification of the resistances of cross-sections and members with respect to ultimate limit states.
- (3) Reference should be made to EN 1990 for the partial factors for actions and the method for combining actions to be applied.
- (4) For the partial factors γ_{M0} , γ_{M1} and γ_{M2} to be applied to resistance see EN 1993-1-1.

NOTE: The partial factors γ_{M0} , γ_{M1} and γ_{M2} for piling may be chosen in the National Annex. The following values are recommended: $\gamma_{M0} = 1,00$; $\gamma_{M1} = 1,10$ and $\gamma_{M2} = 1,25$.

5.1.2 Design

- (1) Retaining walls and bearing piles should be checked for:
 - resistance of the cross-section and overall buckling of sheet piling (see 5.2) and of bearing piles (see 5.3);
 - the resistance of walings, bracing, connections and anchors (see section 7);
 - global failure of the structure as a result of soil failure (see section 2).

5.1.3 Fatigue

- (1) Where a structure or a part of it is sensitive to fatigue phenomena, the fatigue assessment should be carried out in accordance with EN 1993-1-9.

NOTE: The fatigue resistance is significantly influenced by corrosion and a suitable corrosion protection is recommended.

- (2) The effects of impact or vibration during installation of bearing piles or sheet piles may be neglected in fatigue analysis.

5.2 Sheet piling

5.2.1 Classification of cross-sections

- (1)P If elastic global analysis is used, it shall be verified that the maximum effects of actions do not exceed the corresponding resistances.
- (2)P If plastic global analysis is used, it shall be verified that the maximum effects of actions do not exceed the plastic resistance of the steel pile. In addition, the rotation capacity shall be checked, see Table 5-1.

(3) The analysis method for the distribution of effects of actions should be consistent with the following classification of cross-sections:

- Class 1 cross-sections for which a plastic analysis involving moment redistribution may be carried out, provided that they have sufficient rotation capacity;
- Class 2 cross-sections for which elastic global analysis is necessary, but advantage can be taken of the plastic resistance of the cross-section;
- Class 3 cross-sections which should be designed using an elastic global analysis and an elastic distribution of stresses over the cross-section, allowing yielding at the extreme fibres;
- Class 4 cross-sections for which local buckling affects the cross-sectional resistance, see Annex A.

(4) The limiting proportions for class 1, 2 and 3 cross-sections may be obtained from Table 5-1 for steel sheet piles, taking into account a possible reduction of steel thickness due to corrosion.

NOTE: Further guidance on the classification of cross-sections is given in Annex C.

(5) An element which fails to satisfy the limits for class 1, 2 or 3 should be taken as class 4.

(6)P The effects of actions in other structural elements and connections shall not exceed the resistances of those elements and connections.

Table 5-1: Classification of cross-sections

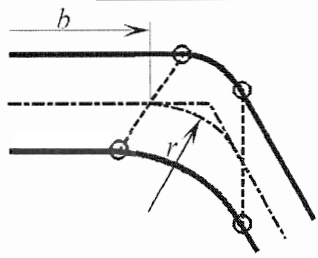
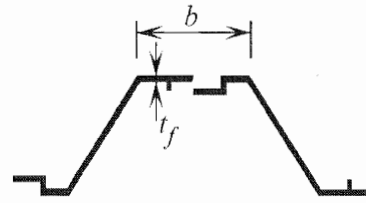
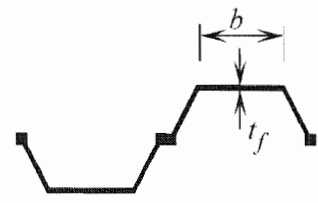
Classification		Z-profile				U-profile		
								
Class 1		<ul style="list-style-type: none"> - the same boundaries as for class 2 apply - a rotation check has to be carried out 						
Class 2		$\frac{b/t_f}{\epsilon} \leq 45$				$\frac{b/t_f}{\epsilon} \leq 37$		
Class 3		$\frac{b/t_f}{\epsilon} \leq 66$				$\frac{b/t_f}{\epsilon} \leq 49$		
$\epsilon = \sqrt{\frac{235}{f_y}}$	f_y [N/mm ²]	240	270	320	355	390	430	
	ϵ	0,99	0,93	0,86	0,81	0,78	0,74	
<p>Key:</p> <p><i>b</i>: width of the flat portion of the flange, measured between the corner radii, provided that the ratio r/t_f is not greater than 5,0; otherwise a more precise approach should be used;</p> <p><i>t_f</i>: thickness of the flange for flanges with constant thickness;</p> <p><i>r</i>: midline radius of the corners between the webs and the flanges;</p> <p><i>f_y</i>: yield strength.</p> <p>Note: For class 1 cross-sections it should be verified that the plastic rotation provided by the cross-section is not less than the plastic rotation required in the actual design case. Guidance for this verification (rotation check) is given in Annex C.</p>								

5.2.2 Sheet piling in bending and shear

(1) In the absence of shear and axial force, the design value of the bending moment M_{Ed} at each cross-section should satisfy:

$$M_{Ed} \leq M_{c,Rd} \tag{5.1}$$

where:

M_{Ed} is the design bending moment, derived from a calculation according to the relevant case of EN 1997-1;

$M_{c,Rd}$ is the design moment resistance of the cross-section.

(2) The design moment resistance of the cross-section $M_{c,Rd}$ should be determined from the following:

- Class 1 or 2 cross-sections: $M_{c,Rd} = \beta_B W_{pl} f_y / \gamma_{M0}$ (5.2)

- Class 3 cross-sections: $M_{c,Rd} = \beta_B W_{el} f_y / \gamma_{M0}$ (5.3)

- Class 4 cross-sections: see Annex A.

where:

- W_{el} is the elastic section modulus determined for a continuous wall;
- W_{pl} is the plastic section modulus determined for a continuous wall;
- γ_{M0} partial safety factor according to 5.1.1 (4);
- β_B is a factor that takes account of a possible lack of shear force transmission in the interlocks and has the following values:
 - $\beta_B = 1,0$ for Z-piles and triple U-piles
 - $\beta_B \leq 1,0$ for single and double U-piles.

NOTE 1: The degree of shear force transmission in the interlocks of U-piles is strongly influenced by:

- the type of soil into which the piles have been driven;
- the type of element installed;
- the number of support levels and their way of fixation in the plane of the wall;
- the method of installation;
- the treatment of the interlocks to be threaded on site (lubricated or partly fixed by welding, a capping beam etc.);
- the cantilever height of the wall (e.g. if the wall is cantilevered to a substantial distance above the highest waling or below the lowest waling).

NOTE 2: The numerical values for β_B for single and double U-piles covering these parameters, based on local design experience, may be given in the National Annex.

- (3) The webs of sheet piles should be verified for shear resistance.
- (4) The design value of the shear force V_{Ed} at each cross-section should satisfy:

$$V_{Ed} \leq V_{pl,Rd} \quad (5.4)$$

where:

$$V_{pl,Rd} \text{ is the design plastic shear resistance for each web given by } \frac{A_v f_y}{\sqrt{3} \gamma_{M0}}; \quad (5.5)$$

A_v is the projected shear area for each web, acting in the same direction as V_{Ed} .

- (5) The projected shear area A_v may be taken as follows for each web of a U-profile or a Z-profile, see Figure 5-1:

$$A_v = t_w (h - t_f) \quad (5.6)$$

where:

- h is the overall height;
- t_f is the flange thickness;
- t_w is the web thickness. In the case of varying web thicknesses $t_{w,i}$ over the slant height c , excluding the interlocks, t_w in expression (5.6) should be taken as the minimum value of $t_{w,i}$.

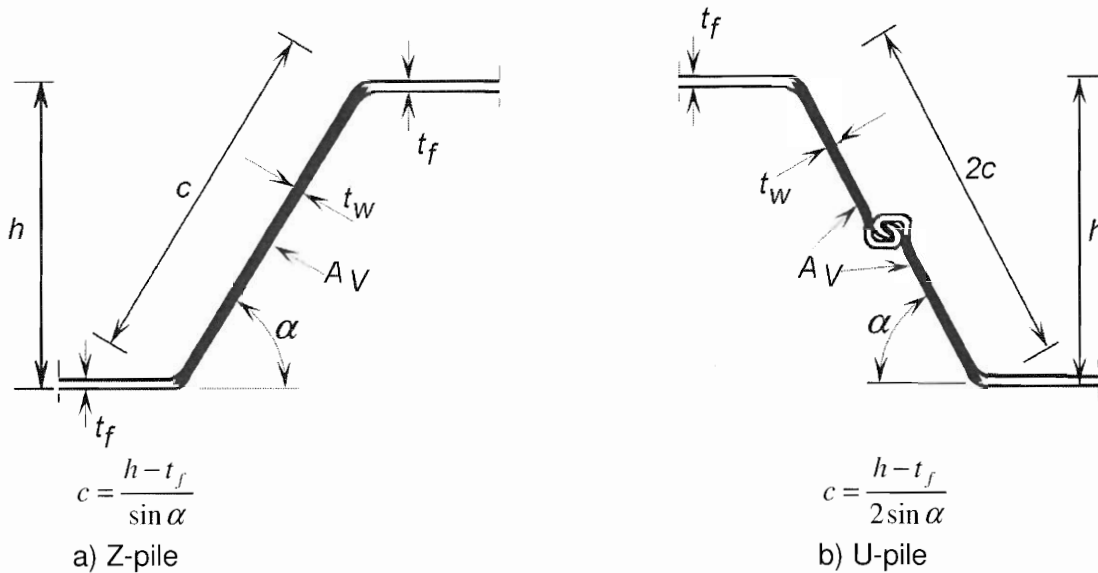

Figure 5-1: Definition of the shear area

- (6) In addition the shear buckling resistance of the webs of sheet piles should be verified if

$$c/t_w > 72 \varepsilon.$$

- (7) The shear buckling resistance should be obtained from:

$$V_{b,Rd} = \frac{(h - t_f)t_w f_{bv}}{\gamma_{M0}} \quad (5.7)$$

where $f_{b,v}$ is the shear buckling strength according to Table 6-1 of EN 1993-1-3 for a web without stiffening at the support and for a relative web slenderness given by:

$$\bar{\lambda} = 0.346 \frac{c}{t_w} \sqrt{\frac{f_y}{E}} \quad (5.8)$$

- (8) Provided that the design value of the shear force V_{Ed} does not exceed 50% of the design plastic shear resistance $V_{pl,Rd}$ no reduction need be made in the design moment resistance $M_{c,Rd}$.

- (9) When V_{Ed} exceeds 50% of $V_{pl,Rd}$ the design moment resistance of the cross-section should be reduced to $M_{V,Rd}$, the reduced design plastic moment resistance allowing for the shear force, obtained as follows:

$$M_{V,Rd} = \left[\beta_B W_{pl} - \frac{\rho A_V^2}{4t_w \sin \alpha} \right] \frac{f_y}{\gamma_{M0}} \quad \text{but} \quad M_{V,Rd} \leq M_{c,Rd} \quad (5.9)$$

with:

$$\rho = (2 V_{Ed} / V_{pl,Rd} - 1)^2 \quad (5.10)$$

where:

- A_v is the shear area according to (5.6);
- t_w is the web thickness;
- α is the inclination of the web according to Figure 5-1;
- β_B is the factor defined in 5.2.2(2).

NOTE: A_v and t_w are related to the width considered for W_{pl} .

(10) If steel sheet piling made of U-piles has been connected by welding or by crimping in order to enhance the shear force transmission in these interlocks, the connections should be verified assuming that the shear force can be transferred only in the connected interlocks.

NOTE: This assumption allows for a safe-sided design of the connections.

(11) The verification of the butt welds for the transmission of the shear force should be in accordance with 4.7 of EN 1993-1-8.

(12) The layout of the butt welds should be in accordance with 4.3 of EN 1993-1-8 taking into account corrosion if relevant.

(13) In the case of intermittent butt welds, a length of not less than l should be made continuous at each end of the pile in order to avoid possible overstressing during installation. Reference should be made to 1993-1-8 for the design of the welds.

NOTE: The value l may be given in the National Annex. A value of $l = 500$ mm is recommended.

(14)P It shall be verified that the crimped points of interlocks are able to transmit the resulting interlock shear forces.

(15) Provided that the spacing of the single or double crimped points does not exceed 0,7 m and the spacing of triple crimped points does not exceed 1,0 m, each crimped point may be assumed to transmit an equal shear force $V_{Ed} \leq R_k / \gamma_{M0}$ where R_k is the characteristic resistance of the crimped point determined by testing in accordance with section 2.6.

NOTE: For the determination of R_k by testing see EN 10248.

5.2.3 Sheet piling with bending, shear and axial force

(1) For combined bending and compression, member buckling need not be taken into account if:

$$\frac{N_{Ed}}{N_{cr}} \leq 0,04 \quad (5.11)$$

where:

- N_{Ed} is the design value of the compression force;

N_{cr} is the elastic critical load of the sheet pile, calculated with an appropriate soil model, taking into account only compression forces in the sheet pile.

(2) Alternatively N_{cr} may be taken as:

$$N_{cr} = EI \beta_D \pi^2 / \ell^2 \quad (5.12)$$

in which ℓ is the buckling length, determined according to Figure 5-2 for a free or partially fixed earth support or according to Figure 5-3 for a fixed earth support and β_D is a reduction factor, see 6.4.

(3) If the criterion given in (1) is not satisfied, the buckling resistance should be verified.

NOTE: This verification can be carried out using the procedure given in (4) to (7).

(4) Provided that the boundary conditions are supplied by elements (anchor, earth support, capping beam etc.) that give positional restraint corresponding to the non-sway buckling mode, the following simplified buckling check may be used:

- for class 1, 2 and 3 sections:

$$\frac{N_{Ed}}{\chi N_{pl,Rd} (\gamma_{M0} / \gamma_{M1})} + 1,15 \frac{M_{Ed}}{M_{c,Rd} (\gamma_{M0} / \gamma_{M1})} \leq 1,0 \quad (5.13)$$

where:

$N_{pl,Rd}$ is the plastic design resistance of the cross-section ($A f_y / \gamma_{M0}$);

$M_{c,Rd}$ is the design moment resistance of the cross-section, see 5.2.2 (2);

γ_{M1} is the partial factor according to 5.1.1 (4);

γ_{M0} is the partial factor according to 5.1.1 (4);

χ is the buckling coefficient from 6.3.1.2 of EN 1993-1-1, using curve d and a non dimensional slenderness given by:

$$\bar{\lambda} = \sqrt{\frac{A f_y}{N_{cr}}}$$

with:

N_{cr} is the elastic critical load, which may be determined according to (5.12);

A is the cross-sectional area;

- for class 4-sections: see Annex A.

NOTE: Buckling curve *d* also covers driving imperfections up to 0,5% of ℓ which is considered to be good practice.

(5) For the simplified approach the buckling length ℓ may be determined as follows, assuming a non-sway buckling mode according to (7):

- for a free earth support, provided that sufficient restraint exists according to (6), ℓ may be taken as the distance between the toe and the horizontal support (waling, anchor), see Figure 5-2;

- for a fixed earth support ℓ may be taken as 70 % of the distance between the toe and the horizontal support (waling, anchor), see Figure 5-3.

(6) It may be assumed that a free earth support provides sufficient restraint for the simplified approach if the toe of the sheet pile wall is fixed in bedrock or if the toe of the sheet pile wall is able to resist an additional horizontal force $F_{Q,Ed}$ by passive earth pressure or by friction according to Figure 5-4. $F_{Q,Ed}$ is given by:

$$F_{Q,Ed} = \pi N_{Ed} \left(\frac{d}{\ell} + 0,01 \right) \quad (5.14)$$

where d is the maximum relative deflection of the sheet pile wall occurring between the supports according to a first order analysis. The force $F_{Q,Ed}$ can be resisted by providing AC1 an additional pile length Δh according AC1 to Figure 5-4 if the soil resistance is fully mobilised in the absence of friction.

(7) If the supplementary displacement of a horizontal support (anchor, waling) due to a support load of $N_{Ed}/100$ is less than $\ell/500$, the support may be assumed to provide enough restraint for the assumption of a non-sway buckling mode.

(8) If the system does not provide enough restraint, a detailed buckling investigation should be carried out, based on the methods given in EN 1993-1-1.

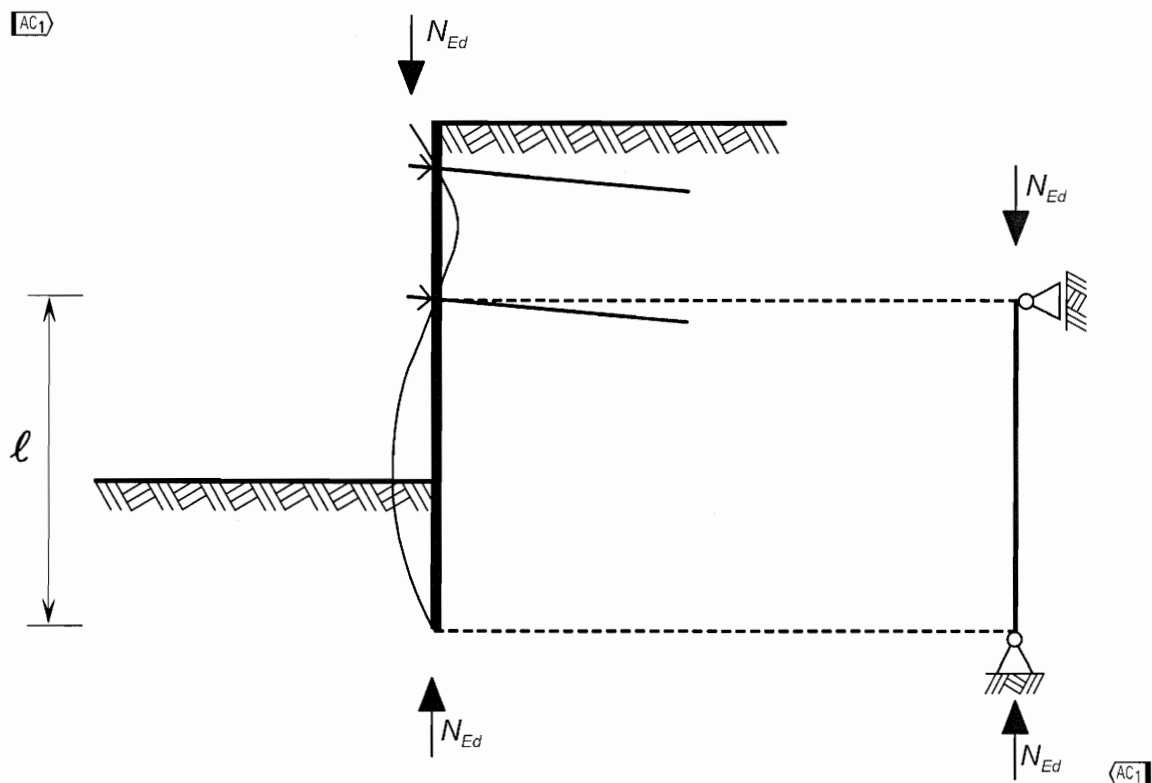

Figure 5-2: Possible determination of buckling length ℓ , free earth support

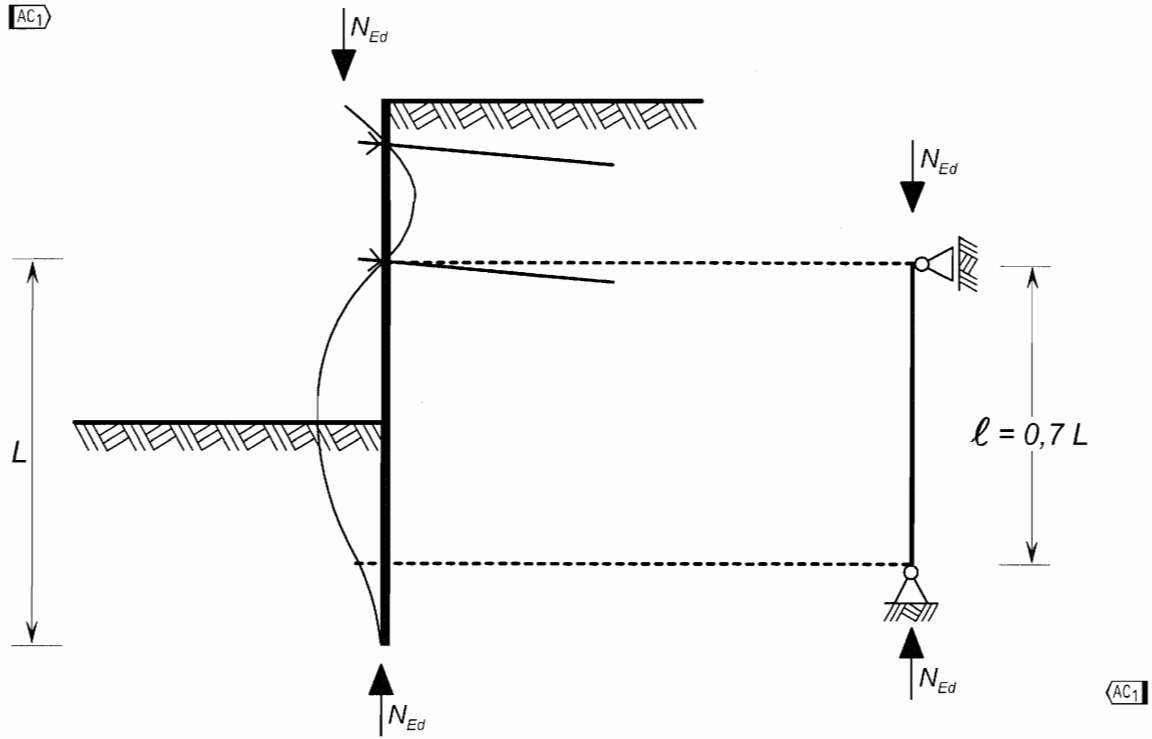
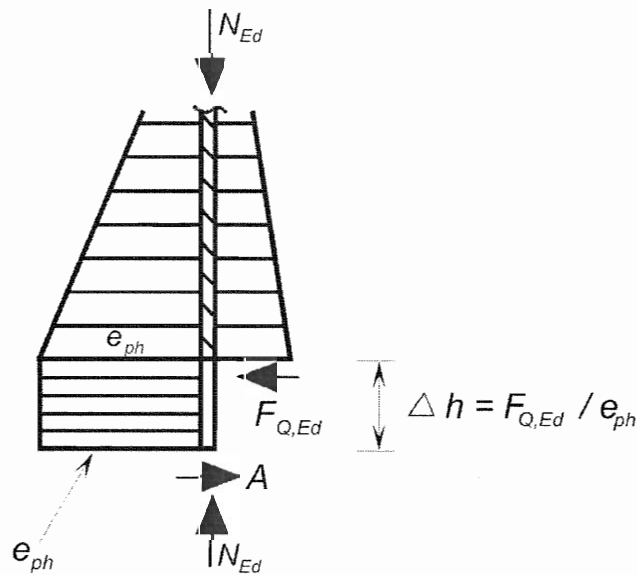

Figure 5-3: Possible determination of buckling length l , fixed earth support



e_{ph} Horizontal passive earth pressure

A Friction force

Figure 5-4: Determination of supplementary horizontal force $F_{Q,Ed}$

(9) For members subject to axial force, the design value of the axial force N_{Ed} at each cross-section should satisfy:

$$N_{Ed} \leq N_{pl,Rd} \quad (5.15)$$

in which $N_{pl,Rd}$ is the plastic design resistance of the cross-section with:

$$N_{pl,Rd} = A f_y / \gamma_{M0} \quad (5.16)$$

(10) The effects of axial force on the plastic moment resistance of the cross-section of class 1, 2 and 3 sheet piles may be neglected if:

- for Z-profiles of class 1 and 2:

$$\frac{N_{Ed}}{N_{pl,Rd}} \leq 0,1 \quad (5.17)$$

- for U-profiles of class 1 and 2:

$$\frac{N_{Ed}}{N_{pl,Rd}} \leq 0,25 \quad (5.18)$$

- for class 3 profiles:

$$\frac{N_{Ed}}{N_{pl,Rd}} \leq 0,1 \quad (5.19)$$

(11) If the axial force exceeds the limiting values given in (10), the following criteria should be satisfied in the absence of shear force:

- Class 1 and 2 cross-sections:

- for Z-profiles:

$$M_{N,Rd} = 1,11 M_{c,Rd} (1 - N_{Ed} / N_{pl,Rd}) \quad \text{but} \quad M_{N,Rd} \leq M_{c,Rd} \quad (5.20)$$

- for U-profiles:

$$M_{N,Rd} = 1,33 M_{c,Rd} (1 - N_{Ed} / N_{pl,Rd}) \quad \text{but} \quad M_{N,Rd} \leq M_{c,Rd} \quad (5.21)$$

- Class 3 cross-sections:

$$M_{N,Rd} = M_{c,Rd} (1 - N_{Ed} / N_{pl,Rd}) \quad (5.22)$$

- Class 4 cross-sections: see Annex A.

where:

$M_{N,Rd}$ is the reduced design moment resistance allowing for the axial force.

(12) If the axial force exceeds the limiting value given in (10), account should be taken of the combined presence of bending, axial and shear force as follows:

a) Provided that the design value of the shear force V_{Ed} does not exceed 50% of the design plastic shear resistance $V_{pl,Rd}$ no reduction need be made in combinations of moment and axial force that satisfy the criteria in (11).

b) When V_{Ed} exceeds 50% of $V_{pl,Rd}$ the design resistance of the cross-section to combinations of moment and axial force should be calculated using a reduced yield strength $f_{y,red} = (1 - \rho) f_y$ for the shear area, where $\rho = (2 V_{Ed} / V_{pl,Rd} - 1)^2$.

5.2.4 Local effects of water pressure

(1) In the case of differential water pressure exceeding 5 m head for Z-piles and 20 m head for U-piles the effects of water pressure on transverse local plate bending should be taken into account to determine the overall bending resistance.

(2) As a simplification, this verification may be carried out for Z-piles using the following procedure:

- if the differential water pressure is more than 5 m head, the cross-sectional verification should be carried out at the locations of the maximum overall bending moments;
- the effect of differential water pressure should be taken into account by using a reduced yield strength

$$f_{y,red} = \rho_p f_y$$

with ρ_p taken from Table 5-2, for the determination of the cross-sectional resistance;

- to determine ρ_p from Table 5-2 the differential water pressure acting at the relevant locations of maximum moment should be taken into account.

Table 5-2: Reduction factors ρ_p for Z-piles due to differential water pressure

w	$(b/t_{min}) \varepsilon = 20,0$	$(b/t_{min}) \varepsilon = 30,0$	$(b/t_{min}) \varepsilon = 40,0$	$(b/t_{min}) \varepsilon = 50,0$
5,0	1,00	1,00	1,00	1,00
10,0	0,99	0,97	0,95	0,87
15,0	0,98	0,96	0,92	0,76
20,0	0,98	0,94	0,88	0,60

Key:

b is the width of the flange, but b should not be taken as less than $c/\sqrt{2}$, where c is the slant height of the web
 t_{min} is the lesser of t_f or t_w
 t_f is the flange thickness
 t_w is the web thickness
 w is the differential head in m

$$\varepsilon = \sqrt{\frac{235}{f_y}}; f_y \text{ is the yield strength in N/mm}^2.$$

Notes:

- 1) $\rho_p = 1,0$ may be used if the interlocks of Z-piles are welded.
- 2) Intermediate values may be interpolated linearly.

5.2.5 Straight web steel sheet piles

(1)P The effects of actions for strength verification of straight web steel sheet piles used in cellular structures, shall be determined from a model that describes the behaviour of the piling at ultimate limit states.

(2) Reference should be made to EN 1997-1 and to EN 1990 for partial factors to be applied to the fill and the actions.

(3) The fill model should be in accordance with EN 1997-1.

(4) The piling model should be in accordance with EN 1993-1-1.

NOTE: It can be beneficial to use models taking into account large displacements for the piling.

(5) A two-dimensional analysis in the governing horizontal plane may be used.

(6) The internal pressure resulting from or transmitted through the fill should be determined using a value not less than the at rest value of the earth pressure, see EN 1997-1.

(7) The tensile resistance $F_{ts,Rd}$ of plain straight web steel sheet piles, (other than junction piles) should be taken as the lesser of the interlock resistance and the resistance of the web, using:

$$F_{ts,Rd} = \beta_R R_{k,s} / \gamma_{M0} \quad \text{but} \quad F_{ts,Rd} \leq t_w f_y / \gamma_{M0} \quad (5.23)$$

where:

f_y is the yield strength;

$R_{k,s}$ is the characteristic interlock resistance;

t_w is the web thickness;

β_R is the reduction factor for interlock resistance.

NOTE: The value β_R may be given in the National Annex. The value $\beta_R = 0,8$ is recommended.

(8) The characteristic resistance of the interlock $R_{k,s}$ depends upon the cross-section of the interlock and the steel grade adopted. The characteristic interlock resistance $R_{k,s}$ should be determined by testing according to 2.6 and EN 10248.

(9) Plain piles should be verified such that:

$$F_{t,Ed} \leq F_{ts,Rd} \quad (5.24)$$

where:

$F_{ts,Rd}$ is the design tensile resistance according to expression (5.23);

$F_{t,Ed}$ is the design value of the circumferential tensile force.

(10) When piles of different sizes are used in the same segment of a wall, the lowest tensile resistance should be used for the verification.

- (11) The deviation angle (180° minus the angle between two adjacent faces) should be limited to the maximum value given by the manufacturer.
- (12) For welded junction piles, steel grades with appropriate properties should be used.
- (13) The design of junction piles according to Figure 5-5 and Figure 5-6 should take account of the stresses due to plate bending.

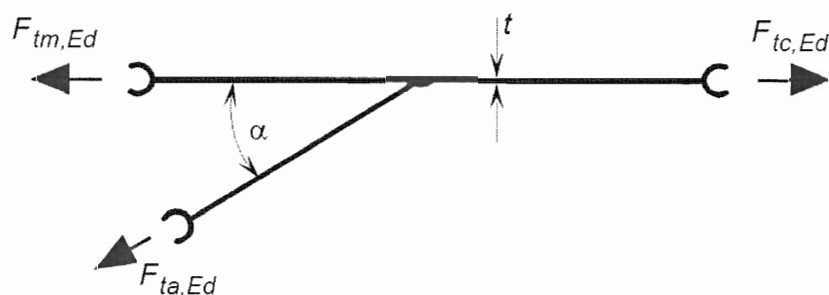

Figure 5-5: Welded junction pile

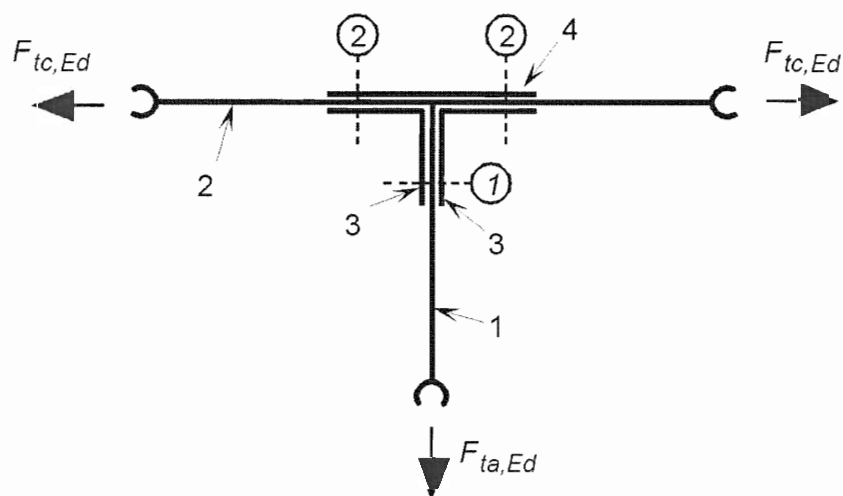

Figure 5-6: Bolted T-connection with backing plate

- (14) Provided that welding is carried out according to the procedure given in EN 12063 the welded junction pile may be verified using:

$$\boxed{\text{AC1}} F_{m,Ed} \leq \beta_T F_{ts,Rd} \quad (5.25) \quad \boxed{\text{AC1}}$$

where:

$F_{ts,Rd}$ is the design tensile resistance of the pile according to expression (5.23);

$\boxed{\text{AC1}} F_{m,Ed}$ is the design tensile force in the main cell given by:

$$F_{m,Ed} = p_{m,Ed} r_m \quad (5.26) \quad \boxed{\text{AC1}}$$

with:

$p_{m,Ed}$ is the design value of the internal pressure of the main cell in the governing horizontal plane due to water pressure and the at rest pressure of the fill;

r_m is the radius of the main cell, see Figure 5-7.

β_r is a reduction factor that takes into account the behaviour of the welded junction pile at ultimate limit states and should be calculated as follows:

$$\boxed{\text{AC1}} \quad \beta_r = 0,9 (1,3 - 0,8 r_a / r_m) (1 - 0,3 \tan \varphi_k) \quad (5.27) \quad \boxed{\text{AC1}}$$

in which r_a and r_m are the radii of the connecting arc and of the main cell according to Figure 5-7 and $\boxed{\text{AC1}} \varphi_k$ is the characteristic value $\boxed{\text{AC1}}$ of the internal friction angle of the fill material.

NOTE 1: The factor β_r takes into account the rotation capacity (ductility) of the junction pile as well as the rotation demand (up to 20°) according to a model covering the behaviour of the cofferdam at ultimate limit states.

NOTE 2: Expression (5.27) although developed for cellular cofferdams with aligned connecting arcs, see Figure 5-7, yields acceptable results for alternative configurations. Where more appropriate values are required, these values can be determined either by comparable experience or by testing in combination with a suitable design model in accordance with (1)P.

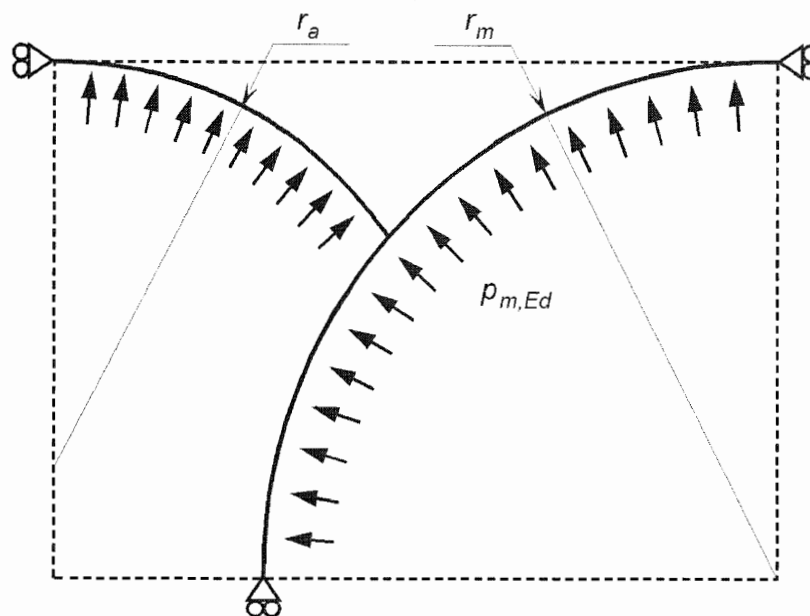

Figure 5-7: Geometry of circular cell and the aligned connecting arc

(15) For a 90° junction pile a bolted T-connection may be used.

(16) For junction piles built up as a bolted T-connection shown in Figure 5-6, the verification may be carried out using the following procedure.

- (17) The interlock strength should be verified according to (9).
- (18) The connections should be verified as follows, see Figure 5-6:
- verification of the shear and bearing resistance of the bolts (1) according to 3.6 of EN 1993-1-8, assuming the tensile force $F_{t1,Ed}$ is equally distributed;
 - verification of the bolt spacing (1) according to 3.5 of EN 1993-1-8;
 - verification of the net cross-section of the web 1 and of the adjacent legs of the angles 3 according to the provisions given in 6.2.5 of EN 1993-1-8;
 - verification of the bolts (2) according to 3.11 of EN 1993-1-8 for their tensile resistance using a T-stub model according to 6.2.4 (mode 3) of EN 1993-1-8;
 - verification of the backing plate 4 and of the adjacent legs of the angles 3 according to the provisions given in 6.2.4 (mode 1 and mode 2) of EN 1993-1-8. In order to permit the use of the design failure modes given in 6.2.4 of EN 1993-1-8, the web of the pile 2 (see Figure 5-6) should be taken as the flange of the equivalent T-stub for modes 1 and 2;
 - verification of the web of the pile 2 for the tensile force $F_{t2,Ed}$ against yielding of the net cross-section.
- (19) Other types of junction piles may be verified accordingly.

5.3 Bearing piles

5.3.1 General

- (1) The effects of actions in piles should be determined in accordance with EN 1997-1, taking account of both equilibrium and compatibility.
- (2) Ultimate limit state verifications should be carried out for failure in the soil for both individual piles and pile groups according to EN 1997, and for failure of the piles and their connections to the structure according to EN 1993-5, EN1992 and EN1994.

5.3.2 Design methods and design considerations

- (1) For piles subjected to axial and transverse loading, the soil resistance should be taken from EN 1997-1.
- (2) The effects of actions in the pile due to transverse forces should be taken into account in combination with those due to axial forces and applied moments. They may be determined by superimposing the results of separate calculations in which the soil in contact with separate portions of the pile length is assumed to be resisting different actions. Alternatively the axial force, bending moments and transverse forces may be considered as resisted by soil over the same length of pile, provided that the soil is capable of resisting their combined effects.
- (3) The structural design of an individual pile should be verified in accordance with section 5 of EN 1993-1-1.
- (4) For axial forces acting at the head of the pile, the distribution of stress may be conservatively taken as constant over the length of the pile for the determination of the effects of actions, except in the case of negative skin friction.

(5) The transmission of torsional moments acting at the head of the pile should not be assumed unless special provisions allow the introduction of the torque into the soil. The distribution of the torque should be taken as constant over the pile length.

5.3.3 Steel piles

(1) Cross sectional verification of steel bearing piles should be in accordance with EN 1993-1-1.

(2) Reference to section 7.8 of EN 1997 may be made for indications of the soil conditions under which overall buckling of piles has to be taken into account.

(3) If the soil provides insufficient lateral restraint, the slenderness criterion for overall buckling may be assumed to be satisfied if $N_{Ed} / N_{cr} \leq 0,10$, where N_{cr} is the critical value of the axial force N_{Ed} .

(4) If overall buckling verification is required reference should be made to section 5 of EN 1993-1-1. The following effects should be taken into account:

- in addition to the imperfections given in 5.3 of EN 1993-1-1 due consideration should be given to supplementary initial imperfections (e.g. due to joints or installation) in accordance with EN 12699 and EN 14199;
- lateral support due to the surrounding soils may be taken into account using an appropriate model (e.g. p-y approach, subgrade reaction model) based on second order theory.

(5) The buckling length may be estimated using the following approach (see Figure 5-8):

$$l_{cr} = k H \quad (5.28)$$

The value k takes into account the connection between the pile head and the concrete deck or the steel structure.

(6) For a more precise determination of the buckling length, for instance for micro piles, reference should be made to 5.3.3 (4).

(7)P Execution shall be in accordance with EN 12699 and EN 14199.

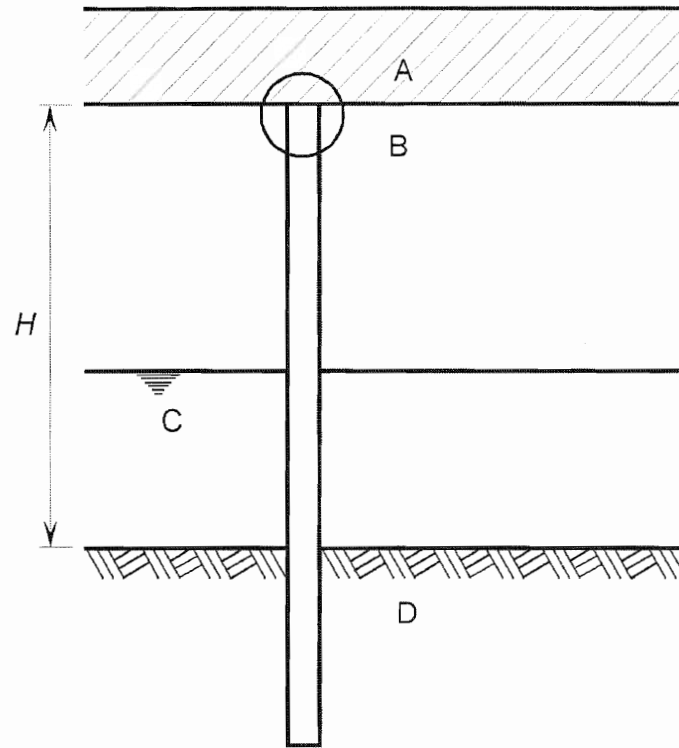

A concrete or steel structure B connection
C water or soft soil D firm soil

$$l_{\text{crit}} = k H \quad \text{with } k = \begin{cases} \boxed{\text{AC}_1} 1,0 & \text{connection B translation fixed and rotation free} \\ 0,7 & \text{connection B translation fixed and rotation fixed} \\ 2,0 & \text{connection B translation free and rotation fixed } \boxed{\text{AC}_1 \end{cases}$$

Figure 5-8: Simplified estimation of buckling length for bearing piles

5.3.4 Steel piles filled with concrete

- (1) Steel piles filled with concrete should be designed in accordance with EN 1994.
- (2) Cross sectional verifications of steel piles filled with concrete should be in accordance with EN 1994-1-1.
- (3) Reference should be made to 5.3.3 and section 6.7 of EN 1994-1-1 for overall buckling verification.
- (4) Concreting of a steel pile should be carried out in accordance with EN 1536, EN 12699 and EN 14199.

5.4 High modulus walls

- (1) The design of high modulus walls should be carried out according to the provision for sheet pile walls, taking into account the specific geometry of the sections used, see Figure 1-6, allowing for local effects due to earth and water pressures and the introduction of anchor and waling forces.

(2) The determination of cross-section resistance may be conservatively based on an elastic analysis of the cross-section, provided that:

- buckling of plate elements is checked using EN 1993-1-5;
- the shear lag effect is taken into account for wide elements.

5.5 Combined walls

5.5.1 General

(1) In the following provisions for the ultimate limit state are given for the following types of combined walls, see Figure 1-5:

- mixed tube and sheet pile walls;
- mixed special I-section and sheet pile walls;
- mixed built-up section and sheet pile walls.

(2) The design of the primary and secondary elements should be based on their functionality:

- the primary elements act as retaining elements against the earth and water pressures and may act as bearing piles for vertical loads;
- the secondary elements only fill the gap between the primary elements and transmit the loads resulting from earth and water pressures to the primary elements.

(3) No transmission of longitudinal shear forces may be taken into account in the free interlocks between primary and secondary elements.

(4)P It should be stated for each project and agreed with the client whether driving imperfections need to be considered in the design of the combined wall. The design values of any driving imperfections shall be given as percentages of the length of the primary elements, assuming a linear distribution.

5.5.2 Secondary elements

(1) Sheet piles used as secondary elements for combined walls should be in accordance with EN 10248.

(2)P For the design of secondary elements, it shall be verified that they are able to transmit the internal forces resulting from earth and water pressures into the primary elements via the connecting devices.

NOTE: It can be advantageous to take into account arching effects leading to a supplementary loading on the primary elements and a reduction of the earth pressures acting on the secondary elements.

(3) The verification according to (2)P may be carried out using a simplified two dimensional frame model for the secondary elements. If required according 5.5.1 (4), driving imperfections should be taken into account in this simplified analysis via the imposed displacement δ using the boundary conditions given in Figure 5-9, which shows a double U-pile as an example of a secondary element.

NOTE: The driving imperfection perpendicular to the plane of the retaining wall is assumed to be absorbed by rotation at the interlocks ("interlock swing").

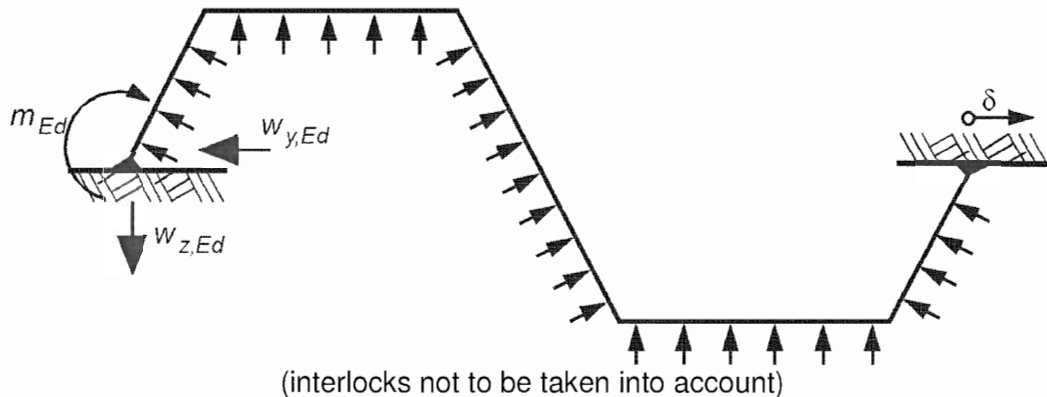

Figure 5-9: Simplified model for secondary elements

(4) For the verification of the cross-section in the simplified frame model, a plastic analysis combined with large displacements may be used. If members of the frame model are stressed in compression, particular attention should be paid to the possibility of instability, such as "snap-through".

(5) Alternatively the verification according to (2)P may be based on the results of testing in accordance with section 2.6.

NOTE: For test evaluation see Annex D of EN 1990.

(6) The test set-up should be able to simulate the behaviour of the intermediate elements.

(7) For sheet piles used as secondary elements, further verification may be omitted if all the following conditions are met:

- wall thickness of the sheet piles: $\geq 10\text{mm}$;
- pressure difference acting on the sheet piles: $\leq 40\text{kN/m}^2$, corresponding to 4 m differential water head;
- maximum clearance between the primary elements is 1,8m for U-piles and 1,5m for Z-piles.

(8) It may be useful to have the secondary elements shorter than the primary elements. Shortening of the secondary elements should be checked according to EN1997-1.

NOTE 1: For shortened secondary elements, care should be taken to avoid underflow in the case of high differential water pressure, or where there is a danger of scour.

NOTE 2: Reference should be made to EN1997-1 for the distribution of passive earth pressure acting on primary elements.

5.5.3 Connecting devices

(1)P The connections between the primary and secondary elements shall be designed to allow the transmission of the design forces from the secondary elements into the primary elements.

(2) This verification may be based on the results of testing in accordance with section 2.6.

- (3) If the verification is carried out by calculation it should be verified that the connections are able to transfer the support reactions determined according to 5.5.2(3).
- (4) Plasticity should be taken into account for the verification of the connecting devices in plate bending.

5.5.4 Primary elements

(1)P The overall effects of actions due to earth and water pressures shall be determined taking into account the loading on both primary and secondary elements and possible supplementary loading due to arching effects in the ground, see 5.5.2(2)P.

(2) Account should be taken of the reduction of the overall resistance of the primary elements due to the forces introduced by the secondary elements via the connecting devices. This requirement may be deemed to be satisfied, if the earth pressure is supposed to act on the primary elements directly, due to the arching effect and if the differential water pressure acting on the secondary elements is $\leq h$ m head.

NOTE: The value h may be given in the National Annex. A value of $h = 5$ m is recommended.

(3) For strength verification of primary elements, unless a more advanced method is used, the design forces from secondary elements introduced via connections, should be taken into account using support reactions determined according to 5.5.2 (3).

(4) The overall resistance may be determined either by testing in accordance with section 2.6 or by calculation as given below.

(5) The verification of I-section or tubular piles should be in accordance with section 5 of EN 1993-1-1.

(6) The effects on the resistance of I-section piles due to the introduction of forces from secondary elements via connections should be taken into account in accordance with EN 1993-1-1.

NOTE: The procedure given in Annex D.1 may be used to determine the reduced overall resistance of I-section piles used as primary elements in combined walls due to the application of the design forces from the secondary elements.

(7) The effects on the resistance of tubular piles due to the introduction of forces from secondary elements via connections should be taken into account in accordance with EN 1993-1-1 and EN 1993-1-6.

NOTE: The procedure given in Annex D.2 may be used to determine the reduced overall resistance for tubular piles used as primary elements in combined walls due to the application of the design loads from the secondary elements.

(8) For the application of concentrated loads via walings, anchors etc. the tubular pile should either be verified accordingly or be provided with stiffeners or be filled with concrete or with high grade compacted, non-cohesive material in order to avoid local buckling.

(9) In the case of a tubular pile that is filled according to (8) the full cross-sectional resistance in accordance with EN 1992, EN 1993 and EN 1994 may be used in the filled part of the tube.

(10) Built-up sections used as primary elements should be verified according to 5.4, provided that due consideration is given to the effect of load application resulting from the secondary elements.

(11) If the simplified approach of 5.4(2) is used, the local effects due to the application of the support reactions determined according to 5.5.2(3) should be taken into account.

6 Serviceability limit states

6.1 Basis

- (1) The significance of settlements and vibrations, and their limiting values in each case, should be given for the project taking into account local conditions.
- (2) The limiting values should be confirmed by a serviceability limit state verification.
- (3) Even if no limiting values are given, it should be verified that plastic deformations do not occur, using a model in accordance with 2.5.3.3 (1).
- (4) The design of sheet piles or bearing piles should be checked at serviceability limit states using appropriate design situations as specified in EN 1997-1, taking into account a possible reduction of steel thickness due to corrosion.

6.2 Displacements of retaining walls

- (1) EN 1997-1 should be taken into account when assessing the displacements of retaining walls.
- (2) Displacements due to the movement of supports (such as walings, bracing, anchorages) should be taken into account.
- (3) If necessary, initial imperfections due to driving should be taken into account in addition to the deformations due to loading based on the driving tolerances indicated in EN 12063.

NOTE: This may be necessary if a particular clearance is required in a cofferdam.

- (4) When assessing the displacements of a sheet pile wall account should be taken of the fact that the quality of the workmanship and supervision during execution has an important influence on the magnitude of those displacements.

6.3 Displacements of bearing piles

- (1) EN 1997-1 should be taken into account when determining the displacements of bearing piles and micro piles.

6.4 Structural aspects of steel sheet piling

- (1) When calculating the displacements of the retaining structure, the possible supplementary displacements due to local deformation at the location of anchors, walings and bracing should be taken into account where their effect is significant.

NOTE: These effects may be relevant if high local transverse forces are introduced into unstiffened jagged walls, see Figure 1-7, through an H-beam used as waling.

- (2)P The effective flexural stiffness shall be taken into account.
- (3) The effective flexural stiffness of sheet piling made of U-piles may be determined as follows, taking into account the degree of shear force transmission in interlocks that are located close to the centroidal axis of the wall:

$$(EI)_{eff} = \beta_D (EI) \quad (6.1)$$

where:

I is the second moment of area of the continuous wall;

β_D is a factor with a value $\leq 1,0$, accounting for the possible reduction due to insufficient shear force transmission in the interlocks.

NOTE 1: β_D depends on many local influences as given in note 1 to 5.2.2(2). The numerical value for β_D may be given in the National Annex.

NOTE 2: The transmission of shear forces in the interlocks of U-piles may be enhanced by connecting the interlocks by continuous or intermittent welding or by crimping.

(4)P Crimped points shall be able to transmit the required interlock shear force. The representative shear force R_{ser} transmitted by a crimped point at serviceability limit state is: $R_{ser} = 75$ kN. It shall be verified by testing, in accordance with EN 10248, that the stiffness of the crimped point is not less than 15 kN/mm.

NOTE 1: This stiffness requirement corresponds to a shear force of 75 kN at a displacement of 5 mm.

NOTE 2: Crimped points may be single, double or triple crimped points.

(5) Provided that the spacing of the single or double crimped points does not exceed 0,7 m (see Figure 6-1) and the spacing of triple crimped point does not exceed 1,0 m, each crimped point may be assumed to transmit an equal shear force $V_{ser} \leq R_{ser}$.

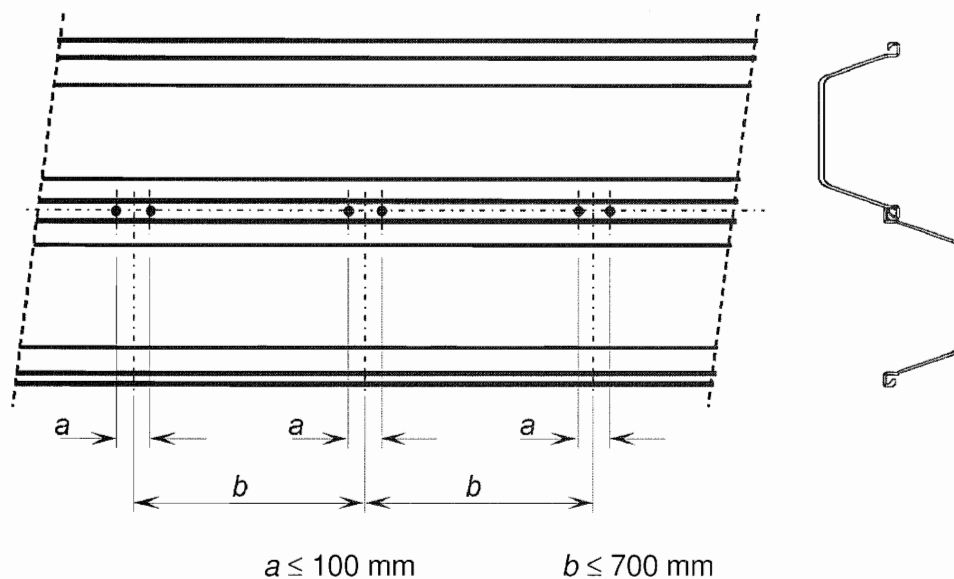

Figure 6-1: Spacing of double crimped points

7 Anchors, walings, bracing and connections

7.1 General

(1)P The effects of actions in anchors, walings, bracing and connections shall be determined from the structural analysis taking into account the interaction between the soil and the structure.

(2) Where necessary, effects of actions such as those due to temperature changes or to specific loads should be taken into account, see 2.5.2 (4).

(3) Appropriate simplified methods of analysis may be used in which the actions applied to the various elements of the structure take account of the behaviour of individual members.

AC1 (4) For partial factor γ_{M2} and $\gamma_{M3,ser}$ to be applied to connections see EN 1993-1-8.

NOTE: The partial factors γ_{Mb} and $\gamma_{M3,ser}$ may be defined in the National Annex. The values $\gamma_{M2} = 1,25$ and $\gamma_{M3,ser} = 1,10$ are recommended. **AC1**

7.2 Anchorages

7.2.1 General

(1)P The verification of the cross-sections and the connections between the steel parts of dead-man anchors, including tie rods, anchor heads or couplers, shall be carried out according to the following.

NOTE: Design provisions for the steel parts of prestressed anchors are given in EN 1537.

(2) The testing procedure and the use of test results for determining the design resistance of dead-man anchors and grouted anchors in respect of pull-out failure of the anchor (soil-structure behaviour), should be in accordance with the principles laid down in EN 1997-1 and EN 1537.

7.2.2 Basic design provisions

(1)P For anchor design, consideration shall be given to both serviceability and ultimate limit states.

(2) The anchor length should be such as to prevent failure of the soil or bond failure before yielding of the minimum required cross-section of the anchor. The anchorage length should be calculated in accordance with EN 1997-1.

(3) For dead-man anchors steel with a specified yield strength not greater than 800 N/mm² should be used.

(4) The axial stiffness of the anchor should be taken into account in the design of the retaining wall. It may be assessed by preliminary testing or from comparable experience.

NOTE: It may be useful to “bracket” the effect of the anchor stiffness on the design of the retaining wall by using a maximum/minimum approach for the stiffness.

7.2.3 Ultimate limit state verification

(1) The tensile resistance $F_{t,Rd}$ of anchors should be taken as the lesser of $F_{t,Rd}$ and $F_{tq,Rd}$.

(2) Unless otherwise specified, the tensile resistance $F_{t,Rd}$ of threads of anchors should be taken as:

$$F_{t1,Rd} = k_t \frac{f_{ua} A_s}{\gamma_{M2}} \quad (7.1)$$

Where:

- A_s is the tensile stress area at the threads;
 f_{ua} is the tensile strength of the steel anchor;
 γ_{M2} is the partial factor according to 7.1 (4).

AC1 **NOTE 1:** k_t may be given in the National Annex. The recommended value for k_t is $k_t = 0,6$. This is motivated for cases where possible bending in the anchor as an effect of actions is not made explicit. Only in cases where the structural detailing of the location where the anchor rod is joined to the wall is such that bending moments are avoided at that location, the recommended value for k_t may be chosen as $k_t = 0,9$. **AC1**

NOTE 2: Conservatively, the net area of the threaded portion can be used instead of the tensile stress area.

- (3) The tensile resistance $F_{t1,Rd}$ of the shaft of an anchor should be taken as

$$F_{t1,Rd} = A_g f_y / \gamma_{M0} \quad (7.2)$$

where:

- A_g is the gross cross-sectional area of the anchor rod.

AC1 Paragraph deleted **AC1**

(4) If the anchors are provided with a dead-man end, or with other load distributing members at their end, no account should be taken of the contribution of bond along the anchor shaft. The whole of the force should be transferred through the load distributing device.

(5) The design tensile resistance of the washer plate assembly $B_{t,Rd}$ should be taken as the lesser of the design tension resistance $F_{t1,Rd}$ given in (3) and the design punching shear resistance of the anchor head and the nut $B_{p,Rd}$, from Table 3-4 of EN 1993-1-8.

(6) The design of steel load-distributing members should be in accordance with EN 1993-1-1.

(7) In the case of an inclined anchor, it should be demonstrated that the component of the anchor force acting in the direction of the longitudinal axis of the sheet pile can be safely transferred from the anchor to the walings or the flange of the sheet pile and into the ground, see EN 1997-1.

7.2.4 Serviceability limit state verification

(1)P For serviceability limit state verifications, the cross-section of the anchor shall be designed to prevent deformations due to yielding of the tie rod under the characteristic load combination.

(2) The principle (1)P may be deemed to be satisfied provided that

$$F_{t,ser} \leq \frac{f_y A_s}{\gamma_{Mt,ser}} \quad (7.3)$$

where:

- A_s is the tensile stress area of the threaded portion or the gross cross-sectional area of the shaft, whichever is smaller;

- $F_{t,ser}$ is the axial force of the anchor under characteristic loading;
 $\gamma_{M_t,ser}$ is the partial factor according to 7.1 (4).

7.2.5 Durability requirements

- (1) Reference should be made to EN 1537 for the durability requirements of anchors made from high strength steel as defined in 3.7 (1).
- (2) Reference should be made to 4.1 for anchors made from other steel grades.

NOTE: The occurrence of bending of the anchor rod at the connection with the sheet pile wall may have a detrimental effect on the durability of the retaining structure. Due consideration needs to be given to this, especially for retaining walls whose stability is reliant solely on anchors.

7.3 Walings and bracing

- (1) The structural properties of walings and bracing used in structural analysis should be in accordance with the design details.
- (2) For the verification of ultimate limit states, the effects of actions on the walings and bracing should be determined for all relevant design situations.

NOTE: If a strut fails there is unlikely to be any warning such as gradual movement, or any time to take remedial measures. Failure of an anchor may lead to progressive failure. As the consequences of these members failing can be very serious, a conservative approach to the design of such members and their connections may be appropriate.

- (3) The cross-sectional resistance of the members should be in accordance with EN 1993-1-1.

7.4 Connections

7.4.1 General

- (1) The resistance of connections should be verified according to EN 1993-1-8.

7.4.2 Bearing piles

- (1) Unless otherwise specified, the connection between the bearing pile and the pile cap may be taken into account in different (conservative) ways for the design of the steel pile and for the design of the pile cap.

NOTE: The degree of fixity at the connection between a pile and the pile cap or foundation will dictate the local shear forces and moments that have to be designed for.

- (2) The structural properties of connections (pinned or fixed connections) between the heads of the piles and the pile cap, which depend on their rigidity and design detailing, should be chosen in accordance with the selected method of load transfer, examples of which are provided in Figure 7-1 and Figure 7-2, see also EN 1994.

NOTE: Direct connection of a steel structure to a bearing pile is also possible as illustrated in Figure 7-3.

- (3) Durability aspects should be taken into account in the design of connections between pile and pile cap.
- (4) Joints between two pile elements should be designed in accordance with EN 1993-1-8.

NOTE: The National Annex may give information on the design procedure for pile couplers.

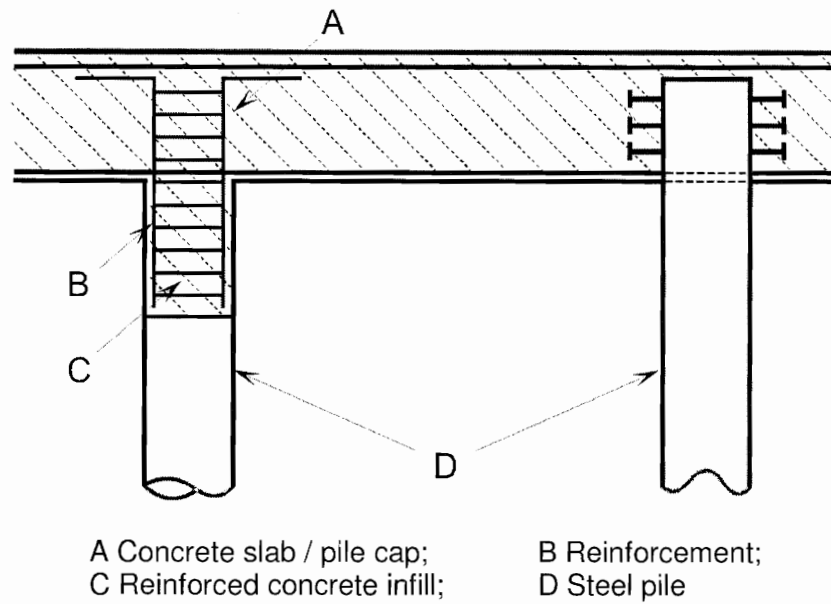
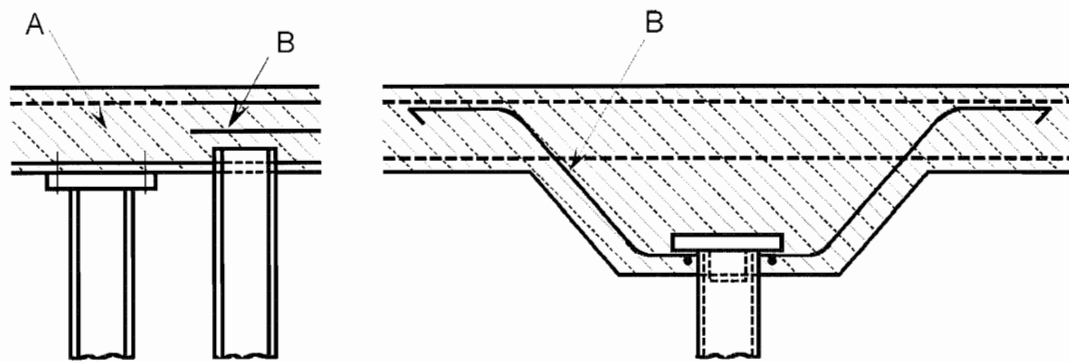
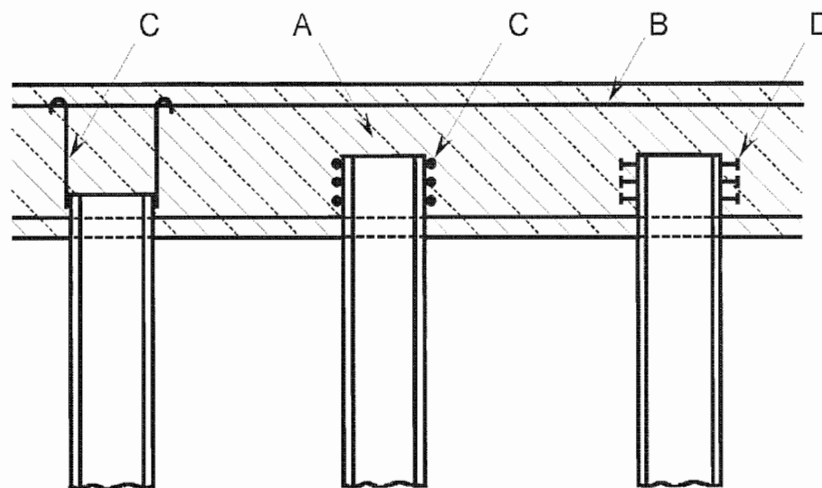

Figure 7-1: Tubular and box type piles, examples of connections with the pile cap



- A Pile cap;
- B reinforcement designed to take into account the method of load transfer to the concrete slab

a) compressive loading



- A Pile cap;
- B reinforcement designed to take into account the method of load transfer to the concrete slab
- C Rebar welded to piles
- D Shear studs or welded on angle

b) compressive and tensile loading

Figure 7-2: Examples of bearing pile connections with a concrete pile cap

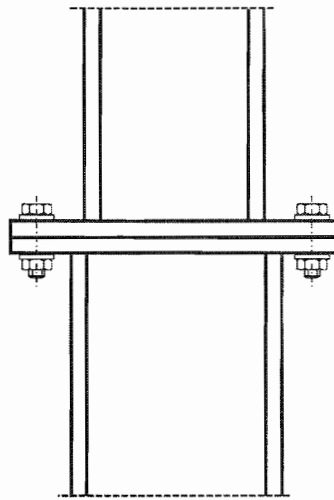

Figure 7-3: Example of a bearing pile connection to a column of a steel structure above the foundation

7.4.3 Anchoring

(1)P The resistance of the sheet pile to the introduction of the anchor force into its flange via a washer plate with a waling behind the wall (see Figure 7-4), or without using a waling (see Figure 7-5a), shall be verified.

NOTE: A possible procedure for this verification is given in (3).

(2)P The resistance of the sheet pile to the introduction of the anchor force or strut force into the webs via a waling (see Figure 7-6) or via a washer plate (see Figure 7-5b) shall be verified.

NOTE: Possible procedures for these verifications are given in (4) and (5).

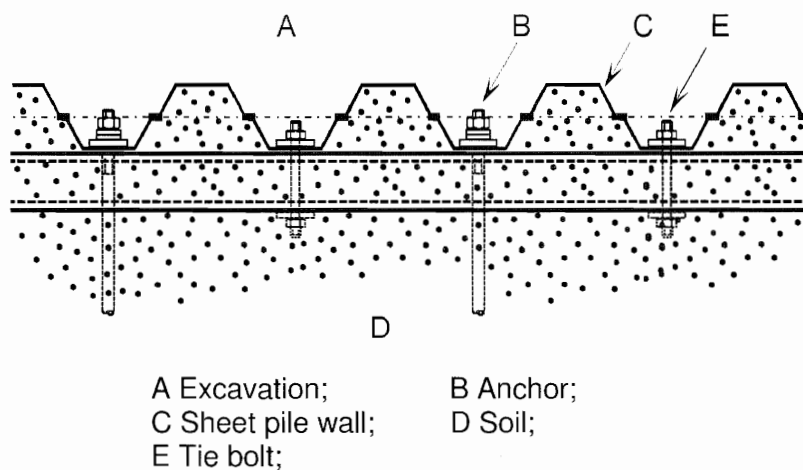
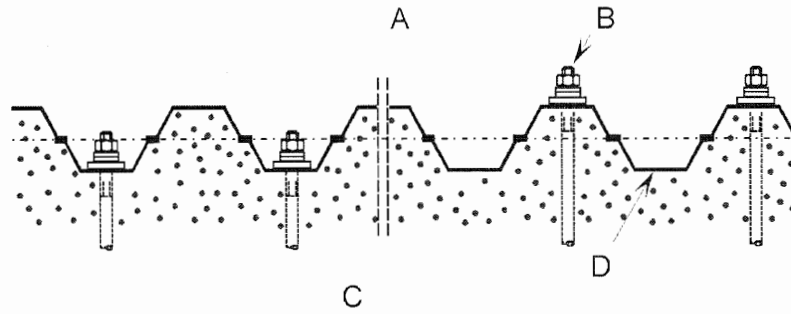

Figure 7-4: Example of anchoring with a waling behind the sheet pile wall



A Excavation; B Anchor;
C Soil; D Sheet pile wall

a) anchor located in an in-pan
of the sheet pile wall

b) anchor located on an out-pan
of the sheet pile wall

Figure 7-5: Examples of anchoring without a waling

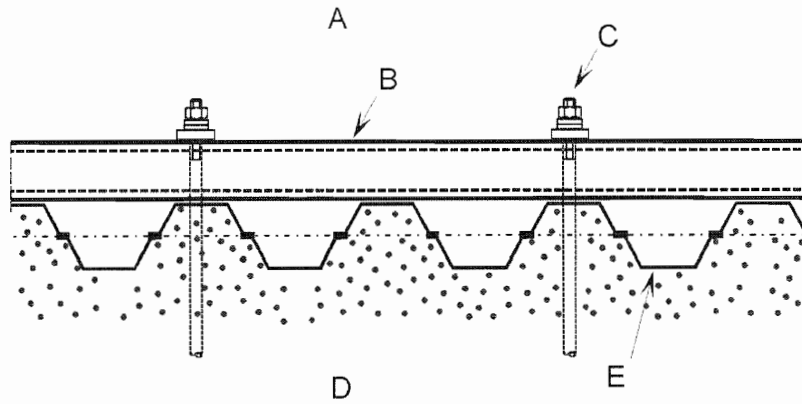

A Excavation; B Waling;
C Anchor; D Soil;
E Sheet pile wall

Figure 7-6: Example of a waling in front of the sheet pile wall

(3) The resistance of the sheet pile to that part of the anchor force to be introduced into the flange via a washer plate with a waling behind the wall (see Figure 7-4) or without using a waling (see Figure 7-5a) may be verified in accordance with the following:

a) Shear resistance of flange:

$$F_{Ed} \leq R_{Vf,Rd} \tag{7.4}$$

where:

F_{Ed} is the design value of the local transverse force applied through the flange;

$R_{Vf,Rd}$ is the design value of the shear resistance of the flange under the washer plate, given as

$$R_{Vf,Rd} = 2,0 (b_a + h_a) t_f \frac{f_y}{\sqrt{3} \gamma_{M0}} \tag{7.5}$$

with:

- b_a is the width of the washer plate;
- f_y is the yield strength of the sheet piling;
- h_a is the length of the washer plate, but $\leq 1,5 b_a$;
- t_f is the flange thickness;

b) tensile resistance of webs:

$$F_{Ed} \leq R_{tw,Rd} \quad (7.6)$$

where:

$R_{tw,Rd}$ is the design value of the tensile resistance of 2 webs, given as

$$R_{tw,Rd} = 2,0 h_a t_w f_y / \gamma_{M0} \quad (7.7)$$

with:

t_w is the web thickness;

c) width of washer plate:

$$b_a \geq 0,8 b \quad (7.8)$$

where:

b_a is the width of the washer plate;

b is the width of the flange, see figure in Table 5-1;

NOTE: A smaller value for b may be taken provided flange bending is checked.

d) thickness of washer plate:

the washer plate should be verified for bending and should have a minimum thickness of $2t_f$.

(4) The verification of the resistance of the sheet pile to that part of the anchor force or strut force to be introduced into the webs via a waling (see Figure 7-6) may be carried out as follows:

$F_{Ed} \leq 0,5 R_{c,Rd}$: no further verification necessary

$$F_{Ed} > 0,5 R_{c,Rd}: \frac{F_{Ed}}{R_{c,Rd}} + 0,5 \frac{M_{Ed}}{M_{c,Rd}} \leq 1,0 \quad (7.9)$$

where:

F_{Ed} is the design value of the local transverse force per web applied through the waling;

$R_{c,Rd}$ is the design resistance to the local transverse force. $R_{c,Rd}$ should be taken as the minimum of $R_{e,Rd}$ and $R_{p,Rd}$ for each web, given by:

$$R_{e,Rd} = \frac{\varepsilon}{4e} (s_S + 4,0 s_{ec}) \sin \alpha (t_w^2 + t_f^2) f_y / \gamma_{M0} \quad (7.10)$$

$$R_{p,Rd} = \chi R_{p0} / \gamma_{M0} \quad (7.11)$$

with:

$$\chi = 0,06 + \frac{0,47}{\lambda} \leq 1,0 \quad (7.12)$$

$$\lambda = \sqrt{\frac{R_{p0}}{R_{cr}}} \quad (7.13)$$

$$R_{cr} = 5,42 E \frac{t_w^3}{c} \sin \alpha \quad (7.14)$$

$$R_{p0} = \sqrt{2} \varepsilon f_y t_w \sin \alpha \left(s_S + t_f \sqrt{\frac{2b \sin \alpha}{t_w}} \right) \quad (7.15)$$

b is the width of the flange, see figure in Table 5-1;

c is the slant height of the web as shown in Figure 5-1;

e is the eccentricity of the force introduced into the web, given by

$$r_0 \tan \left(\frac{\alpha}{2} \right) - \frac{t_w}{2 \sin \alpha}, \text{ but not less than 5 mm;} \quad (7.16)$$

f_y is the yield strength of the sheet pile;

r_0 is the outside radius of the corner between flange and web;

$$s_{ec} = 2,0 \pi r_0 \left(\frac{\alpha}{180} \right) \text{ with } \alpha \text{ in degrees;} \quad (7.17)$$

- s_s is the length of stiff bearing, determined from 6.3 of EN 1993-1-5. If the waling consists of two parts, e.g. two channel-sections, s_s is the sum of both parts plus the minimum of the distance between the two parts or the length s_{ec} ;
- t_f is the flange thickness;
- t_w is the web thickness;
- α is the inclination of the web, see Figure 5-1;
- $\varepsilon = \sqrt{\frac{235}{f_y}}$ with f_y in N/mm²;
- M_{Ed} is the design value of the bending moment at the location of the anchor force or strut force;
- $M_{c,Rd}$ is the design bending resistance of the sheet pile from 5.2.2(2).

(5) If a washer plate is used for the introduction of the anchor force into the webs according to Figure 7-5b the expressions given in (4) may be applied, provided that the width of the washer plate is greater than the width of the flange to prevent an additional eccentricity e as given in (4).

8 Execution

8.1 General

- (1) The piling works should be carried out as defined for the project.
- (2) If there are differences between what is constructed on site and what has been defined for the project. The consequences should be investigated and modifications shall be introduced if necessary.
- (3) The execution requirements should conform with EN 1997-1.
- (4) Any specific requirements should be given for each project.

8.2 Steel sheet piling

- (1)P Sheet piling shall be executed in accordance with EN 12063.
- (2) The tolerances for position and verticality of sheet piles should be as specified in Table 2 of EN 12063.
- (3) In order for the piling to develop its nominal resistance and stiffness properties, the wall alignment should be in accordance with 8.5 of EN 12063.

8.3 Bearing piles

- (1)P The installation of bearing piles shall conform with 4 of EN 1997-1.
- (2)P The installation of bearing piles shall also be in accordance with EN 12699 and EN 14199.
- (3) The tolerances for position and verticality of bearing piles should be as specified in EN 12699 and EN 14199.

8.4 Anchorages

- (1) The execution of anchorages should be in accordance with EN 1997-1 and EN 1537 if applicable.

8.5 Walings, bracings and connections

- (1)P For the execution of structural components reference shall be made to EN 1090-2.

A [normative] - Thin walled steel sheet piling

A.1 General

A.1.1 Scope

- (1) This annex should be used for the determination of the resistance and stiffness of steel sheet piling and for some special aspects of cold-formed steel sheet piling with class 4 cross-sections. For the determination of actions and effects of actions, reference should be made to section 2.
- (2) Reference should be made to 5.2 for the classification of cross-sections.
- (3) Although the design methods in this annex are presented in terms of cold-formed sheet piling, they may also be applied to class 4 hot rolled profiles.
- (4) Design assisted by calculation included in this document, assumes that the cross-sections are limited to those made up of elements without intermediate stiffeners. This restriction need not be applied to the design assisted by testing, see A.7. For profiles made up of elements with intermediate stiffeners and designed by calculation reference should be made to EN 1993-1-3.
- (5) In the case of thin walled steel sheet piling, design by calculation may not always lead to economic solutions and it is often useful to use tests for the determination of resistance.

NOTE: Guidance for testing are given in Annex B.

- (6) Restrictions regarding geometrical properties or materials only apply to design by calculation.



A.1.2 Form of cold formed steel sheet piles

- (1) Cold formed steel sheet piles are products made from hot rolled flat products according to EN 10249. They consist of straight and rounded walls. Over their entire length, within the permitted tolerances, they have a constant cross-section and a thickness not less than 2 mm.
- (2) These sheet piles are obtained solely by cold forming (rolling or pressing).
- (3) The edges of the cross-section of a sheet pile may consist of interlocks.
- (4) Some examples of cold formed piling sections covered in this annex are given in Table A-1.

A.1.3 Terminology

- (1) The terminology for cross-section dimensions given in 1.5.3 of EN 1993-1-3 applies.
- (2) For cold formed steel sheet piles the axis convention given in 1.9 applies.

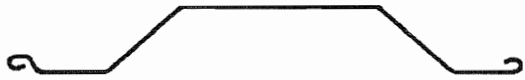
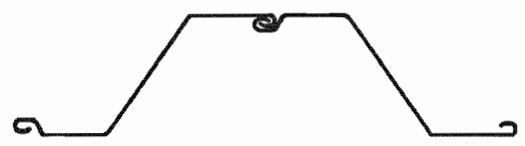
Table A-1: Examples of cold formed piling sections

	Example of cross-section
Ω - profile	
Z - profile	
Trench sheet profile	

A.2 Basis of design

A.2.1 Ultimate limit states

(1) The general provisions given in 2.2 and 5.1 should also be applied to cold formed profiles, except where different provisions are given in this annex.

A.2.2 Serviceability limit states

(1) The general provisions given in 2.3, 6.1 and 6.2 should also be applied to cold formed profiles, except where different provisions are given in this annex.

(2) Reference should be made to section 7 of EN 1993-1-3 for serviceability limit state verifications.

A.3 Properties of materials and cross-sections

A.3.1 Material properties

(1) For the properties of the materials covered in this annex reference should be made to section 3.

(2) The provisions given in this annex apply to class 4 steel sheet piles according to EN 10248 and EN 10249.

(3) These design methods may also be applied to other structural steels with similar strength and toughness properties, provided that all of the following conditions are satisfied:

- the steel satisfies the requirements for chemical analysis, mechanical tests and other control procedures to the extent and in the manner prescribed in EN 10248 or EN 10249;
- a minimum ductility is required that should be expressed in terms of limits of
 - f_u / f_y
 - the elongation at failure on a gauge length of $5,65 \sqrt{A_0}$ (where A_0 is the original cross-section area)
 - the ultimate strain ϵ_u , where ϵ_u corresponds to the ultimate strength f_u .

NOTE: These limiting values may be given in the National Annex. The following values are recommended:

- $f_u / f_y \geq 1,1$;
- elongation at failure $\geq 15 \%$;
- $\epsilon_u \geq 15 \epsilon_s$;
- where ϵ_s corresponds to the yield strength f_y ;
- the steel is supplied either:
 - according to another recognized standard for structural steel sheet, or
 - with mechanical properties and chemical composition at least equivalent to one of the steel grades that are listed in Table 3-1 or Table 3-2 respectively.

(4) The nominal values of the basic yield strength f_{yb} given in Table 3-1 and Table 3-2 should be adopted as characteristic values in design calculations. For other steels the characteristic values should be based on the results of tensile tests carried out in accordance with EN 10002-1.

(5) It may be assumed that the properties of steel in compression are the same as those in tension.

(6) For the steels covered by this annex, the other material properties to be used in design should be taken as follows:

- modulus of elasticity: $E = 210\,000 \text{ N/mm}^2$;
- shear modulus: $G = E / [2(1 + \nu)] \text{ N/mm}^2$;
- Poisson's ratio: $\nu = 0,3$;
- coefficient of linear thermal elongation: $\alpha = 12 \times 10^{-6} \text{ 1/K}$;
- unit mass: $\rho = 7850 \text{ kg/m}^3$.

(7) The effect of an increased yield strength due to cold forming may be taken into account on the basis of tests in accordance with A.7.

(8) Where the yield strength is specified using the symbol f_y either in this annex or in EN 1993-1-3, either the basic yield strength f_{yb} from Table 3-2 or the yield strength from Table 3-1 should be used.

NOTE: This differs from the convention used in EN 1993-1-3.

(9) The provisions for design by calculation given in this annex may be used only for steel within the range of nominal thickness t as follows:

$$2,0 \text{ mm} \leq t \leq 15,0 \text{ mm.}$$

(10) For thicker or thinner class 4 steel sheet pile cross-sections, the load bearing capacity should be determined by design assisted by testing in accordance with A.7.

A.3.2 Section properties

(1) Section properties should be calculated, taking due account of the sensitivity of the properties of the overall cross-section to any approximations used, see 5.1 of EN 1993-1-3, and their influence on the predicted resistance of the member.

(2) The effects of local buckling should be taken into account by using effective cross-sections as specified in A.4.

(3) The properties of the gross cross-section should be determined using the specified nominal dimensions. In calculating gross cross-sectional properties, small holes need not be deducted but allowance should be made for large openings.

(4) The net area of a pile cross-section, or an element of a cross-section, should be taken as its gross area minus appropriate deductions for all holes and openings.

(5) The influence of rounded corners on the profile properties should be taken into account according to 5.1.4 of EN 1993-1-3.

NOTE: An example of an idealized sheet pile cross-section with sharp corners is given in Figure A-1.

(6) For design by calculation, the width-to-thickness ratios should not exceed the values given in Table A-2.

(7) The use of width-to-thickness ratios exceeding these values is not precluded, but the resistance of the pile at ultimate limit states and its behaviour at serviceability limit states should be verified by testing in accordance with A.7.

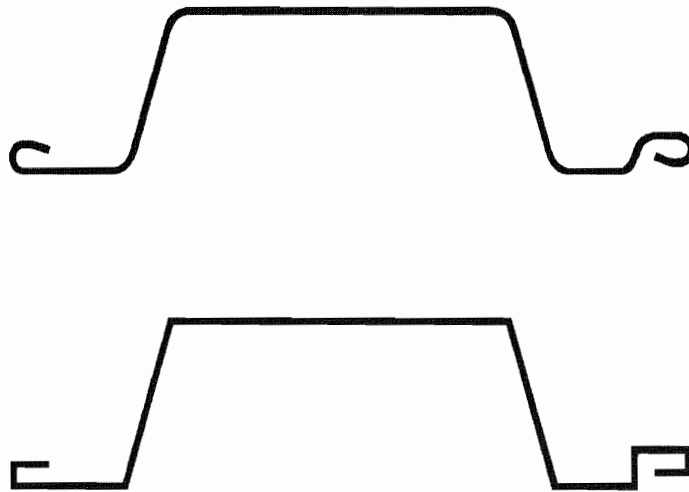
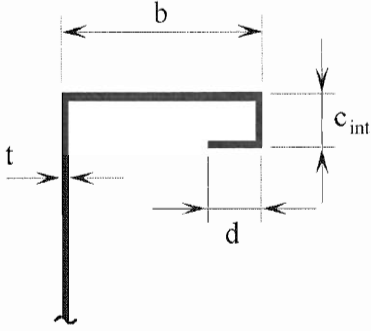
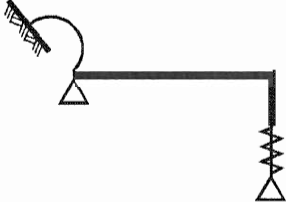
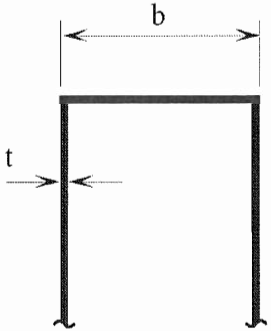

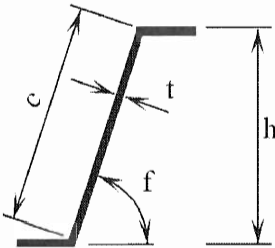
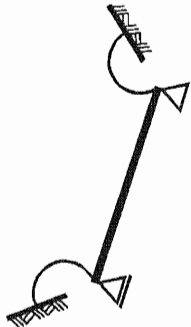

Figure A-1: Example of an idealized cross-section

Table A-2: Maximum width-to-thickness ratios; modelling of statical behaviour

Part of Cross section	Modelling of statical behaviour
	 <div style="text-align: center; border: 1px solid black; padding: 5px; width: fit-content; margin: 10px auto;">$b/t \leq 90$</div>
	 <div style="text-align: center; border: 1px solid black; padding: 5px; width: fit-content; margin: 10px auto;">$b/t \leq 200$</div>
	 <div style="text-align: center; border: 1px solid black; padding: 5px; width: fit-content; margin: 10px auto;">$45^\circ \leq \phi \leq 90^\circ$ $c/t \leq 200$</div>

A.4 Local buckling

- (1) The effects of local buckling should be taken into account in determining the resistance and stiffness of class 4 steel sheet pile cross-sections according to 5.5 of EN 1993-1-3, except where different provisions are given in this annex.
- (2) Unstiffened plane elements of sheet pile cross-sections are covered in 5.5.2 of EN 1993-1-3.
- (3) Plane elements with interlocks acting as edge stiffeners should be taken into account according to 5.5.3.2 of EN 1993-1-3.

NOTE: Figure A-2 gives an example of the idealization of the geometry of the interlock acting as an edge stiffener.

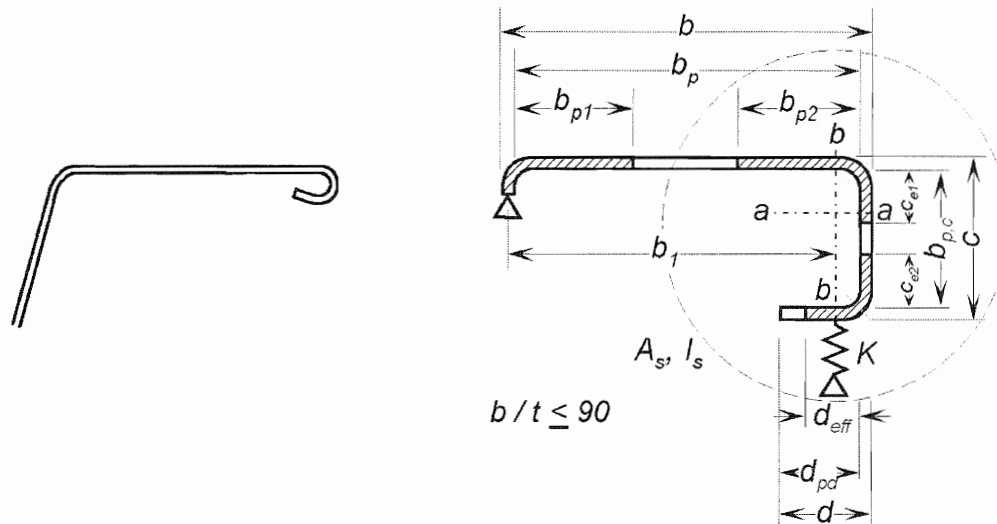

Figure A-2: Interlock to be treated as an edge stiffener

- (4) For plane compression elements with interlocks acting as edge stiffeners, the design should be based on the principle given in 5.5.3.1 (1) of EN 1993-1-3.
- (5) The spring stiffness of the interlock acting as an edge stiffener should be determined according to expression (5.9) of EN 1993-1-3.
- (6) Expression (5.10) of EN 1993-1-3 may be applied to sheet piling as follows for the Z-profile as shown in Figure A-3 and Figure A-4, by using the plate bending stiffness $(E t^3) / 12 / (1 - \nu^2)$. The stiffness of the rotational spring representing the web, see Figure A-4, may be determined from:

$$EI_w \theta = \frac{1}{2} \times 1 \times 1 \times s_w \quad (\text{A.1})$$

$$C_\theta = \frac{1}{\theta} = \frac{2EI_w}{c} \quad (\text{A.2})$$

$$I_w = \frac{t^3}{12(1-\nu^2)} \quad (\text{A.3})$$

The actual bending moment acting in the rotational spring due to the unit load is $u \times b_p$ and the corresponding rotation is given by:

$$\theta = \frac{u b_p}{C_\theta} = \frac{u b_p c}{2EI_w} \quad (\text{A.4})$$

So expression (5.10) of EN 1993-1-3 becomes:

$$\delta = \frac{2u b_p^2 (1-\nu^2)}{E t^3} (3c + 2b_p) \quad (\text{A.5})$$

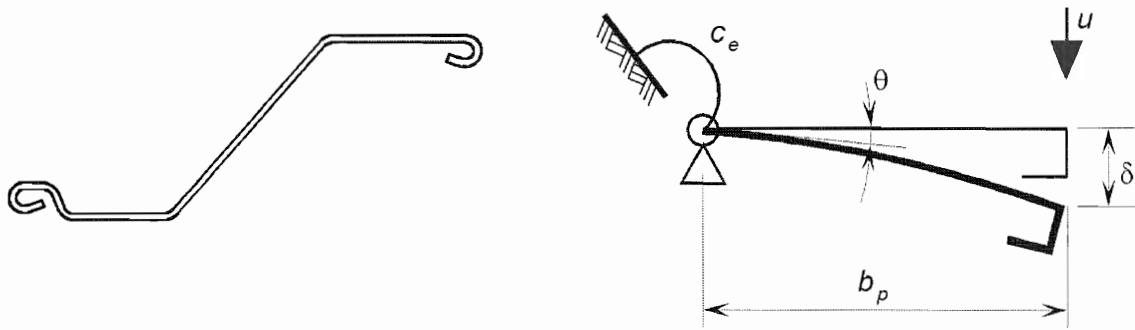

Figure A-3: Determination of spring stiffness of the flange

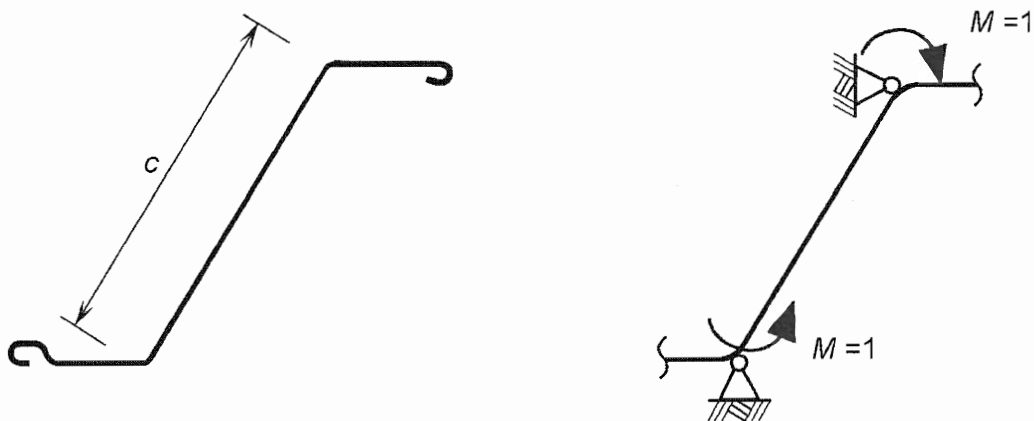

Figure A-4: Determination of the spring stiffness of the web

A.5 Resistance of cross-sections

A.5.1 General

- (1)P The design values of the internal forces and moments at each cross-section shall not exceed the design values of the corresponding resistances.
- (2) The design resistance of a cross-section should be determined either by calculation, using the methods given in this section, or by design assisted by testing, in accordance with A.7.
- (3) The provisions of A.5 should not be applied except for monoaxial bending with $M_z = 0$.
- (4) It may be assumed that one of the principal axes of the sheet piling is parallel to the system axis of the retaining wall.
- (5) For design by calculation, the resistance of the cross-section should be verified for:
 - bending moment, taking into account the effects of local transverse bending;
 - local transverse forces;

- combined bending moment and shear force;
- combined bending moment and axial force;
- combined bending moment and local transverse forces.

(6) Design assisted by testing may be used instead of design by calculation for any of these resistances.

NOTE: Design assisted by testing is particularly likely to be beneficial for cross-sections with relatively high b_p/t ratios, for instance in relation to inelastic behaviour or web crippling.

(7) For design by calculation, the effects of local buckling should be taken into account by using effective cross-sectional properties determined as specified in A.4.

(8) The provisions given in this section do not account for possible global instability of the sheet piles, so for sheet piling where instability due to compression forces may occur, reference should be made to section 6.2 of EN 1993-1-3.

(9) The criterion given in 5.2.3(1) should be applied. Higher axial forces leading to overall instability should be avoided when using class 4 cross-sections.

(10) Walings in front of or behind the sheet pile wall should be used to introduce forces from anchors or struts (see Figure A-5a), thereby allowing for redistribution of the forces. If a washer plate is used to introduce the force from a tie rod directly into the sheet pile as shown in Figure A-5b, tests in accordance with section 2.6 should be carried out if the thickness of the sheet pile profile is ≤ 6 mm.

(11) When using iterative calculation procedures, several iterations should be carried out if necessary to avoid a lack of accuracy.

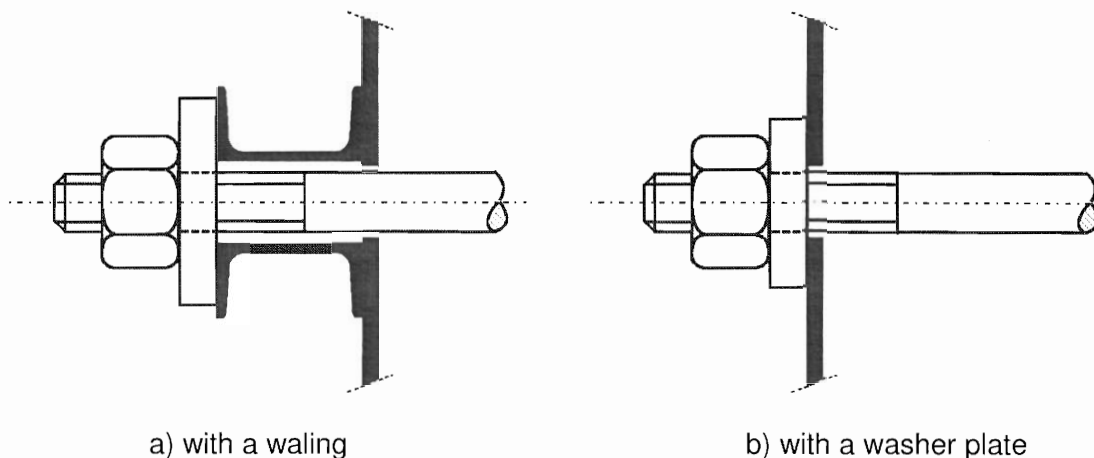

Figure A-5: Introduction of anchor forces

A.5.2 Bending moment

- (1) The moment resistance of the class 4 sheet pile cross-section should be determined according to 6.1.4 of EN 1993-1-3, except where different provisions are given in this annex.
- (2) The effects of shear lag may be neglected in steel sheet piling.
- (3) No plastic redistribution of bending moments should be made in retaining walls consisting of class 4 cross-sections.
- (4) If the moment resistance of the profile is different for positive and negative bending moments, this should be taken into account in the design.

A.5.3 Shear force

- (1) The shear resistance of the web should be determined according to 6.1.5 of EN 1993-1-3, except where different provisions are given in this annex.
- (2) The shear buckling strength f_{bv} should be determined using Table 6-1 of EN 1993-1-3 for webs without stiffening at the support.

A.5.4 Local transverse forces

A.5.4.1 General

- (1) If the waling is located in front of the wall on the excavation side as shown in Figure 7-6, the verification should be carried out according to A.5.4.2.
- (2) If the waling is located behind the wall as shown in Figure 7-4, the verification should be carried out according to A.5.4.3.

A.5.4.2 Webs subject to transverse compressive forces

- (1) To avoid crushing, crippling or buckling in a web subject to a support reaction via a waling, the applied transverse force F_{Ed} should satisfy:

$$F_{Ed} \leq R_{w,Rd}$$

where:

$R_{w,Rd}$ is the local transverse resistance of the web.

(2) For an unstiffened web, the local transverse resistance $R_{w,Rd}$ should be obtained from 6.1.7.3 of EN 1993-1-3 except where different provisions are given in this annex.

NOTE: Z-profiles are covered by this paragraph, considering a double pile made up of two Z-profiles.

(3) For a waling acting as support:

- the value of the effective bearing length l_a to be used in expression (6.18) of EN 1993-1-3 should be determined according to 6.1.7.3 (4) of EN 1993-1-3;
- the value of the coefficient α to be used in expression (6.18) of EN 1993-1-3 should be obtained from the following:

for category 1: $\alpha = 0,075$

for category 2: $\alpha = 0,15$.

NOTE: Category 1 applies if the distance between the waling and the edge of the pile is $\leq 1,5 h_w$, where h_w is the depth of the profile, otherwise category 2 applies, see Figure 6-9 of EN 1993-1-3.

A.5.4.3 Webs subject to transverse tensile forces

(1) For webs subject to transverse tensile forces, checks should be carried out in accordance with 7.4.3 (3).

A.5.5 Combined shear force and bending moment

(1) For combined shear force and bending moment, the verification should be carried out using expression (6.27) of EN 1993-1-3.

A.5.6 Combined bending moment and local transverse forces

(1) For combined bending moment and local transverse forces, the verification should be carried out according to 6.1.11 of EN 1993-1-3.

A.5.7 Combined bending moment and axial force

(1) The combination of bending moment with axial tension should be verified according to 6.1.8 of EN 1993-1-3, without taking bending about the z-z axis into account.

(2) The verification for combined bending moment and axial compression should be carried out according to 6.1.9 of EN 1993-1-3 without taking bending about the z-z axis into account.

A.5.8 Local transverse bending

(1) In the case of a differential water pressure exceeding 1 m head, the effects of water pressure on transverse local plate bending should be taken into account when determining the overall bending resistance.

(2) As a simplification, this verification may be carried out using the following procedure:

- the cross-sectional verification need only be carried out at the locations of the maximum moments where the differential water pressure is more than 1 m head;
- the effect of differential water pressure should be taken into account by using a reduced plate thickness $t_{red} = \rho_p t$ with ρ_p according to Table A-3;
- for the determination of ρ_p according to Table A-3 the differential water pressure acting at the relevant locations of the maximum moments should be taken into account.

Table A-3: Reduction factors ρ_p for plate thickness due to differential water pressure

w	$(b/t_{min}) \varepsilon = 40,0$	$(b/t_{min}) \varepsilon = 60,0$	$(b/t_{min}) \varepsilon = 80,0$	$(b/t_{min}) \varepsilon = 100,0$
1,0	0,99	0,98	0,96	0,94
2,5	0,98	0,94	0,88	0,78
5,0	0,95	0,86	0,67	0,00
7,5	0,92	0,75	0,00	0,00
10,0	0,88	0,58	0,00	0,00

Key:

b is the width of the flange, but b should not be taken as less than $c/\sqrt{2}$, where c is the slant height of the web;

t_{min} is the minimum thickness of flange or web;

w is the head of differential water pressure in m;

$$\varepsilon = \sqrt{\frac{235}{f_y}}, \text{ with } f_y \text{ in N/mm}^2$$

Note: These values apply to Z-piles and are conservative for Ω - and U-piles. An increase of ρ_p is possible (for instance if interlocks are welded), but an additional investigation is then necessary.

A.6 Design by calculation

- (1) The following procedure may be adopted for the design of a retaining wall made up of class 4 sheet piles.
- (2) The effects of actions in the piles at ultimate limit states may be determined using an elastic beam model and an appropriate model for the soil in accordance with EN 1997-1.
- (3) If required, the structural input data for the beam model should be chosen as a best estimate.
- (4) For axial compression it should be verified whether buckling may be neglected.
- (5) For design by calculation to be applicable, it should be verified that the corresponding criteria given in this annex are fulfilled by the steel sheet piles that are expected to be used.

(6) Based on the resistances of the cross-sections provided by the manufacturer of the steel sheet piles, the chosen pile cross-section should be verified according to A.5, making due allowance for corrosion effects, if necessary.

NOTE: The cross-section resistance data that may be provided by the manufacturer are: $M_{c,Rk}$, N_{Rk} , $V_{b,Rk}$, $R_{w,Rk}$, taking into account the steel grade and the reduced thickness due to corrosion.

(7) If required, the effective stiffness of the cross-section at ultimate limit states should be used with the beam model in an iterative procedure.

NOTE: The stiffness data for the cross-section at ultimate limit states may be provided by the manufacturer in section property tables.

(8) If a verification at serviceability limit states is required, an elastic beam model combined with an appropriate model for the soil in accordance with 1997-1 may be used.

(9) Reference should be made to section 7.1 of EN 1993-1-3 for the determination of the cross-section stiffness data to be used for serviceability states verifications.

A.7 Design assisted by testing

A.7.1 Basis

(1) The following procedure should be used to apply the principles for design assisted by testing given in section 5 of EN 1990, to the specific requirements of cold formed steel sheet piling.

(2) Although the following provisions have been developed for cold formed profiles, they may also be applied to hot rolled steel sheet piles.

(3) Testing may be undertaken under any of the following circumstances:

- a) if the properties of the steel are unknown;
- b) if there is a need to take account of the actual properties of the cold formed profile;
- c) if adequate analytical procedures are not available for designing a sheet pile profile by calculation alone;
- d) if realistic data for design cannot otherwise be obtained;
- e) if the performance of an existing structure needs to be checked;
- f) if it is desirable to build a number of similar structures or components on the basis of a prototype;
- g) if confirmation of consistency of production is required;
- h) if it is necessary to prove the validity and adequacy of an analytical procedure;
- i) if it is desirable to produce resistance tables based on tests, or on a combination of testing and analysis;
- j) if it is desirable to take into account practical factors that may alter the performance of a structure, but are not addressed by the relevant analysis method in design by calculation.

- (4) Testing as a basis for tables of load carrying capacity should be carried out in accordance with A.7.3.

NOTE: Information is given in Annex B on procedures for thin walled steel sheet piles.

- (5) Tensile testing of steel should be carried out in accordance with EN 10002-1. Testing of other steel properties should be carried out in accordance with the relevant European Standards.

A.7.2 Conditions

- (1) The provisions given in A.3.1 of EN 1993-1-3 should be applied, except where different provisions are given in this annex.
- (2) During load application, up to attainment of the service load, the load may be removed and then reapplied. For this purpose the service load may be estimated as 30 % of the ultimate load. Above the service load, the loading should be held constant at each increment until any time-dependent deformations due to plastic behaviour have become negligible.

A.7.3 Cross-sectional data based on testing

- (1) The cross-sectional resistances and the effective stiffness of a cold formed steel sheet pile may be determined according to A.4.2 of EN1993-1-3.

B [informative] - Testing of thin walled steel sheet piles

B.1 General

- (1) Loading may be applied through air bags, or by cross beams arranged to simulate distributed loading. To prevent distortion of the profile at the points of load application or support, transverse ties and/or stiffeners (such as timber blocks or steel plates) may be applied.
- (2) For tests on Z-piles at least one double sheet pile should be used.
- (3) For Ω -piles at least one sheet pile should be used.
- (4) The accuracy of measurement should be consistent with the magnitude of the measurements and should be within $\pm 1\%$ of the value to be determined.
- (5) The cross-sectional measurements of the test specimen should cover the following geometrical properties:
 - overall dimensions (width, depth and length) to an accuracy of $\pm 1,0$ mm;
 - width of flat profile parts to an accuracy of $\pm 1,0$ mm;
 - radii of bends to an accuracy of $\pm 1,0$ mm;
 - inclination of flat walls (angle between two surfaces) to an accuracy of $\pm 2^\circ$;
 - the thickness of the material to an accuracy of $\pm 0,1$ mm.
- (6) It should be ensured that the load direction remains constant during the test.

B.2 Single span beam test

- (1) The test setup shown in Figure B-1 should be used to obtain the moment resistance (when the shear force is negligible) and the effective bending stiffness.
- (2) In this test at least two load points as shown in Figure B-1 should be used.
- (3) The span should be chosen in such a way that the test results represent the moment resistance of the sheet piling. The deflections should be measured in the middle of the span on both sides of the sheet (excluding the deformations of the supports).
- (4) The maximum load applied to the specimen coincident with or prior to failure should be recorded as representing the ultimate bending moment resistance. The bending stiffness should be obtained from the load deflection curve.

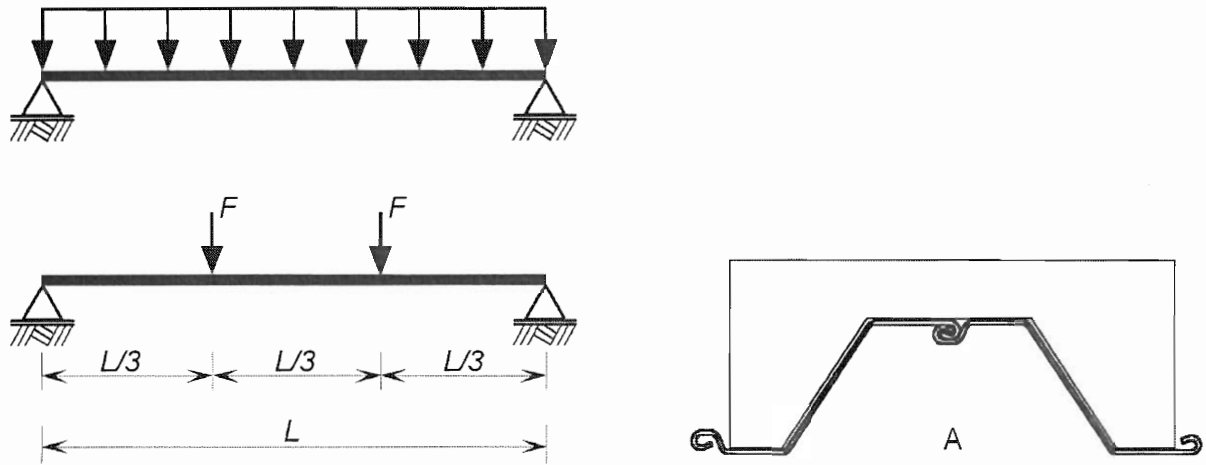

a) Loading

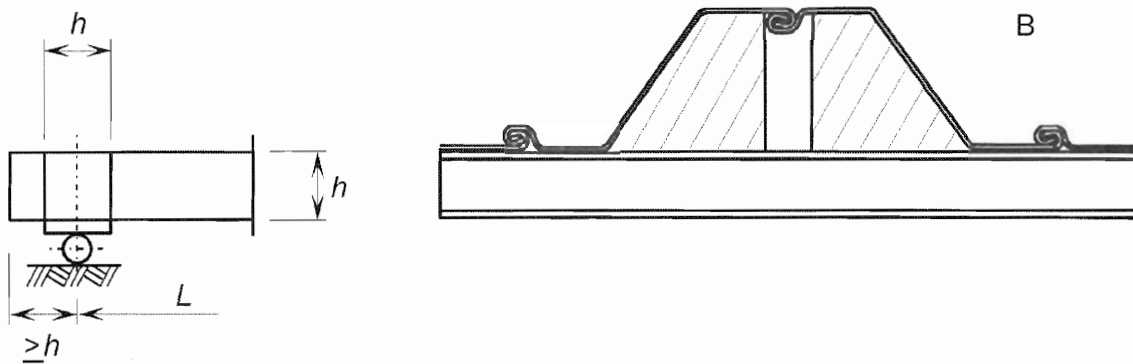

b) Preventing distortion of the section

A at the loading point
B at the support

NOTE: The direction of loading may also need to be reversed for unsymmetrical sections.

Figure B-1: Test set-up for moment resistance determination

B.3 Intermediate support test

- (1) The test setup shown in Figure B-2 may be used to obtain the resistance to combined bending moment and shear force at the intermediate support of sheet piling, as well as the interaction between moment and support reaction for a given support (waling) width.
- (2) In order to obtain a comprehensive record of the declining (unstable) part of the load deflection curve, the test should be continued for a suitable period after reaching the maximum load.
- (3) The test span L should be selected so that it represents the portion of the pile between the points of contraflexure each side of the support.
- (4) The width of the loading bar b_B should represent the waling width used in practice.

- (5) The deformations of the specimen should be measured on both sides of the specimen (excluding the deformations of the supports).
- (6) The maximum load applied to the specimen coincident with or prior to failure should be recorded as the ultimate crippling load. This represents the support bending moment and the support reaction for a given support width. To obtain information about the interaction between the moment and the support reaction, tests should be carried out with various spans.

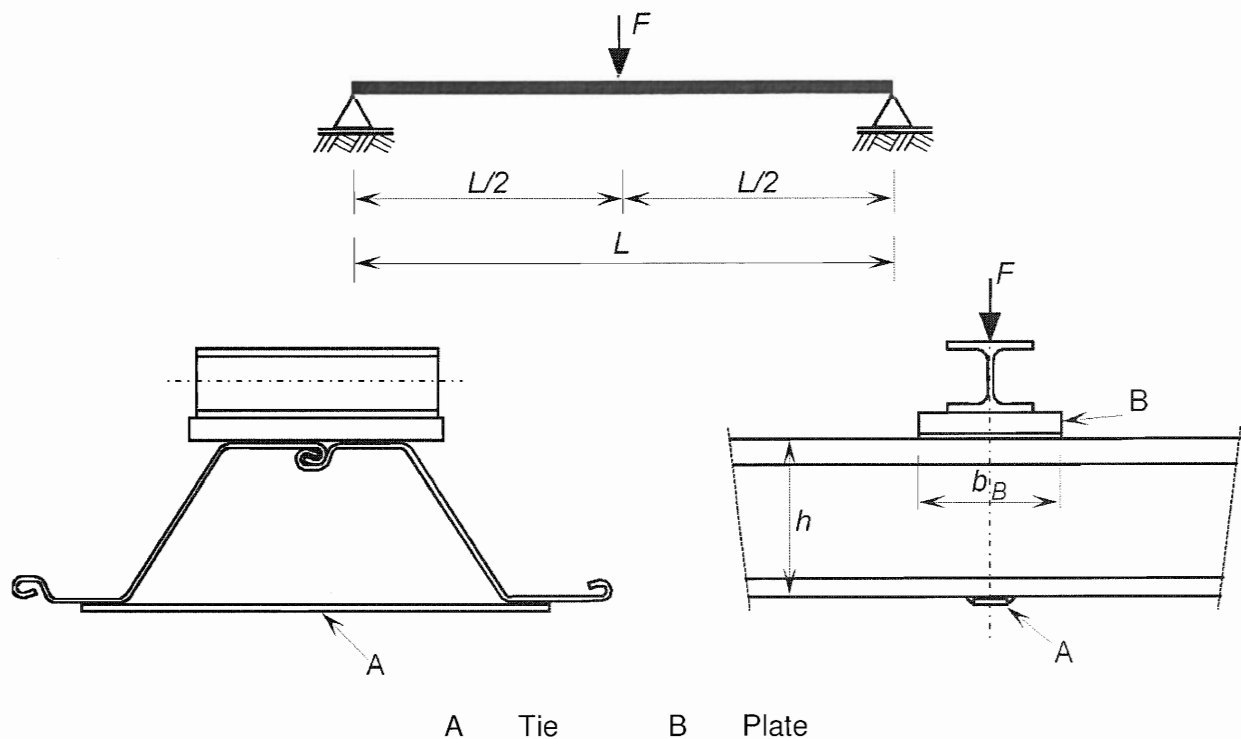

Figure B-2: Load introduction for the determination of bending resistance and shear resistance at intermediate support (waling)

B.4 Double span beam test

- (1) As an alternative to B.3 double span beam tests may be carried out to determine the ultimate resistance of cold formed sheet piling. The loading should preferably be applied uniformly distributed (e.g. air bag).
- (2) This loading may be replaced by any number of point loads that adequately reflect the behaviour under uniformly distributed loading (see Figure B-3).

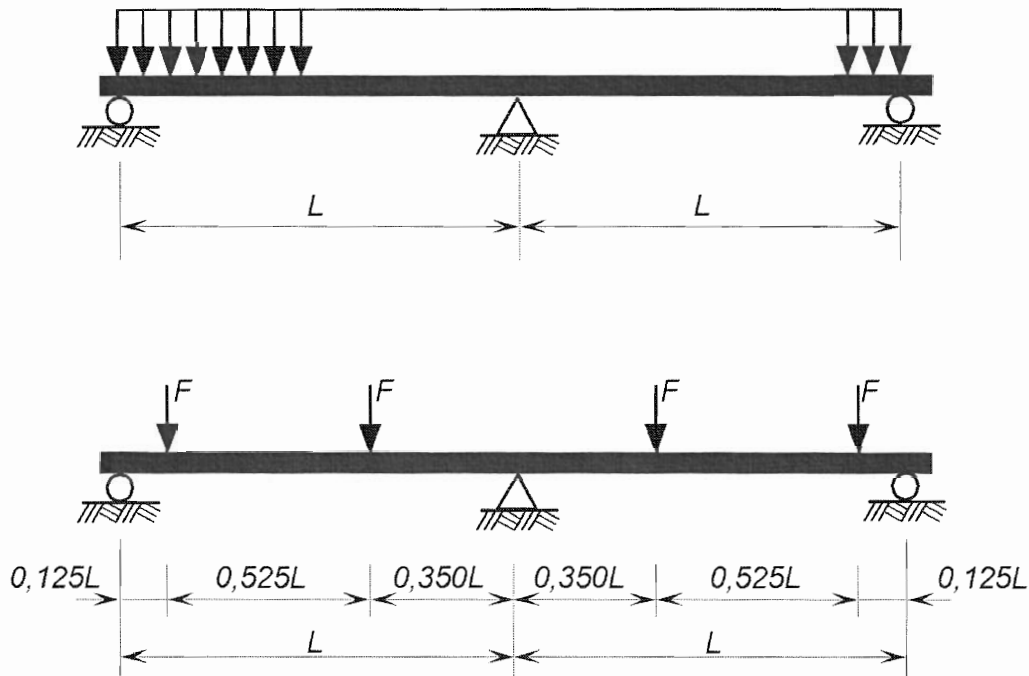

Figure B-3: Test set-up for double span tests

B.5 Evaluation of test results

B.5.1 General

(1) A specimen under test should be regarded as having failed if the applied test loads reach their maximum values, or if gross deformations exceeding agreed limits occur, see A.6.1 of EN 1993-1-3.

B.5.2 Adjustment of test results

(1) For the adjustment of test results reference should be made to A.6.2 of EN 1993-1-3.

B.5.3 Characteristic values

(1) The characteristic value R_k may be determined from test results according to A.6.3 of EN 1993-1-3.

B.5.4 Design values

(1) The design value of a resistance R_d should be derived from the corresponding characteristic value R_k determined by testing, using:

$$R_d = R_k / \gamma_M / \eta_{sys} \quad (\text{B.1})$$

where:

γ_M is the partial factor for resistance according to 5.1.1 (4);

η_{sys} is a factor for differences in behaviour under test and service conditions.

NOTE 1: The value to be ascribed to the symbol η_{sys} may be given in the National Annex. For the well defined standard testing procedures given in B.2, B.3 and B.4, $\eta_{sys} = 1,0$ is recommended.

NOTE 2: The value of χ_M can be determined using statistical methods for a family of at least four tests. Reference should be made to Annex D of EN 1990.

C [informative] - Guidance for the design of steel sheet piling

C.1 Design of sheet pile cross section at ultimate limit state

C.1.1 General

- (1) The design values of the effects of actions should not exceed the design resistance of the cross-section.
- (2) The design resistance should be determined taking into account a carefully chosen structural design model in accordance with 2.5.
- (3) If required the reduction of cross section properties due to a loss of thickness induced by corrosion should be taken into account in accordance with 4.
- (4) For U-piles possible lack of shear force transmission in the interlocks should be taken into account according to 5.2.2 (2).
- (5) If the sheet piling is subject to transverse bending due to differential water pressure, the effects of the water pressure should be taken into account using 5.2.4.
- (6) The resistance of the cross-section to the introduction of an anchor force into the flange of the sheet pile via a washer plate, or of an anchor or strut force into the webs of the sheet pile via a waling, should be determined according to 7.4.3.
- (7) If the cross-sectional properties chosen for the determination of internal forces and moments do not satisfy the criteria given in (1) to (4), a new profile (or another steel grade) should be chosen and the calculation procedure repeated.
- (8) Plastic resistance may be used for class 1 and class 2 cross-sections.
- (9) If no moment redistribution, and therefore no plastic rotation, is taken into account for class 1 or 2 profiles, determination of the effects of actions for the verification of the cross-section may be carried out using an elastic beam model.
- (10) If moment redistribution, and therefore plastic rotation, is taken into account in a design, the following design considerations should be fulfilled:
 - only class 1 or class 2 cross-sections should be used in combination with a rotation check as given below;
 - the verification of the cross-sections should be carried out using a beam model that allows for plastic rotation (e.g. plastic zone or plastic hinge beam model).

C.1.2 Verification of class 1 and class 2 cross-sections

- (1) The classification of a cross-section may be carried out by using b/t_f ratios according to one of the following procedures:
 - classification according to Table 5-1: b/t_f ratios determined for the full plastic moment resistance;
 - classification according to Table C-1 in which the b/t_f ratios are given for 85 % to 100 % of the full plastic moment resistance, in steps of 5 %.

(2) If classification with a reduced level of the full plastic moment resistance with a reduction factor $\rho_C = 0,85$ to $0,95$ is used to determine a class 1 or class 2 cross-section, then the design resistance of the cross-section should be determined with a reduced yield strength $f_{y,red} = \rho_C f_y$.

Table C-1: Classification of cross-sections in bending on a reduced $M_{pl,Rd}$ level

Type of pile	$M_{pl,Rd}$	100 %	95 %	90 %	85 %
	Reduction factor ρ_C	1,0	0,95	0,90	0,85
U-piles	Class 1 or 2	$\frac{b/t_f}{\epsilon} \leq 37$	$\frac{b/t_f}{\epsilon} \leq 40$	$\frac{b/t_f}{\epsilon} \leq 46$	$\frac{b/t_f}{\epsilon} \leq 49$
Z-piles	Class 1 or 2	$\frac{b/t_f}{\epsilon} \leq 45$	$\frac{b/t_f}{\epsilon} \leq 50$	$\frac{b/t_f}{\epsilon} \leq 60$	$\frac{b/t_f}{\epsilon} \leq 66$

(3) A plastic design with moment redistribution using class 1 or class 2 cross-sections may be carried out, provided that it can be shown that:

$$\phi_{Cd} \geq \phi_{Ed} \tag{C.1}$$

where:

ϕ_{Cd} is the design plastic rotation angle provided by the cross-section, see Figure C-1 and Figure C-2;

ϕ_{Ed} is the maximum design rotation angle demand for the actual design case.

(4) Plastic rotation angles ϕ_{Cd} are given in Figure C-1 for different $M_{pl,Rd}$ levels, dependent on $b/t_f/\epsilon$ ratios of the cross-section. These diagrams are based on results from bending tests with steel sheet piles, see Figure C-2.

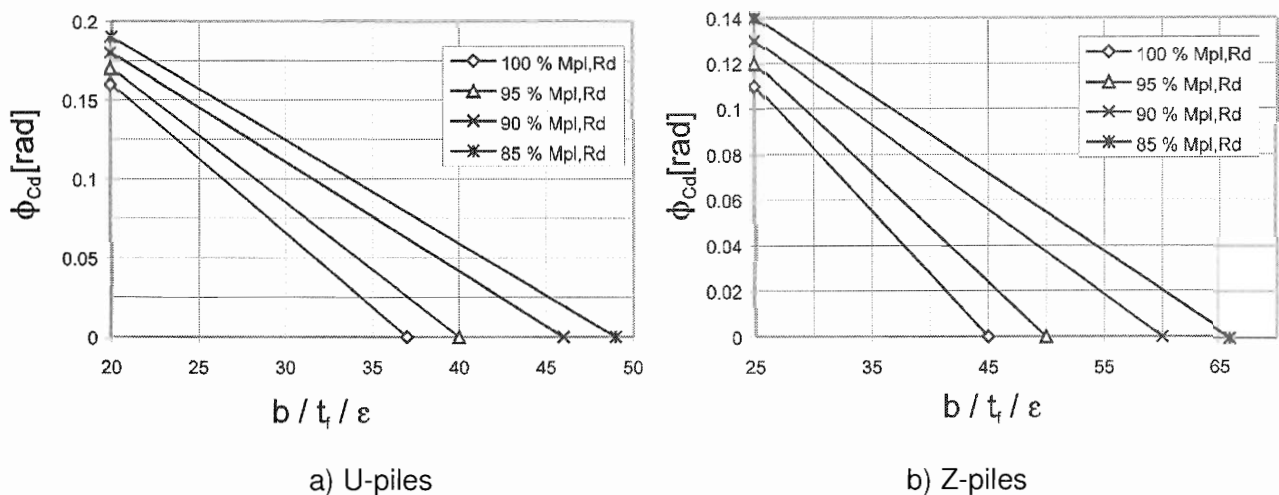

Figure C-1: Plastic rotation angle ϕ_{Cd} provided by the cross-section at different levels of $M_{pl,Rd}$

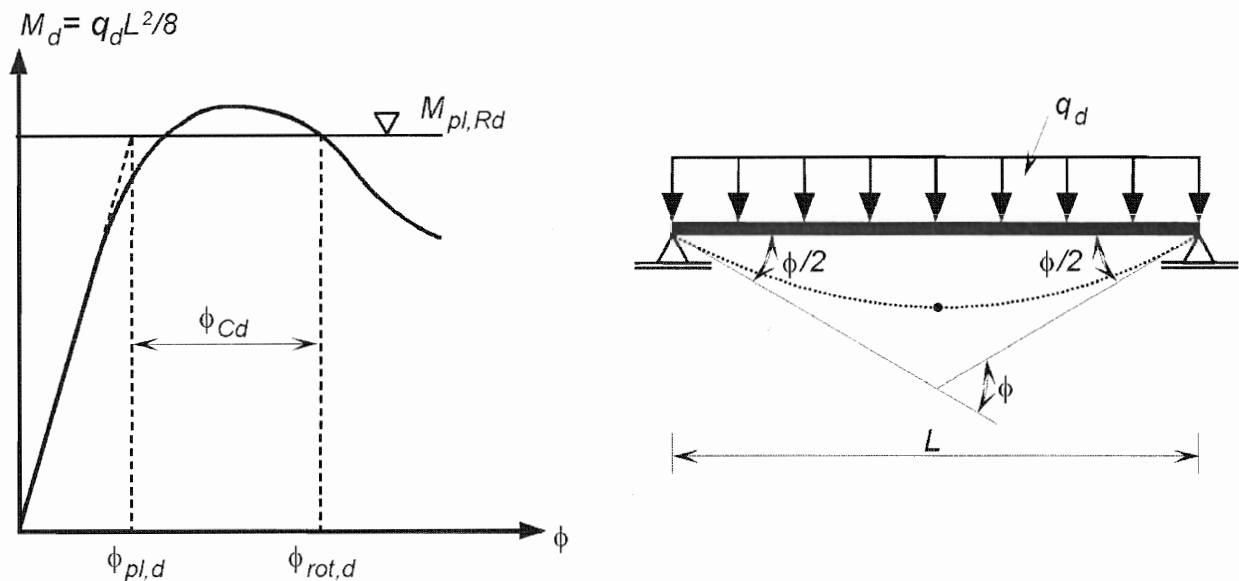

Figure C-2: Definition of the plastic rotation angle ϕ_{Cd}

(5) The design rotation angle ϕ_{Ed} for the actual design case may be determined using one of the following procedures:

a) for plastic hinge models:

ϕ_{Ed} is the maximum rotation angle in any plastic hinge;

b) alternatively for plastic hinge models and for plastic zone models:

$$\phi_{Ed} = \phi_{rot,Ed} - \phi_{pl,Ed} \quad (C.2)$$

where:

$\phi_{rot,Ed}$ is the design angle at ultimate limit state, measured at the points of zero moment (see Figure C-3);

$\phi_{pl,Ed}$ is the design elastic rotation angle, determined for the plastic moment resistance M_{pl} .

NOTE: As a simplified procedure $\phi_{pl,Ed}$ may be determined as follows:

$$\phi_{pl,Ed} = \frac{2 M_{pl,Rd} L}{3 \beta_D EI} \quad (C.3)$$

where:

L is the distance between the points of zero moment at ultimate limit state, see Figure C-3;

EI is the elastic bending stiffness of the sheet pile;

β_D is a factor defined in 6.4(3).

- c) for plastic hinge or plastic zone models, using rotations determined from calculated displacements of the wall as shown in Figure C-4:

$$\phi_{Ed} = \phi_{rot,Ed} - \phi_{pl,Ed}, \quad (C.4)$$

with:

$$\phi_{rot,Ed} = \frac{w_2 - w_1}{L_1} + \frac{w_2 - w_3}{L_2} \quad (C.5)$$

$$\phi_{pl,Ed} = \frac{5 M_{pl,Rd} L}{12 \beta_D EI} \quad (C.6)$$

NOTE: If the calculation program used for the design allows unloading of the sheet pile after the calculation process in order to obtain the plastic deformation, ϕ_{Ed} can be determined in this way and determination of the remaining plastic deformation is then straight forward.

C.2 Serviceability limit state

- (1) In the case of U-piles, possible lack of shear force transmission in the interlocks should be taken into account according to 6.4.

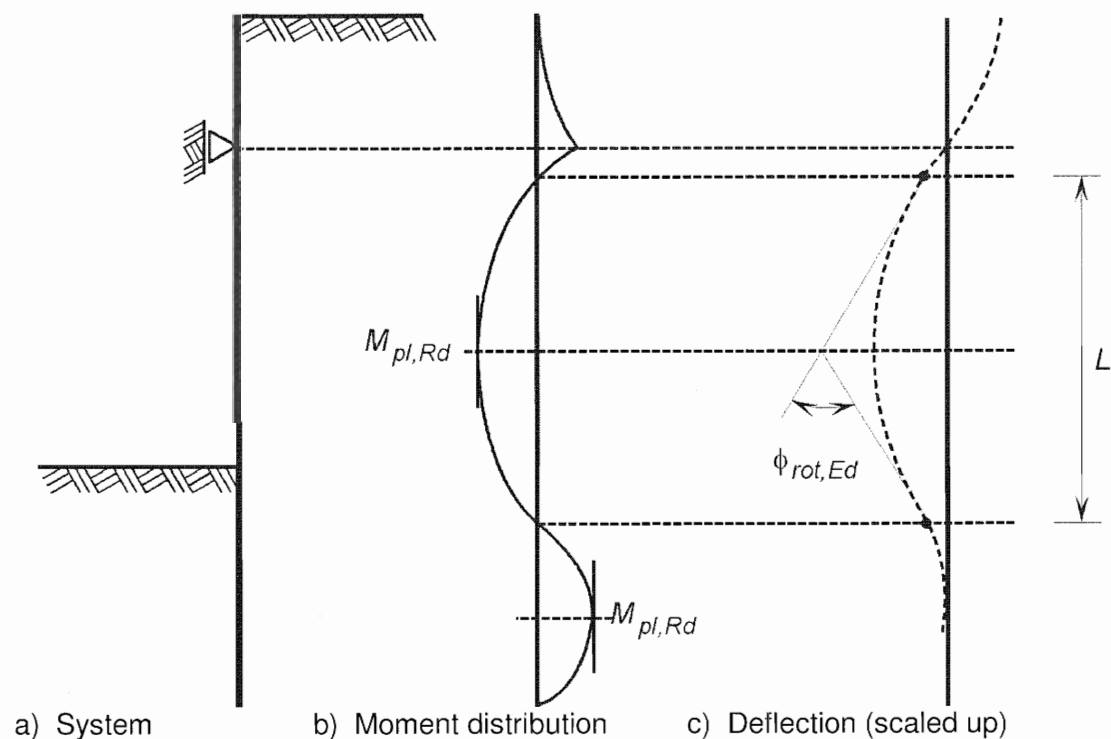

Figure C-3: Example of the determination of the total rotation angle $\phi_{rot,Ed}$

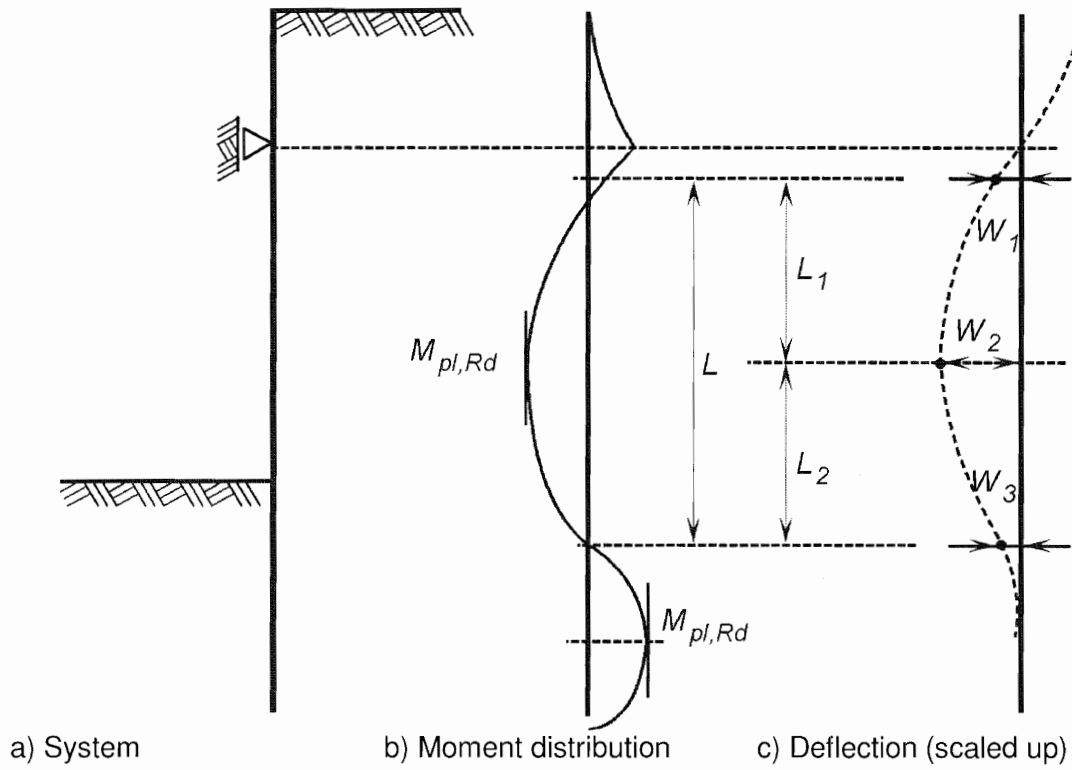

Figure C-4: Notation for the determination of the total rotation angle $\phi_{rot,Ed}$ from displacements

D [informative] - Primary elements of combined walls

D.1 I-sections used as primary elements

D.1.1 General

(1) I-sections used as primary elements in combined walls, see Figure 1-5, which appear to be class 1, class 2 or class 3 sections according to Table 5-2 of EN1993-1-1, may be verified according to the procedure given in D.1.2.

NOTE: Class 4 cross-sections should be verified according to EN1993-1-3 and EN1993-1-7.

(2) If criterion (5.1) in EN1993-1-1 is not fulfilled, the global internal forces and moments should be determined using a beam model with second order theory. Reference should be made to 5.2.3 for the determination of the buckling length.

(3) If required, the local plate bending stresses due to the design forces introduced by the secondary elements via connections should be taken into account in accordance with 5.5.4, see Figure D-1.

D.1.2 Verification method

(1) If no more advanced method is used, the following simplified procedure allows for the verification of I-sections taking into account the interaction between overall bending, normal forces and local plate bending in the flanges due to design forces from the secondary elements.

NOTE: Using a more advanced calculation method that takes into account both material and geometrical non-linearities may lead to a more economical design. This approach is also recommended to deal with higher water pressures exceeding 10m head.

(2) Up to a water pressure (or equivalent earth pressure in very soft soils) of $h = 10\text{m}$ head the interaction between overall action effects and local plate bending may be taken into account as follows:

- The cross-sectional verification of the primary elements should be carried out according to 6.2.9.2 and 6.2.10 of EN 1993-1-1, taking into account a reduced yield strength:
 - for $h = 10\text{ m}$: $f_{y,\text{red}} = 0.9 f_y$
 - for $h \leq 4\text{ m}$: $f_{y,\text{red}} = 1.0 f_y$
 - for $4\text{ m} < h < 10\text{ m}$: linear interpolation
- Local plate bending of the flanges is verified according to (3).

(3) Local plate bending in the flanges should be verified for a cross-section through the flange located at the beginning of the fillet taking into account the design forces introduced via the connectors, see Figure D-1, using:

$$\frac{M_{Ed}}{M_{Rd}} + \left(\frac{N_{Ed}}{N_{Rd}} \right)^2 \leq 1 \quad (\text{D.1})$$

where M_{Ed} and N_{Ed} are the design action effects for plate bending, given by

$$M_{Ed} = m_{Ed} + w_{z,Ed} d \quad \text{and} \quad N_{Ed} = w_{y,Ed} \quad (\text{D.2})$$

M_{Rd} and N_{Rd} are the design values of the resistances for plate bending, given by:

$$M_{Rd} = 0,2875 t^2 f_y / \gamma_{M0} \quad \text{and} \quad N_{Rd} = t f_y / \gamma_{M0}$$

where t is the flange thickness at the beginning of the fillet.

NOTE 1: M_{Ed} , N_{Ed} , M_{Rd} and N_{Rd} are to be taken per unit length.

NOTE 2: The shear force interaction may be neglected.

- (4) Reference should be made to EN1993-1-5 for the shear buckling verification of the webs.
- (5) Reference should be made to section 6.3.3 of EN1993-1-1 for the overall buckling verification.

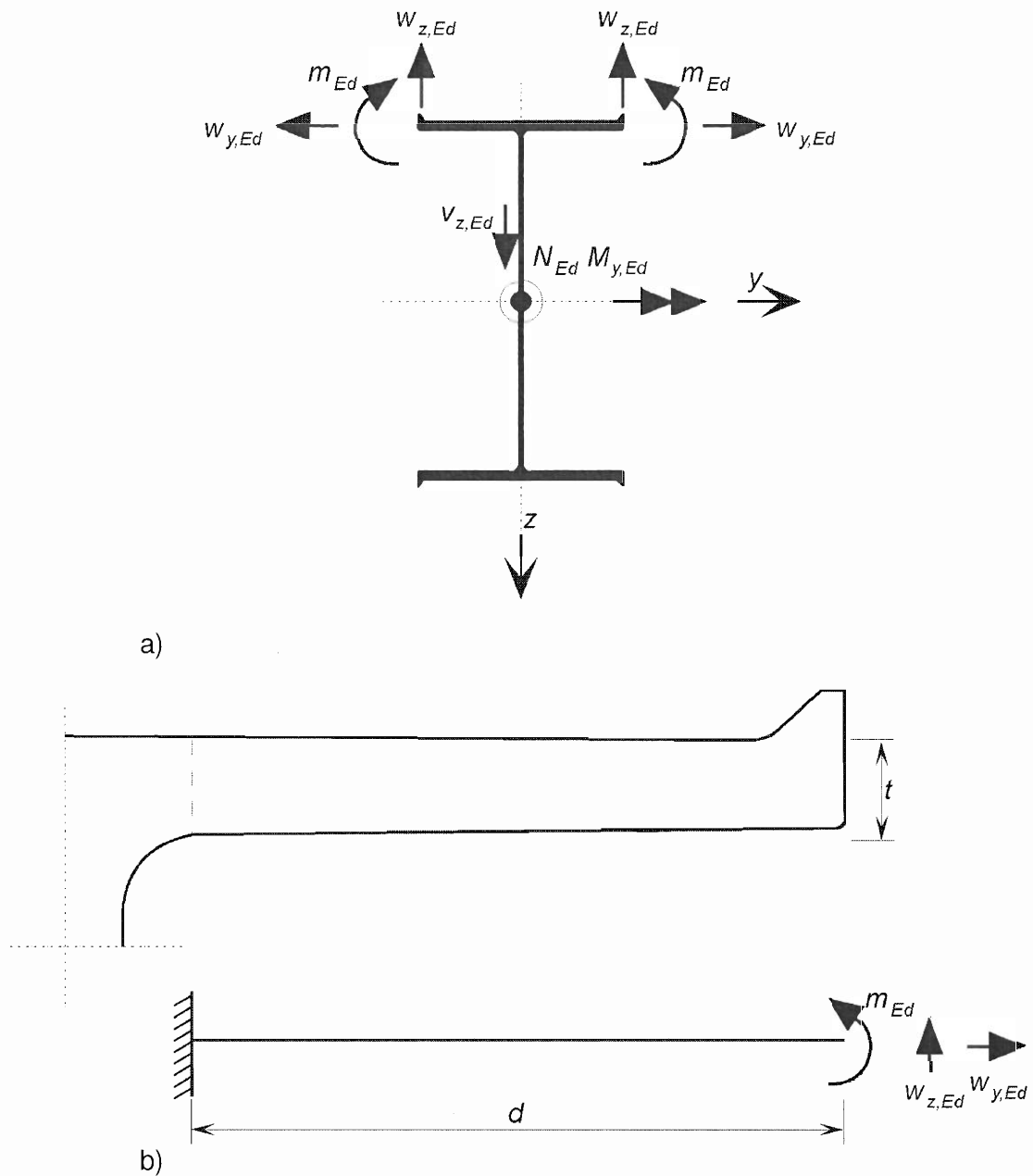

Figure D-1: I-section with overall and plate bending

D.2 Tubular piles used as primary elements

D.2.1 General

(1) Tubular piles used as primary elements in combined walls, which appear to be class 4 sections according to Table 5-2 of EN 1993-1-1, may be verified according to the following procedure.

(2) If the criterion (5.1) in EN 1993-1-1 is not fulfilled, the global internal forces and moments should be determined using a beam model with second order theory.

NOTE: To calculate F_{cr} the effect of the ovalisation on the second moment of area should be taken into account. See 5.2.3 for the determination of the buckling length.

(3) If required by section 5.5.4, the local shell bending stresses and displacements due to the design forces introduced by the secondary elements via the connectors may be estimated from Table D-1.

NOTE 1: The vertical support reactions from Figure 5-9 may be disregarded for the determination of local shell bending stresses.

NOTE 2: For simplification the horizontal forces $w_{y,Ed}$ may be assumed to act only in tension.

(4) The effect of the ovalisation of the tube due to local shell bending on the second moment of area about the wall axis, see Figure D-2, may be estimated using the reduction factor:

$$\beta_{o,I} = 1 - 1,5 (e / r) \quad (D.3)$$

NOTE: The effect of the ovalisation on the section modulus may be neglected.

(5) The ovalisation e due to local shell bending, see Figure D-2 and Table D-1, may be estimated from:

$$e = 0,0684 w_{y,Ed} \frac{r^3}{EI} \quad \text{but} \quad e \leq 0,1 r \quad (D.4)$$

where:

EI is the stiffness for shell bending of the tube, given by:

$$EI = E r^3 / 12;$$

r is the mid-line radius of the tube;

$w_{y,Ed}$ is the support reaction per unit length, determined from 5.5.2(3), see Figure 5-9.

(6) The radius of curvature a at the ovalisation, see Figure D-2, may be obtained from:

$$a = \frac{r}{1 - \frac{3e}{r}} \quad (D.5)$$

Table D-1: Local shell bending due to design forces from secondary elements

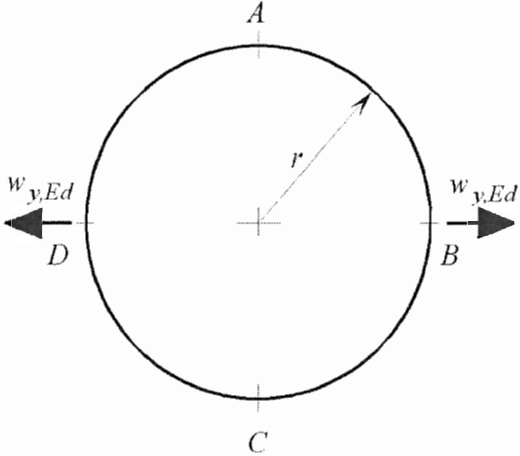
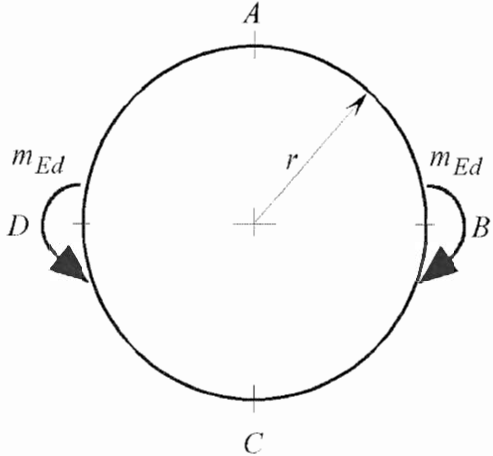
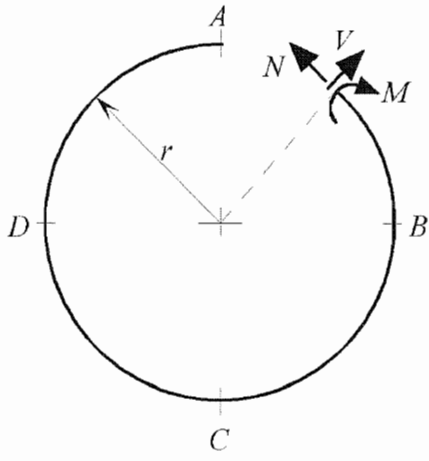
	
$M_A = 0,182 w_{y,Ed} r$ $N_A = 0,5 w_{y,Ed}$ $V_A = 0$ $M_B = -0,318 w_{y,Ed} r$ $N_B = 0$ $V_B = \pm 0,5 w_{y,Ed}$ $\Delta D_{BD} = 0,1488 w_{y,Ed} r^3 / EI$ $\Delta D_{AC} = -0,1368 w_{y,Ed} r^3 / EI$	$M_A = 0,137 m_{Ed}$ $N_A = 0,637 m_{Ed} / r$ $V_A = 0$ $M_B = \pm 0,5 m_{Ed}$ $N_B = 0$ $V_B = -0,637 m_{Ed} / r$ $\Delta D_{BD} = 0$ $\Delta D_{AC} = 0$
<p>Where:</p> <ul style="list-style-type: none"> - M, N and V are the internal forces and moments in shell bending according to the definition given in the figure. - $w_{y,Ed}$ and m_{Ed} are the design forces introduced by the secondary elements via the connecting devices. - ΔD_{BD} and ΔD_{AC} are the changes in diameter resulting from the applied forces (ovalisation). - r is the midline radius of the tube - EI is the shell bending stiffness of the tube 	<p>Definition of internal forces and moments in shell bending:</p> 

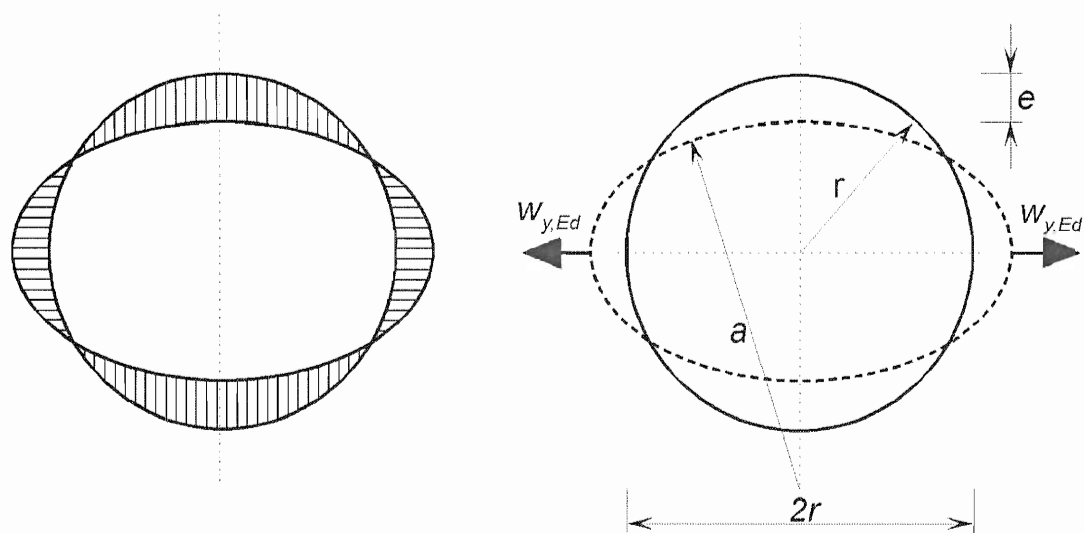

- a : radius of curvature at ovalisation
 e : ovalisation due to local shell bending
 r : midline radius of the tube
 t : wall thickness of the tube
 $W_{y,Ed}$: force introduced by the secondary elements

Figure D-2: Tube pile: geometrical data and local shell bending

D.2.2 Verification method

(1) The following procedure may be used for the verification of the tubular piles taking into account shell buckling, the interaction between overall bending, normal forces, local shell bending and overall buckling.

NOTE: Alternatively the verification may be carried out according to 8.6 or 8.7 of EN1993-1-6 using a model suited for this type of analysis and which gives due consideration to the stiffening effect of the soil. This approach generally yields more economic results than the procedure given below.

(2) The buckling verification should be carried out for a cylindrical shell with a radius equal to the radius of curvature a at the ovalisation.

(3) Reference should be made to section 8.5 of EN1993-1-6 for the buckling verification.

(4) Shear buckling may be neglected at points of load introduction, provided that these points are stiffened by a concrete fill or appropriately designed stiffeners.

(5) If the tube is filled over a certain height with dense sand or stiff clay the circumferential compression stresses due to earth and water pressure may be neglected for the buckling verification in this part of the tube.

NOTE: Information concerning the required density or stiffness may be given in the National Annex based on local experience.

(6) The critical buckling stress should be determined:

- for meridional (axial) stresses according to D.1.2.1 of EN1993-1-6 with $C_x = 1,0$ even for long cylinders;
- according to D.1.4.1 of EN1993-1-6 for shear stresses;

- according to D.1.3.1 of EN1993-1-6 using the boundary conditions of case 3 in Table D-3 or D-4 for circumferential compression stresses.

- (7) The buckling parameters should be determined according to D.1.2.2, D.1.4.2 and D.1.3.2 of EN1993-1-6 respectively, taking into account quality class B for new tubes.
- (8) The design values of stresses should be calculated using membrane theory in accordance with Annex A of EN1993-1-6.
- (9) Reference should be made to section 8.5.3 of EN1993-1-6 for verification of the buckling strength.

NOTE 1: If the circumferential compressive stresses have to be taken into account for the buckling verification, non-uniform pressure distributions should be replaced by uniform distributions based on the maximum value.

NOTE 2: Shear may be neglected in the interaction check according to (3) of section 8.5.3 of EN 1993-1-6.

- (10) The general cross-sectional verification should be carried out according to 6.2.1 of EN1993-1-1 using the procedure given in section 6.2 of EN1993-1-6. For this verification the stresses due to both overall bending and local shell bending according to Table D-1 should be taken into account. The effect of ovalisation may be neglected and the full elastic cross-sectional properties may be used for this verification. The critical points where the yield criterion should be applied, should be determined taking into account the governing cross-sections and the governing points in those cross-sections (points A, B, C and D in Table D-1).

- (11) For the overall buckling verification reference should be made to section 6.3.3 of EN1993-1-1 using full elastic cross-sectional properties, taking into account the effect of ovalisation in accordance with (4) of D.2.1.

- (12) This verification may be deemed to be satisfied by verifying the interaction criterion:

$$\frac{N_{Ed}}{\chi N_{Rk}} + 1,5 \frac{M_{Ed}}{\gamma_{M1} M_{Rk}} \leq 1,0 \quad (D.6)$$

where: N_{Ed} and M_{Ed} are the design values of the compressive force and the bending moment in the governing cross-section;

N_{Rk} and M_{Rk} are the characteristic resistances, determined in accordance with (11);

χ is the reduction factor due to overall flexural buckling taken from 6.3.1.2 of EN1993-1-1, based on a buckling length in accordance with 5.2.3.

NOTE: The slenderness should be determined according to 6.3.1.3 of EN1993-1-1, taking into account (2) of D.2.1.

