

The European Union

EDICT OF GOVERNMENT

In order to promote public education and public safety, equal justice for all, a better informed citizenry, the rule of law, world trade and world peace, this legal document is hereby made available on a noncommercial basis, as it is the right of all humans to know and speak the laws that govern them.

EN 1993-1-8 (2005) (English): Eurocode 3: Design of steel structures - Part 1-8: Design of joints [Authority: The European Union Per Regulation 305/2011, Directive 98/34/EC, Directive 2004/18/EC]



BLANK PAGE



EUROPEAN STANDARD

EN 1993-1-8

NORME EUROPÉENNE

EUROPÄISCHE NORM

May 2005

ICS 91.010.30

Supersedes ENV 1993-1-1:1992
Incorporating Corrigenda
December 2005 and July 2009

English version

Eurocode 3: Design of steel structures - Part 1-8: Design of joints

Eurocode 3: Calcul des structures en acier - Partie 1-8:
Calcul des assemblages

Eurocode 3: Bemessung und Konstruktion von Stahlbauten
- Teil 1-8: Bemessung von Anschlüssen

This European Standard was approved by CEN on 16 April 2004.

CEN members are bound to comply with the CEN/CENELEC Internal Regulations which stipulate the conditions for giving this European Standard the status of a national standard without any alteration. Up-to-date lists and bibliographical references concerning such national standards may be obtained on application to the Central Secretariat or to any CEN member.

This European Standard exists in three official versions (English, French, German). A version in any other language made by translation under the responsibility of a CEN member into its own language and notified to the Central Secretariat has the same status as the official versions.

CEN members are the national standards bodies of Austria, Belgium, Cyprus, Czech Republic, Denmark, Estonia, Finland, France, Germany, Greece, Hungary, Iceland, Ireland, Italy, Latvia, Lithuania, Luxembourg, Malta, Netherlands, Norway, Poland, Portugal, Slovakia, Slovenia, Spain, Sweden, Switzerland and United Kingdom.



EUROPEAN COMMITTEE FOR STANDARDIZATION
COMITÉ EUROPÉEN DE NORMALISATION
EUROPÄISCHES KOMITEE FÜR NORMUNG

Management Centre: rue de Stassart, 36 B-1050 Brussels

Contents	Page
1 Introduction	8
1.1 Scope	8
1.2 Normative references.....	8
1.3 Distinction between Principles and Application Rules	10
1.4 Terms and definitions	10
1.5 Symbols	13
2 Basis of design.....	18
2.1 Assumptions	18
2.2 General requirements.....	18
2.3 Applied forces and moments	18
2.4 Resistance of joints.....	18
2.5 Design assumptions	19
2.6 Joints loaded in shear subject to impact, vibration and/or load reversal	19
2.7 Eccentricity at intersections.....	19
3 Connections made with bolts, rivets or pins.....	20
3.1 Bolts, nuts and washers	20
3.1.1 General	20
3.1.2 Preloaded bolts	20
3.2 Rivets.....	20
3.3 Anchor bolts	21
3.4 Categories of bolted connections.....	21
3.4.1 Shear connections.....	21
3.4.2 Tension connections	21
3.5 Positioning of holes for bolts and rivets	23
3.6 Design resistance of individual fasteners	24
3.6.1 Bolts and rivets	24
3.6.2 Injection bolts	28
3.7 Group of fasteners	29
3.8 Long joints.....	29
3.9 Slip-resistant connections using 8.8 or 10.9 bolts	30
3.9.1 Design Slip resistance.....	30
3.9.2 Combined tension and shear.....	31
3.9.3 Hybrid connections.....	31
3.10 Deductions for fastener holes	31
3.10.1 General	31
3.10.2 Design for block tearing	32
3.10.3 Angles connected by one leg and other unsymmetrically connected members in tension.....	33
3.10.4 Lug angles	34
3.11 Prying forces.....	34
3.12 Distribution of forces between fasteners at the ultimate limit state.....	34
3.13 Connections made with pins.....	35
3.13.1 General	35
3.13.2 Design of pins.....	35
4 Welded connections	38
4.1 General	38
4.2 Welding consumables.....	38
4.3 Geometry and dimensions	38
4.3.1 Type of weld.....	38
4.3.2 Fillet welds	38
4.3.3 Fillet welds all round.....	40
4.3.4 Butt welds.....	40
4.3.5 Plug welds	41

4.3.6	Flare groove welds.....	41
4.4	Welds with packings.....	41
4.5	Design resistance of a fillet weld.....	42
4.5.1	Length of welds.....	42
4.5.2	Effective throat thickness.....	42
4.5.3	Design Resistance of fillet welds.....	42
4.6	Design resistance of fillet welds all round.....	44
4.7	Design resistance of butt welds.....	45
4.7.1	Full penetration butt welds.....	45
4.7.2	Partial penetration butt welds.....	45
4.7.3	T-butt joints.....	45
4.8	Design resistance of plug welds.....	45
4.9	Distribution of forces.....	46
4.10	Connections to unstiffened flanges.....	46
4.11	Long joints.....	48
4.12	Eccentrically loaded single fillet or single-sided partial penetration butt welds.....	48
4.13	Angles connected by one leg.....	48
4.14	Welding in cold-formed zones.....	49
5	Analysis, classification and modelling.....	50
5.1	Global analysis.....	50
5.1.1	General.....	50
5.1.2	Elastic global analysis.....	50
5.1.3	Rigid-plastic global analysis.....	51
5.1.4	Elastic- plastic global analysis.....	51
5.1.5	Global analysis of lattice girders.....	52
5.2	Classification of joints.....	54
5.2.1	General.....	54
5.2.2	Classification by stiffness.....	54
5.2.3	Classification by strength.....	55
5.3	Modelling of beam-to-column joints.....	56
6	Structural joints connecting H or I sections.....	60
6.1	General.....	60
6.1.1	Basis.....	60
6.1.2	Structural properties.....	60
6.1.3	Basic components of a joint.....	61
6.2	Design Resistance.....	65
6.2.1	Internal forces.....	65
6.2.2	Shear forces.....	65
6.2.3	Bending moments.....	66
6.2.4	Equivalent T-stub in tension.....	67
6.2.5	Equivalent T-stub in compression.....	70
6.2.6	Design Resistance of basic components.....	71
6.2.7	Design moment resistance of beam-to-column joints and splices.....	84
6.2.8	Design resistance of column bases with base plates.....	89
6.3	Rotational stiffness.....	92
6.3.1	Basic model.....	92
6.3.2	Stiffness coefficients for basic joint components.....	94
6.3.3	End-plate joints with two or more bolt-rows in tension.....	97
6.3.4	Column bases.....	98
6.4	Rotation capacity.....	99
6.4.1	General.....	99
6.4.2	Bolted joints.....	100
6.4.3	Welded Joints.....	100
7	Hollow section joints.....	101
7.1	General.....	101

BS EN 1993-1-8:2005
EN 1993-1-8:2005 (E)

7.1.1	Scope	101
7.1.2	Field of application.....	101
7.2	Design.....	103
7.2.1	General	103
7.2.2	Failure modes for hollow section joints.....	103
7.3	Welds.....	107
7.3.1	Design resistance	107
7.4	Welded joints between CHS members	108
7.4.1	General	108
7.4.2	Uniplanar joints	108
7.4.3	Multiplanar joints	115
7.5	Welded joints between CHS or RHS brace members and RHS chord members	116
7.5.1	General	116
7.5.2	Uniplanar joints	117
7.5.3	Multiplanar joints	128
7.6	Welded joints between CHS or RHS brace members and I or H section chords	129
7.7	Welded joints between CHS or RHS brace members and channel section chord members	132

Foreword

This European Standard EN 1993, Eurocode 3: Design of steel structures, has been prepared by Technical Committee CEN/TC250 « Structural Eurocodes », the Secretariat of which is held by BSI. CEN/TC250 is responsible for all Structural Eurocodes.

This European Standard shall be given the status of a National Standard, either by publication of an identical text or by endorsement, at the latest by November 2005, and conflicting National Standards shall be withdrawn at latest by March 2010.

This Eurocode supersedes ENV 1993-1-1.

According to the CEN-CENELEC Internal Regulations, the National Standard Organizations of the following countries are bound to implement these European Standard: Austria, Belgium, Cyprus, Czech Republic, Denmark, Estonia, Finland, France, Germany, Greece, Hungary, Iceland, Ireland, Italy, Latvia, Lithuania, Luxembourg, Malta, Netherlands, Norway, Poland, Portugal, Slovakia, Slovenia, Spain, Sweden, Switzerland and United Kingdom.

Background to the Eurocode programme

In 1975, the Commission of the European Community decided on an action programme in the field of construction, based on article 95 of the Treaty. The objective of the programme was the elimination of technical obstacles to trade and the harmonization of technical specifications.

Within this action programme, the Commission took the initiative to establish a set of harmonized technical rules for the design of construction works which, in a first stage, would serve as an alternative to the national rules in force in the Member States and, ultimately, would replace them.

For fifteen years, the Commission, with the help of a Steering Committee with Representatives of Member States, conducted the development of the Eurocodes programme, which led to the first generation of European codes in the 1980s.

In 1989, the Commission and the Member States of the EU and EFTA decided, on the basis of an agreement¹ between the Commission and CEN, to transfer the preparation and the publication of the Eurocodes to CEN through a series of Mandates, in order to provide them with a future status of European Standard (EN). This links *de facto* the Eurocodes with the provisions of all the Council's Directives and/or Commission's Decisions dealing with European standards (e.g. the Council Directive 89/106/EEC on construction products - CPD - and Council Directives 93/37/EEC, 92/50/EEC and 89/440/EEC on public works and services and equivalent EFTA Directives initiated in pursuit of setting up the internal market).

The Structural Eurocode programme comprises the following standards generally consisting of a number of Parts:

EN 1990	Eurocode 0:	Basis of Structural Design
EN 1991	Eurocode 1:	Actions on structures
EN 1992	Eurocode 2:	Design of concrete structures
EN 1993	Eurocode 3:	Design of steel structures
EN 1994	Eurocode 4:	Design of composite steel and concrete structures
EN 1995	Eurocode 5:	Design of timber structures
EN 1996	Eurocode 6:	Design of masonry structures
EN 1997	Eurocode 7:	Geotechnical design
EN 1998	Eurocode 8:	Design of structures for earthquake resistance
EN 1999	Eurocode 9:	Design of aluminium structures

¹ Agreement between the Commission of the European Communities and the European Committee for Standardisation (CEN) concerning the work on EUROCODES for the design of building and civil engineering works (BC/CEN/03/89).

BS EN 1993-1-8:2005 **EN 1993-1-8:2005 (E)**

Eurocode standards recognize the responsibility of regulatory authorities in each Member State and have safeguarded their right to determine values related to regulatory safety matters at national level where these continue to vary from State to State.

Status and field of application of eurocodes

The Member States of the EU and EFTA recognize that Eurocodes serve as reference documents for the following purposes :

- as a means to prove compliance of building and civil engineering works with the essential requirements of Council Directive 89/106/EEC, particularly Essential Requirement N°1 – Mechanical resistance and stability – and Essential Requirement N°2 – Safety in case of fire;
- as a basis for specifying contracts for construction works and related engineering services;
- as a framework for drawing up harmonized technical specifications for construction products (ENs and ETAs)

The Eurocodes, as far as they concern the construction works themselves, have a direct relationship with the Interpretative Documents² referred to in Article 12 of the CPD, although they are of a different nature from harmonized product standards³. Therefore, technical aspects arising from the Eurocodes work need to be adequately considered by CEN Technical Committees and/or EOTA Working Groups working on product standards with a view to achieving full compatibility of these technical specifications with the Eurocodes.

The Eurocode standards provide common structural design rules for everyday use for the design of whole structures and component products of both a traditional and an innovative nature. Unusual forms of construction or design conditions are not specifically covered and additional expert consideration will be required by the designer in such cases.

National Standards implementing Eurocodes

The National Standards implementing Eurocodes will comprise the full text of the Eurocode (including any annexes), as published by CEN, which may be preceded by a National title page and National foreword, and may be followed by a National annex.

The National annex may only contain information on those parameters which are left open in the Eurocode for national choice, known as Nationally Determined Parameters, to be used for the design of buildings and civil engineering works to be constructed in the country concerned, *i.e.* :

- values and/or classes where alternatives are given in the Eurocode,
- values to be used where a symbol only is given in the Eurocode,
- country specific data (geographical, climatic, etc.), *e.g.* snow map,
- the procedure to be used where alternative procedures are given in the Eurocode.

It may contain

- decisions on the application of informative annexes,
- references to non-contradictory complementary information to assist the user to apply the Eurocode.

Links between Eurocodes and harmonized technical specifications (ENs and ETAs) for products

² According to Art. 3.3 of the CPD, the essential requirements (ERs) shall be given concrete form in interpretative documents for the creation of the necessary links between the essential requirements and the mandates for harmonized ENs and ETAGs/ETAs.

³ According to Art. 12 of the CPD the interpretative documents shall :

- a) give concrete form to the essential requirements by harmonizing the terminology and the technical bases and indicating classes or levels for each requirement where necessary ;
- b) indicate methods of correlating these classes or levels of requirement with the technical specifications, *e.g.* methods of calculation and of proof, technical rules for project design, etc. ;
- c) serve as a reference for the establishment of harmonized standards and guidelines for European technical approvals.

The Eurocodes, *de facto*, play a similar role in the field of the ER 1 and a part of ER 2.

There is a need for consistency between the harmonized technical specifications for construction products and the technical rules for works⁴. Furthermore, all the information accompanying the CE Marking of the construction products which refer to Eurocodes should clearly mention which Nationally Determined Parameters have been taken into account.

National annex for EN 1993-1-8

This standard gives alternative procedures, values and recommendations with notes indicating where national choices may have to be made. The National Standard implementing EN 1993-1-8 should have a National Annex containing all Nationally Determined Parameters for the design of steel structures to be constructed in the relevant country.

National choice is allowed in EN 1993-1-8 through:

- 2.2(2)
- 1.2.6 (Group 6: Rivets)
- 3.1.1(3)
- 3.4.2(1)
- 5.2.1(2)
- 6.2.7.2(9)

⁴ see Art.3.3 and Art.12 of the CPD, as well as clauses 4.2, 4.3.1, 4.3.2 and 5.2 of ID 1.

1 Introduction

1.1 Scope

- (1) This part of EN 1993 gives design methods for the design of joints subject to predominantly static loading using steel grades S235, S275, $\overline{AC2}$ S355, S420, S450 and S460 $\overline{AC2}$.

1.2 Normative references

This European Standard incorporates by dated or undated reference, provisions from other publications. These normative references are cited at the appropriate places in the text and the publications are listed hereafter. For dated references, subsequent amendments to or revisions of any of these publications apply to this European Standard, only when incorporated in it by amendment or revision. For undated references the latest edition of the publication referred to applies (including amendments).

1.2.1 Reference Standards, Group 1: Weldable structural steels

EN 10025-1:2004	Hot rolled products of structural steels. General technical delivery conditions
EN 10025-2:2004	Hot rolled products of structural steels. Technical delivery conditions for non-alloy structural steels
EN 10025-3:2004	Hot rolled products of structural steels. Technical delivery conditions for normalized/normalized rolled weldable fine grain structural steels
EN 10025-4:2004	Hot rolled products of structural steels. Technical delivery conditions for thermomechanical rolled weldable fine grain structural steels
EN 10025-5:2004	Hot rolled products of structural steels. Technical delivery conditions for structural steels with improved atmospheric corrosion resistance
EN 10025-6:2004	Hot rolled products of structural steels. Technical delivery conditions for flat products of high yield strength structural steels in quenched and tempered condition

1.2.2 Reference Standards, Group 2: Tolerances, dimensions and technical delivery conditions

EN 10029:1991	Hot rolled steel plates 3 mm thick or above - Tolerances on dimensions, shape and mass
EN 10034:1993	Structural steel I- and H-sections - Tolerances on shape and dimensions
EN 10051:1991	Continuously hot-rolled uncoated plate, sheet and strip of non-alloy and alloy steels - Tolerances on dimensions and shape
EN 10055:1995	Hot rolled steel equal flange tees with radiused root and toes - Dimensions and tolerances on shape and dimensions
EN 10056-1:1995	Structural steel equal and unequal leg angles - Part 1: Dimensions
EN 10056-2:1993	Structural steel equal and unequal leg angles - Part 2: Tolerances on shape and dimensions
EN 10164:1993	Steel products with improved deformation properties perpendicular to the surface of the product - Technical delivery conditions

1.2.3 Reference Standards, Group 3: Structural hollow sections

EN 10219-1:1997	Cold formed welded structural hollow sections of non-alloy and fine grain steels - Part 1: Technical delivery requirements
-----------------	--

EN 10219-2:1997	Cold formed welded structural hollow sections of non-alloy and fine grain steels - Part 2: Tolerances, dimensions and sectional properties
EN 10210-1:1994	Hot finished structural hollow sections of non-alloy and fine grain structural steels - Part 1: Technical delivery requirements
EN 10210-2:1997	Hot finished structural hollow sections of non-alloy and fine grain structural steels - Part 2: Tolerances, dimensions and sectional properties

1.2.4 Reference Standards, Group 4: Bolts, nuts and washers

EN 14399-1:2002	High strength structural bolting for preloading - Part 1 : General Requirements
EN 14399-2:2002	High strength structural bolting for preloading - Part 2 : Suitability Test for preloading
EN 14399-3:2002	High strength structural bolting for preloading - Part 3 : System HR -Hexagon bolt and nut assemblies
EN 14399-4:2002	High strength structural bolting for preloading - Part 4 : System HV -Hexagon bolt and nut assemblies
EN 14399-5:2002	High strength structural bolting for preloading - Part 5 : Plain washers for system HR
EN 14399-6:2002	High strength structural bolting for preloading - Part 6 : Plain chamfered washers for systems HR and HV
EN ISO 898-1:1999	Mechanical properties of fasteners made of carbon steel and alloy steel - Part 1: Bolts, screws and studs (ISO 898-1:1999)
EN 20898-2:1993	Mechanical properties of fasteners - Part 2: Nuts with special proof load values - Coarse thread (ISO 898-2:1992)
EN ISO 2320:1997	Prevailing torque type steel hexagon nuts - Mechanical and performance requirements (ISO 2320:1997)
EN ISO 4014:2000	Hexagon head bolts - Product grades A and B (ISO 4014:1999)
EN ISO 4016:2000	Hexagon head bolts - Product grade C (ISO 4016:1999)
EN ISO 4017:2000	Hexagon head screws - Product grades A and B (ISO 4017:1999)
EN ISO 4018:2000	Hexagon head screws - Product grade C (ISO 4018:1999)
EN ISO 4032:2000	Hexagon nuts, style 1 - Product grades A and B (ISO 4032:1999)
EN ISO 4033:2000	Hexagon nuts, style 2 - Product grades A and B (ISO 4033:1999)
EN ISO 4034:2000	Hexagon nuts - Product grade C (ISO 4034:1999)
EN ISO 7040:1997	Prevailing torque hexagon nuts (with non-metallic insert), style 1 - Property classes 5, 8 and 10
EN ISO 7042:1997	Prevailing torque all-metal hexagon nuts, style 2 - Property classes 5, 8, 10 and 12
EN ISO 7719:1997	Prevailing torque type all-metal hexagon nuts, style 1 - Property classes 5, 8 and 10
ISO 286- 2:1988	ISO system of limits and fits - Part 2: Tables of standard tolerance grades and limit deviations for hole and shafts
ISO 1891:1979	Bolts, screws, nuts and accessories - Terminology and nomenclature - Trilingual edition
EN ISO 7089:2000	Plain washers- Nominal series- Product grade A
EN ISO 7090:2000	Plain washers, chamfered - Normal series - Product grade A
EN ISO 7091:2000	Plain washers - Normal series - Product grade C
EN ISO 10511:1997	Prevailing torque type hexagon thin nuts (with non-metallic insert)
EN ISO 10512:1997	Prevailing torque type hexagon nuts thin nuts, style 1, with metric fine pitch thread - Property classes 6, 8 and 10
EN ISO 10513:1997	Prevailing torque type all-metal hexagon nuts, style 2, with metric fine pitch thread - Property classes 8, 10 and 12

1.2.5 Reference Standards, Group 5: Welding consumable and welding

- EN 12345:1998 Welding-Multilingual terms for welded joints with illustrations. September 1998.
EN ISO 14555:1998 Welding-Arc stud welding of metallic materials. May 1995
EN ISO 13918:1998 Welding-Studs for arc stud welding-January 1997
EN 288-3:1992 Specification and approval of welding procedures for metallic materials. Part 3: Welding procedure tests for arc welding of steels. 1992
EN ISO 5817:2003 Arc-welded joints in steel - Guidance for quality levels for imperfections

1.2.6 Reference Standards, Group 6: Rivets

NOTE: Information may be given in the National Annex.

1.2.7 Reference Standard, Group 7: Execution of steel structures

- EN 1090-2 Requirements for the execution of steel structures

1.3 Distinction between Principles and Application Rules

- (1) The rules in EN 1990 clause 1.4 apply.

1.4 Terms and definitions

- (1) The following terms and definitions apply:

1.4.1

basic component (of a joint)

Part of a joint that makes a contribution to one or more of its structural properties.

1.4.2

connection

Location at which two or more elements meet. For design purposes it is the assembly of the basic components required to represent the behaviour during the transfer of the relevant internal forces and moments at the connection.

1.4.3

connected member

Any member that is joined to a supporting member or element.

1.4.4

joint

Zone where two or more members are interconnected. For design purposes it is the assembly of all the basic components required to represent the behaviour during the transfer of the relevant internal forces and moments between the connected members. A beam-to-column joint consists of a web panel and either one connection (single sided joint configuration) or two connections (double sided joint configuration), see Figure 1.1.

1.4.5

joint configuration

Type or layout of the joint or joints in a zone within which the axes of two or more inter-connected members intersect, see Figure 1.2.

1.4.6

rotational capacity

The angle through which the joint can rotate for a given resistance level without failing.

1.4.7

rotational stiffness

The moment required to produce unit rotation in a joint.

1.4.8

structural properties (of a joint)

Resistance to internal forces and moments in the connected members, rotational stiffness and rotation capacity.

1.4.9

uniplanar joint

In a lattice structure a uniplanar joint connects members that are situated in a single plane.

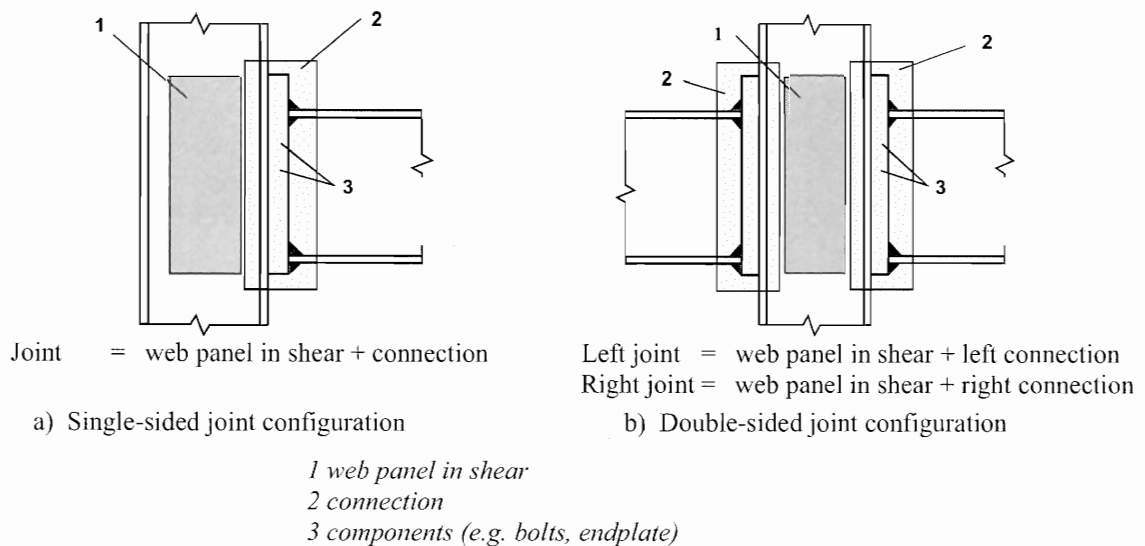
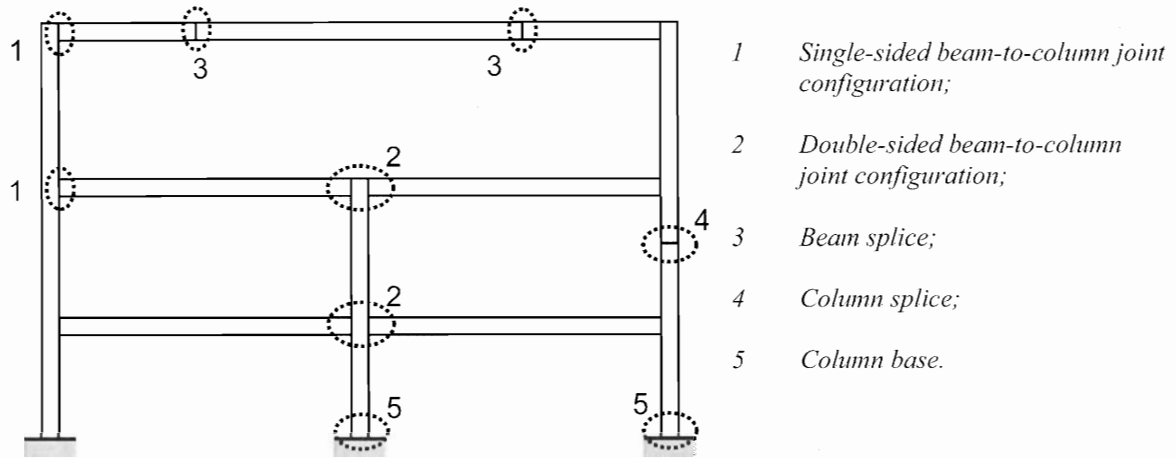
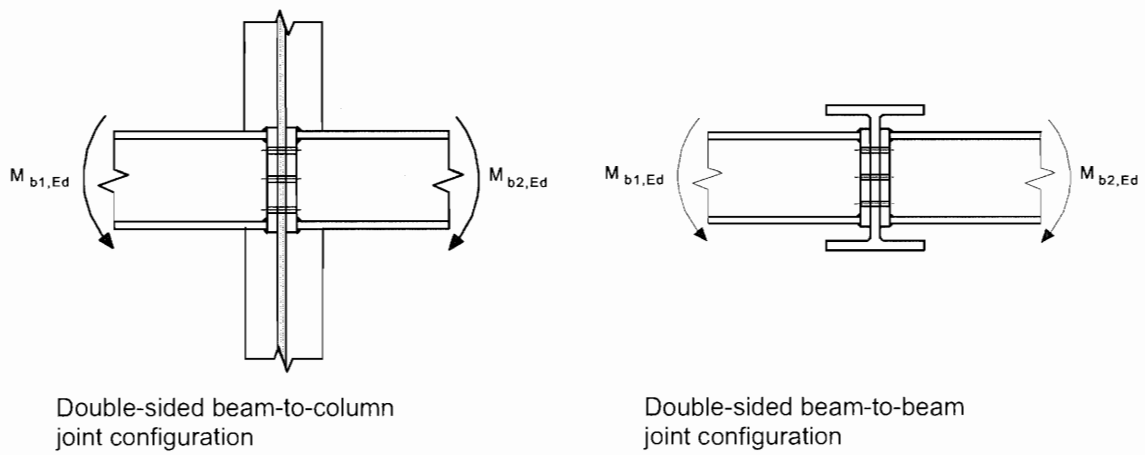


Figure 1.1: Parts of a beam-to-column joint configuration



a) Major-axis joint configurations



b) Minor-axis joint configurations (to be used only for balanced moments $M_{b1,Ed} = M_{b2,Ed}$)

Figure 1.2: Joint configurations

1.5 Symbols

(1) The following symbols are used in this Standard:

- d is the nominal bolt diameter, the diameter of the pin or the diameter of the fastener;
- d_0 is the hole diameter for a bolt, a rivet or a pin ;
- $d_{0,t}$ is the hole size for the tension face, generally the hole diameter, but for a slotted holes perpendicular to the tension face the slot length should be used;
- $d_{0,v}$ is the hole size for the shear face, generally the hole diameter, but for slotted holes parallel to the shear face the slot length should be used;
- d_c is the clear depth of the column web;
- d_m is the mean of the across points and across flats dimensions of the bolt head or the nut, whichever is smaller;
- $f_{H,Rd}$ is the design value of the Hertz pressure;
- f_{ur} is the specified ultimate tensile strength of the rivet;
- e_1 is the end distance from the centre of a fastener hole to the adjacent end of any part, measured in the direction of load transfer, see Figure 3.1;
- e_2 is the edge distance from the centre of a fastener hole to the adjacent edge of any part, measured at right angles to the direction of load transfer, see Figure 3.1;
- e_3 is the distance from the axis of a slotted hole to the adjacent end or edge of any part, see Figure 3.1;
- e_4 is the distance from the centre of the end radius of a slotted hole to the adjacent end or edge of any part, see Figure 3.1;
- l_{eff} is the effective length of fillet weld;
- n is the number of the friction surfaces or the number of fastener holes on the shear face;
- p_1 is the spacing between centres of fasteners in a line in the direction of load transfer, see Figure 3.1;
- $p_{1,0}$ is the spacing between centres of fasteners in an outer line in the direction of load transfer, see Figure 3.1;
- $p_{1,i}$ is the spacing between centres of fasteners in an inner line in the direction of load transfer, see Figure 3.1;
- p_2 is the spacing measured perpendicular to the load transfer direction between adjacent lines of fasteners, see Figure 3.1;
- r is the bolt row number;

NOTE: In a bolted connection with more than one bolt-row in tension, the bolt-rows are numbered starting from the bolt-row furthest from the centre of compression.

- s_s is the length of stiff bearing;
- t_a is the thickness of the angle cleat;
- t_{fc} is the thickness of the column flange;
- t_p is the thickness of the plate under the bolt or the nut;
- t_w is the thickness of the web or bracket;
- t_{wc} is the thickness of the column web;
- A is the gross cross-section area of bolt;
- A_0 is the area of the rivet hole;
- A_{vc} is the shear area of the column, see EN 1993-1-1;
- A_s is the tensile stress area of the bolt or of the anchor bolt;

BS EN 1993-1-8:2005
EN 1993-1-8:2005 (E)

- $A_{v,eff}$ is the effective shear area;
- $B_{p,Rd}$ is the design punching shear resistance of the bolt head and the nut
- E is the elastic modulus;
- $F_{p,Cd}$ is the design preload force;
- $F_{t,Ed}$ is the design tensile force per bolt for the ultimate limit state;
- $F_{t,Rd}$ is the design tension resistance per bolt;
- $F_{T,Rd}$ is the tension resistance of an equivalent T-stub flange;
- $F_{v,Rd}$ is the design shear resistance per bolt;
- $F_{b,Rd}$ is the design bearing resistance per bolt;
- $F_{s,Rd,ser}$ is the design slip resistance per bolt at the serviceability limit state;
- $F_{s,Rd}$ is the design slip resistance per bolt at the ultimate limit state;
- $F_{v,Ed,ser}$ is the design shear force per bolt for the serviceability limit state;
- $F_{v,Ed}$ is the design shear force per bolt for the ultimate limit state;
- $M_{j,Rd}$ is the design moment resistance of a joint;
- S_j is the rotational stiffness of a joint;
- $S_{j,ini}$ is the initial rotational stiffness of a joint;
- $V_{wp,Rd}$ is the plastic shear resistance of a column web panel;
- z is the lever arm;
- μ is the slip factor;
- ϕ is the rotation of a joint.

(2) The following standard abbreviations for hollow sections are used in section 7:

CHS for “circular hollow section”;

RHS for “rectangular hollow section”, which in this context includes square hollow sections.

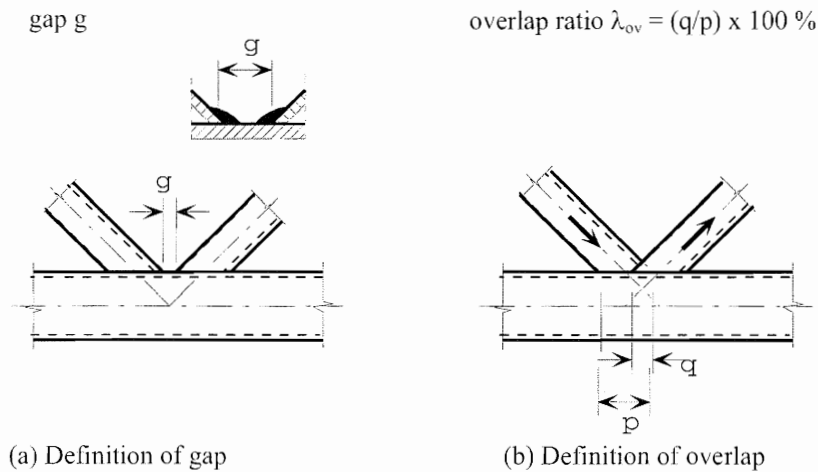


Figure 1.3: Gap and overlap joints

(3) The following symbols are used in section 7:

- A_i is the cross-sectional area of member i ($i = 0, 1, 2$ or 3);
- A_v is the shear area of the chord;
- $A_{v,eff}$ is the effective shear area of the chord;

- L is the system length of a member;
- $M_{ip,i,Rd}$ is the design value of the resistance of the joint, expressed in terms of the in-plane internal moment in member i ($i = 0, 1, 2$ or 3);
- $M_{ip,i,Ed}$ is the design value of the in-plane internal moment in member i ($i = 0, 1, 2$ or 3);
- $M_{op,i,Rd}$ is the design value of the resistance of the joint, expressed in terms of the out-of-plane internal moment in member i ($i = 0, 1, 2$ or 3);
- $M_{op,i,Ed}$ is the design value of the out-of-plane internal moment in member i ($i = 0, 1, 2$ or 3);
- $N_{i,Rd}$ is the design value of the resistance of the joint, expressed in terms of the internal axial force in member i ($i = 0, 1, 2$ or 3);
- $N_{i,Ed}$ is the design value of the internal axial force in member i ($i = 0, 1, 2$ or 3);
- $W_{ef,i}$ is the elastic section modulus of member i ($i = 0, 1, 2$ or 3);
- $W_{pf,i}$ is the plastic section modulus of member i ($i = 0, 1, 2$ or 3);
- b_i is the overall out-of-plane width of RHS member i ($i = 0, 1, 2$ or 3);
- b_{eff} is the effective width for a brace member to chord connection;
- $b_{e,ov}$ is the effective width for an overlapping brace to overlapped brace connection;
- $b_{c,p}$ is the effective width for punching shear;
- b_p is the width of a plate;
- b_w is the effective width for the web of the chord;
- d_i is the overall diameter of CHS member i ($i = 0, 1, 2$ or 3);
- d_w is the depth of the web of an I or H section chord member;
- e is the eccentricity of a joint;
- f_b is the buckling strength of the chord side wall;
- f_{yi} is the yield strength of member i ($i = 0, 1, 2$ or 3);
- f_{y0} is the yield strength of a chord member;
- g is the gap between the brace members in a K or N joint (negative values of g represent an overlap q); the gap g is measured along the length of the connecting face of the chord, between the toes of the adjacent brace members, see Figure 1.3(a);
- h_i is the overall in-plane depth of the cross-section of member i ($i = 0, 1, 2$ or 3);
- $\boxed{AC2} h_z$ is the distance between centres of gravity of the effective width parts of a rectangular section beam connected to a I or H section column; $\boxed{AC2}$
- k is a factor defined in the relevant table, with subscript g, m, n or p ;
- ℓ is the buckling length of a member;
- p is the length of the projected contact area of the overlapping brace member onto the face of the chord, in the absence of the overlapped brace member, see Figure 1.3(b);
- q is the length of overlap, measured at the face of the chord, between the brace members in a K or N joint, see Figure 1.3(b);
- r is the root radius of an I or H section or the corner radius of a rectangular hollow section;
- t_f is the flange thickness of an I or H section;
- t_i is the wall thickness of member i ($i = 0, 1, 2$ or 3);
- t_p is the thickness of a plate;
- t_w is the web thickness of an I or H section;
- α is a factor defined in the relevant table;
- θ_i is the included angle between brace member i and the chord ($i = 1, 2$ or 3);
- κ is a factor defined where it occurs;
- μ is a factor defined in the relevant table;
- φ is the angle between the planes in a multiplanar joint.

(4) The integer subscripts used in section 7 are defined as follows:

i is an integer subscript used to designate a member of a joint, $i = 0$ denoting a chord and $i = 1, 2$ or 3 the brace members. In joints with two brace members, $i = 1$ normally denotes the compression brace and $i = 2$ the tension brace, see Figure 1.4(b). For a single brace $i = 1$ whether it is subject to compression or tension, see Figure 1.4(a);

i and j are integer subscripts used in overlap type joints, i to denote the overlapping brace member and j to denote the overlapped brace member, see Figure 1.4(c).

(5) The stress ratios used in section 7 are defined as follows:

n is the ratio $(\sigma_{0,Ed}/f_{y0})/\gamma_{M5}$ (used for RHS chords);

n_p is the ratio $(\sigma_{p,Ed}/f_{y0})/\gamma_{M5}$ (used for CHS chords);

$\sigma_{0,Ed}$ is the maximum compressive stress in the chord at a joint;

$\sigma_{p,Ed}$ is the value of $\sigma_{0,Ed}$ excluding the stress due to the components parallel to the chord axis of the axial forces in the braces at that joint, see Figure 1.4.

(6) The geometric ratios used in section 7 are defined as follows:

β is the ratio of the mean diameter or width of the brace members, to that of the chord:

- for T, Y and X joints:

$$\frac{d_1}{d_0}; \frac{d_1}{b_0} \text{ or } \frac{b_1}{b_0}$$

- for K and N joints:

$$\frac{d_1 + d_2}{2 d_0}; \frac{d_1 + d_2}{2 b_0} \text{ or } \frac{b_1 + b_2 + h_1 + h_2}{4 b_0}$$

- for KT joints:

$$\frac{d_1 + d_2 + d_3}{3 d_0}; \frac{d_1 + d_2 + d_3}{3 b_0} \text{ or } \frac{b_1 + b_2 + b_3 + h_1 + h_2 + h_3}{6 b_0}$$

β_p is the ratio b_i/b_p ;

γ is the ratio of the chord width or diameter to twice its wall thickness:

$$\frac{d_0}{2 t_0}; \frac{b_0}{2 t_0} \text{ or } \frac{b_0}{2 t_f}$$

η is the ratio of the brace member depth to the chord diameter or width:

$$\frac{h_i}{d_0} \text{ or } \frac{h_i}{b_0}$$

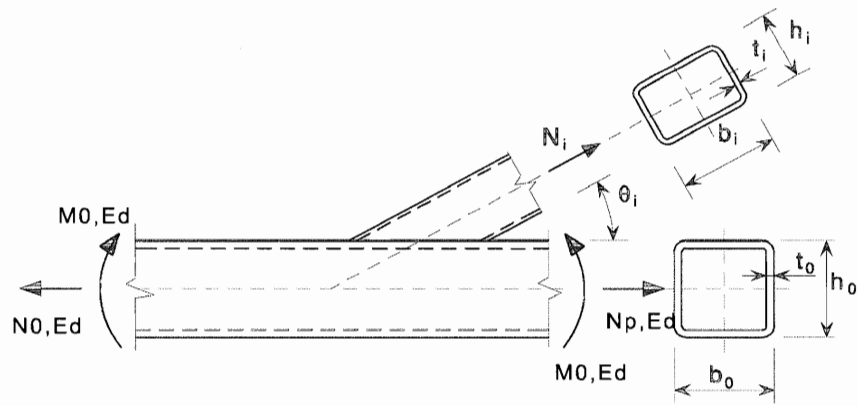
η_p is the ratio h_i/b_p ;

λ_{ov} is the overlap ratio, expressed as a percentage ($\lambda_{ov} = (q/p) \times 100\%$) as shown in figure 1.3(b);

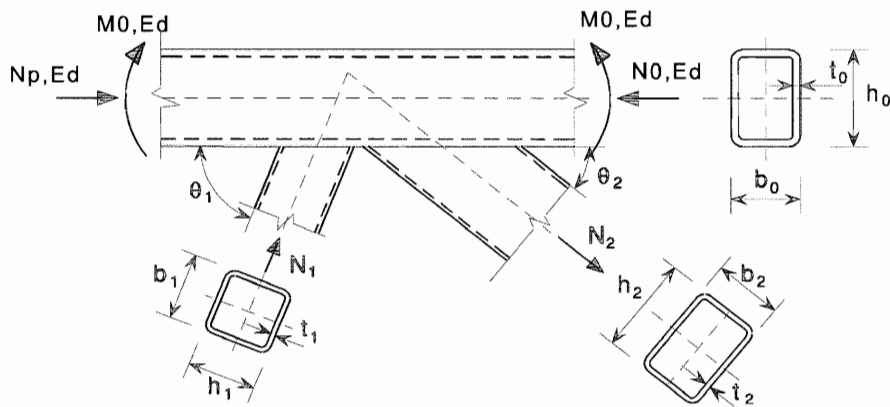
AC2 $\lambda_{ov,lim}$ is the overlap for which shear between braces and chord face may become critical. **AC2**

(7) Other symbols are specified in appropriate clauses when they are used.

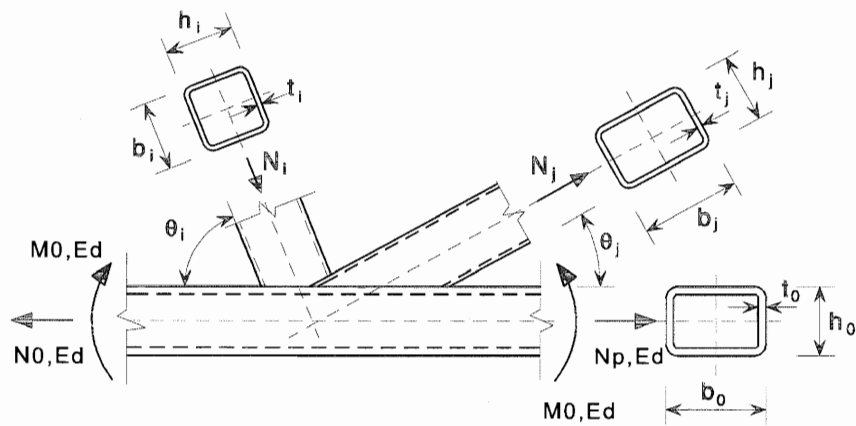
NOTE: Symbols for circular sections are given in Table 7.2.



a) Joint with single brace member



b) Gap joint with two brace members



c) Overlap joint with two brace members

Figure 1.4: Dimensions and other parameters at a hollow section lattice girder joint

2 Basis of design

2.1 Assumptions

- (1) The design methods given in this part of EN 1993 assume that the standard of construction is as specified in the execution standards given in 1.2 and that the construction materials and products used are those specified in EN 1993 or in the relevant material and product specifications.

2.2 General requirements

- AC1** (1)P All joints shall have a design resistance such that the structure is capable of satisfying all the basic design requirements given in this Standard and in EN 1993-1-1. **AC1**
- (2) The partial safety factors γ_M for joints are given in Table 2.1.

Table 2.1: Partial safety factors for joints

Resistance of members and cross-sections	γ_{M0} , γ_{M1} and γ_{M2} see EN 1993-1-1
Resistance of bolts	γ_{M2}
Resistance of rivets	
Resistance of pins	
Resistance of welds	
Resistance of plates in bearing	
Slip resistance - at ultimate limit state (Category C) - at serviceability limit state (Category B)	γ_{M3} $\gamma_{M3,ser}$
Bearing resistance of an injection bolt	γ_{M4}
Resistance of joints in hollow section lattice girder	γ_{M5}
Resistance of pins at serviceability limit state	$\gamma_{M6,ser}$
Preload of high strength bolts	γ_{M7}
Resistance of concrete	γ_c see EN 1992

NOTE: Numerical values for γ_M may be defined in the National Annex. Recommended values are as follows: $\gamma_{M2} = 1,25$; $\gamma_{M3} = 1,25$ and $\gamma_{M3,ser} = 1,1$; $\gamma_{M4} = 1,0$; $\gamma_{M5} = 1,0$; $\gamma_{M6,ser} = 1,0$; $\gamma_{M7} = 1,1$.

- AC1** (3)P Joints subject to fatigue shall also satisfy the principles given in EN 1993-1-9. **AC1**

2.3 Applied forces and moments

- AC1** (1)P The forces and moments applied to joints at the ultimate limit state shall be determined according to the principles in EN 1993-1-1. **AC1**

2.4 Resistance of joints

- (1) The resistance of a joint should be determined on the basis of the resistances of its basic components.
- (2) Linear-elastic or elastic-plastic analysis may be used in the design of joints.

- (3) Where fasteners with different stiffnesses are used to carry a shear load the fasteners with the highest stiffness should be designed to carry the design load. An exception to this design method is given in 3.9.3.

2.5 Design assumptions

- AC1** (1)P Joints shall be designed on the basis of a realistic assumption of the distribution of internal forces and moments. The following assumptions shall be used to determine the distribution of forces:
- (a) the internal forces and moments assumed in the analysis are in equilibrium with the forces and moments applied to the joints,
 - (b) each element in the joint is capable of resisting the internal forces and moments,
 - (c) the deformations implied by this distribution do not exceed the deformation capacity of the fasteners or welds and the connected parts,
 - (d) the assumed distribution of internal forces shall be realistic with regard to relative stiffnesses within the joint,
 - (e) the deformations assumed in any design model based on elastic-plastic analysis are based on rigid body rotations and/or in-plane deformations which are physically possible, and
 - (f) any model used is in compliance with the evaluation of test results (see EN 1990). **AC1**
- (2) The application rules given in this part satisfy 2.5(1).

2.6 Joints loaded in shear subject to impact, vibration and/or load reversal

- (1) Where a joint loaded in shear is subject to impact or significant vibration one of the following jointing methods should be used:
- welding
 - bolts with locking devices
 - preloaded bolts
 - injection bolts
 - other types of bolt which effectively prevent movement of the connected parts
 - rivets.
- (2) Where slip is not acceptable in a joint (because it is subject to reversal of shear load or for any other reason), preloaded bolts in a Category B or C connection (see 3.4), fit bolts (see 3.6.1), rivets or welding should be used.
- (3) For wind and/or stability bracings, bolts in Category A connections (see 3.4) may be used.

2.7 Eccentricity at intersections

- (1) Where there is eccentricity at intersections, the joints and members should be designed for the resulting moments and forces, except in the case of particular types of structures where it has been demonstrated that it is not necessary, see 5.1.5.
- (2) In the case of joints of angles or tees attached by either a single line of bolts or two lines of bolts any possible eccentricity should be taken into account in accordance with 2.7(1). In-plane and out-of-plane eccentricities should be determined by considering the relative positions of the centroidal axis of the member and of the setting out line in the plane of the connection (see Figure 2.1). For a single angle in tension connected by bolts on one leg the simplified design method given in 3.10.3 may be used.

NOTE: The effect of eccentricity on angles used as web members in compression is given in EN 1993-1-1, Annex BB 1.2.

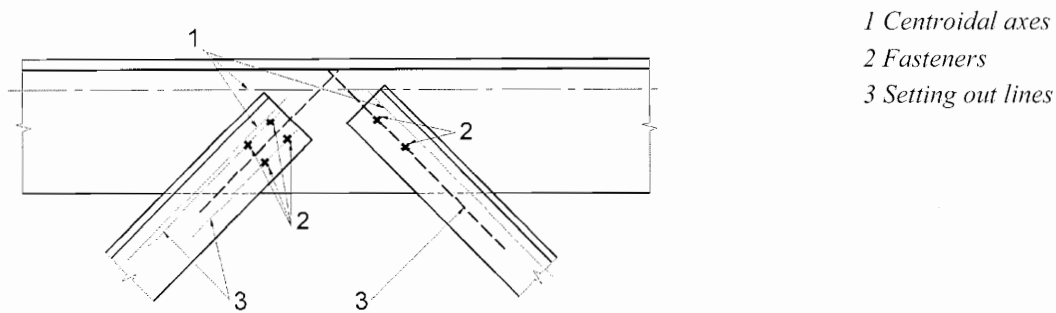


Figure 2.1: Setting out lines

3 Connections made with bolts, rivets or pins

3.1 Bolts, nuts and washers

3.1.1 General

- (1) All bolts, nuts and washers should comply with 1.2.4 Reference Standards: Group 4.
- (2) The rules in this Standard are valid for the bolt classes given in Table 3.1.
- (3) The yield strength f_{yb} and the ultimate tensile strength f_{ub} for bolt classes 4.6, 4.8, 5.6, 5.8, 6.8, 8.8 and 10.9 are given in Table 3.1. These values should be adopted as characteristic values in design calculations.

Table 3.1: Nominal values of the yield strength f_{yb} and the ultimate tensile strength f_{ub} for bolts

Bolt class	4.6	4.8	5.6	5.8	6.8	8.8	10.9
f_{yb} (N/mm ²)	240	320	300	400	480	640	900
f_{ub} (N/mm ²)	400	400	500	500	600	800	1000

NOTE: The National Annex may exclude certain bolt classes.

3.1.2 Preloaded bolts

- (1) Only bolt assemblies of classes 8.8 and 10.9 conforming to the requirements given in 1.2.4 Reference Standards: Group 4 for High Strength Structural Bolting for preloading with controlled tightening in accordance with the requirements in 1.2.7 Reference Standards: Group 7 may be used as preloaded bolts.

3.2 Rivets

- (1) The material properties, dimensions and tolerances of steel rivets should comply with the requirements given in 1.2.6 Reference Standards: Group 6.

3.3 Anchor bolts

- (1) The following materials may be used for anchor bolts:
- Steel grades conforming to 1.2.1 Reference Standards: Group 1;
 - Steel grades conforming to 1.2.4 Reference Standards: Group 4;
 - Steel grades used for reinforcing bars conforming to EN 10080;

provided that the nominal yield strength does not exceed 640 N/mm^2 when the anchor bolts are required to act in shear and not more than 900 N/mm^2 otherwise.

3.4 Categories of bolted connections

3.4.1 Shear connections

- (1) Bolted connections loaded in shear should be designed as one of the following:

a) **Category A: Bearing type**

In this category bolts from class 4.6 up to and including class 10.9 should be used. No preloading and special provisions for contact surfaces are required. The design ultimate shear load should not exceed the design shear resistance, obtained from 3.6, nor the design bearing resistance, obtained from 3.6 and 3.7.

b) **Category B: Slip-resistant at serviceability limit state**

In this category preloaded bolts in accordance with 3.1.2(1) should be used. Slip should not occur at the serviceability limit state. The design serviceability shear load should not exceed the design slip resistance, obtained from 3.9. The design ultimate shear load should not exceed the design shear resistance, obtained from 3.6, nor the design bearing resistance, obtained from 3.6 and 3.7.

c) **Category C: Slip-resistant at ultimate limit state**

In this category preloaded bolts in accordance with 3.1.2(1) should be used. Slip should not occur at the ultimate limit state. The design ultimate shear load should not exceed the design slip resistance, obtained from 3.9, nor the design bearing resistance, obtained from 3.6 and 3.7. In addition for a connection in tension, the design plastic resistance of the net cross-section at bolt holes $N_{\text{net,Rd}}$ (see 6.2 of EN 1993-1-1), should be checked, at the ultimate limit state.

The design checks for these connections are summarized in Table 3.2.

3.4.2 Tension connections

- (1) Bolted connection loaded in tension should be designed as one of the following:

a) **Category D: non-preloaded**

In this category bolts from class 4.6 up to and including class 10.9 should be used. No preloading is required. This category should not be used where the connections are frequently subjected to variations of tensile loading. However, they may be used in connections designed to resist normal wind loads.

b) **Category E: preloaded**

In this category preloaded 8.8 and 10.9 bolts with controlled tightening in conformity with 1.2.7 Reference Standards: Group 7 should be used.

The design checks for these connections are summarized in Table 3.2.

Table 3.2: Categories of bolted connections

Category	Criteria	Remarks
Shear connections		
A bearing type	$F_{v,Ed} \leq F_{v,Rd}$ $F_{v,Ed} \leq F_{b,Rd}$	No preloading required. Bolt classes from 4.6 to 10.9 may be used.
B slip-resistant at serviceability	$F_{v,Ed,ser} \leq F_{s,Rd,ser}$ $F_{v,Ed} \leq F_{v,Rd}$ $F_{v,Ed} \leq F_{b,Rd}$	Preloaded 8.8 or 10.9 bolts should be used. For slip resistance at serviceability see 3.9.
C slip-resistant at ultimate	$F_{v,Ed} \leq F_{s,Rd}$ $F_{v,Ed} \leq F_{b,Rd}$ $\langle AC2 \rangle \sum F_{v,Ed} \leq N_{net,Rd} \langle AC2 \rangle$	Preloaded 8.8 or 10.9 bolts should be used. For slip resistance at ultimate see 3.9. $N_{net,Rd}$ see 3.4.1(1) c).
Tension connections		
D non-preloaded	$F_{t,Ed} \leq F_{t,Rd}$ $F_{t,Ed} \leq B_{p,Rd}$	No preloading required. Bolt classes from 4.6 to 10.9 may be used. $B_{p,Rd}$ see Table 3.4.
E preloaded	$F_{t,Ed} \leq F_{t,Rd}$ $F_{t,Ed} \leq B_{p,Rd}$	Preloaded 8.8 or 10.9 bolts should be used. $B_{p,Rd}$ see Table 3.4.
The design tensile force $F_{t,Ed}$ should include any force due to prying action, see 3.11. Bolts subjected to both shear force and tensile force should also satisfy the criteria given in Table 3.4.		

NOTE: If preload is not explicitly used in the design calculations for slip resistances but is required for execution purposes or as a quality measure (e.g. for durability) then the level of preload can be specified in the National Annex.

3.5 Positioning of holes for bolts and rivets

- (1) Minimum and maximum spacing and end and edge distances for bolts and rivets are given in Table 3.3.
- (2) Minimum and maximum spacing, end and edge distances for structures subjected to fatigue, see EN 1993-1-9.

Table 3.3: Minimum and maximum spacing, end and edge distances

Distances and spacings, see Figure 3.1	Minimum	Maximum ^{1) 2) 3)}		
		Structures made from steels conforming to EN 10025 except steels conforming to EN 10025-5		Structures made from steels conforming to EN 10025-5
		Steel exposed to the weather or other corrosive influences	Steel not exposed to the weather or other corrosive influences	Steel used unprotected
End distance e_1	$1,2d_0$	$4t + 40$ mm		The larger of $8t$ or 125 mm
Edge distance e_2	$1,2d_0$	$4t + 40$ mm		The larger of $8t$ or 125 mm
Distance e_3 in slotted holes	$1,5d_0$ ⁴⁾			
Distance e_4 in slotted holes	$1,5d_0$ ⁴⁾			
Spacing p_1	$2,2d_0$	The smaller of $14t$ or 200 mm	The smaller of $14t$ or 200 mm	The smaller of $14t_{\min}$ or 175 mm
Spacing $p_{1,0}$		The smaller of $14t$ or 200 mm		
Spacing $p_{1,i}$		The smaller of $28t$ or 400 mm		
Spacing p_2 ⁵⁾	$2,4d_0$	The smaller of $14t$ or 200 mm	The smaller of $14t$ or 200 mm	The smaller of $14t_{\min}$ or 175 mm

¹⁾ Maximum values for spacings, edge and end distances are unlimited, except in the following cases:

- for compression members in order to avoid local buckling and to prevent corrosion in $\overline{AC_2}$ exposed members (the limiting values are given in the table) and; $\overline{AC_2}$
- for exposed tension members $\overline{AC_2}$ to prevent corrosion (the limiting values are given in the table). $\overline{AC_2}$

²⁾ The local buckling resistance of the plate in compression between the fasteners should be calculated according to EN 1993-1-1 using $0,6 p_1$ as buckling length. Local buckling between the fasteners need not to be checked if p_1/t is smaller than 9ε . The edge distance should not exceed the local buckling requirements for an outstand element in the compression members, see EN 1993-1-1. The end distance is not affected by this requirement.

³⁾ t is the thickness of the thinner outer connected part.

⁴⁾ The dimensional limits for slotted holes are given in 1.2.7 Reference Standards: Group 7.

⁵⁾ For staggered rows of fasteners a minimum line spacing of $p_2 = 1,2d_0$ may be used, provided that the minimum distance, L , between any two fasteners is greater or equal than $2,4d_0$, see Figure 3.1b).

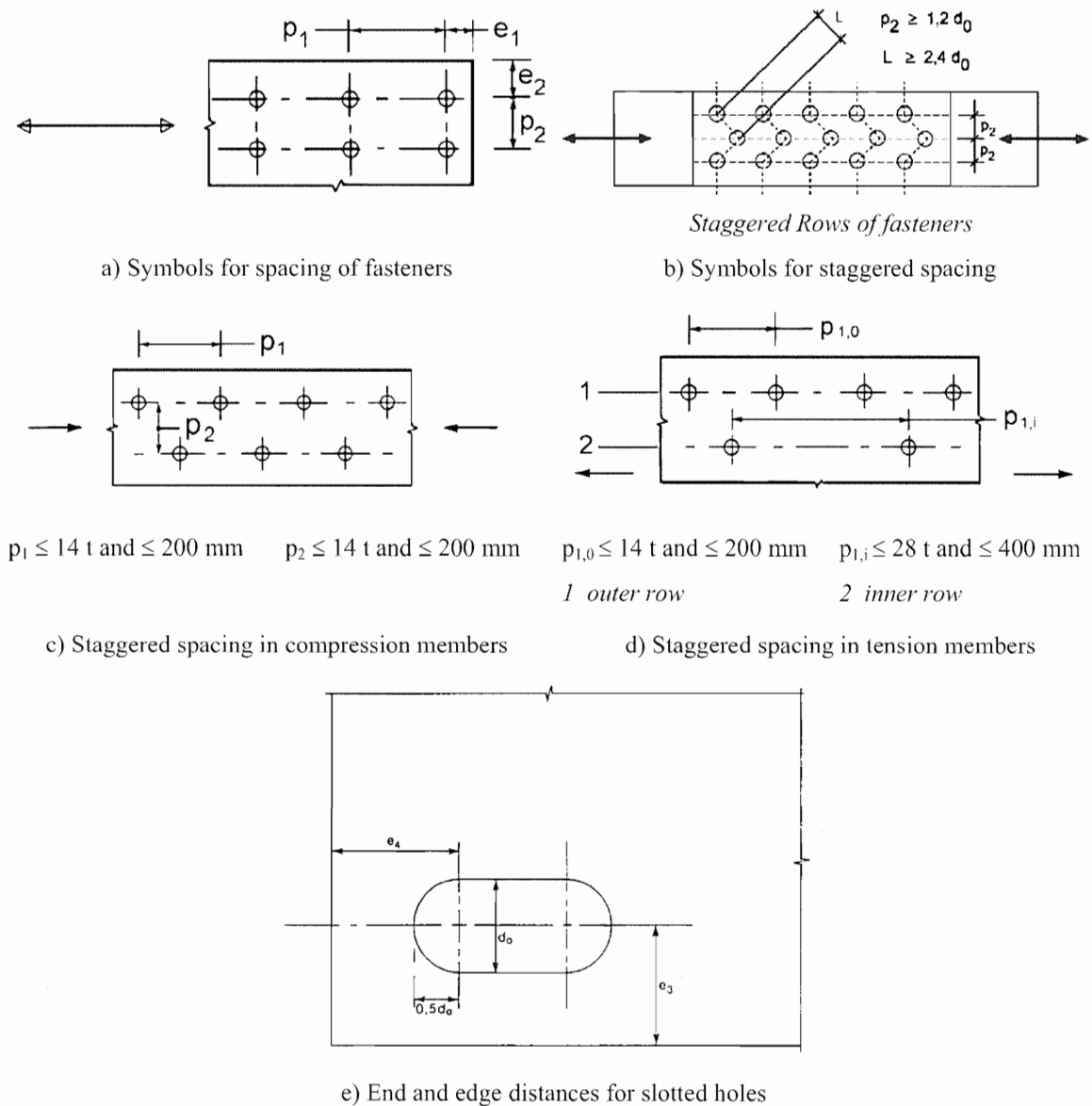


Figure 3.1: Symbols for end and edge distances and spacing of fasteners

3.6 Design resistance of individual fasteners

3.6.1 Bolts and rivets

- (1) The design resistance for an individual fastener subjected to shear and/or tension is given in Table 3.4.
- (2) For preloaded bolts in accordance with 3.1.2(1) the design preload, $F_{p,Cd}$, to be used in design calculations should be taken as:

$$F_{p,Cd} = 0,7 f_{ub} A_s / \gamma_{M7} \quad \dots (3.1)$$

NOTE: Where the preload is not used in design calculations see note to Table 3.2.

- (3) The design resistances for tension and for shear through the threaded portion of a bolt given in Table 3.4 should only be used for bolts manufactured in conformity with 1.2.4 Reference Standard: Group 4.

For bolts with cut threads, such as anchor bolts or tie rods fabricated from round steel bars where the threads comply with EN 1090, the relevant values from Table 3.4 should be used. For bolts with cut threads where the threads do not comply with EN 1090 the relevant values from Table 3.4 should be multiplied by a factor of 0,85.

- (4) The design shear resistance $F_{v,Rd}$ given in Table 3.4 should only be used where the bolts are used in holes with nominal clearances not exceeding those for normal holes as specified in 1.2.7 Reference Standards: Group 7.
- (5) M12 and M14 bolts may also be used in 2 mm clearance holes provided that the design resistance of the bolt group based on bearing $\overline{AC2}$ is less than or equal to $\overline{AC2}$ the design resistance of the bolt group based on bolt shear. In addition for class 4.8, 5.8, 6.8, 8.8 and 10.9 bolts the design shear resistance $F_{v,Rd}$ should be taken as 0,85 times the value given in Table 3.4.
- (6) Fit bolts should be designed using the method for bolts in normal holes.
- (7) The thread of a fit bolt should not be included in the shear plane.
- (8) The length of the threaded portion of a fit bolt included in the bearing length should not exceed 1/3 of the thickness of the plate, see Figure 3.2.
- (9) The hole tolerance used for fit bolts should be in accordance with 1.2.7 Reference Standards: Group 7.
- (10) In single lap joints with only one bolt row, see Figure 3.3, the bolts should be provided with washers under both the head and the nut. The design bearing resistance $F_{b,Rd}$ for each bolt should be limited to:

$$F_{b,Rd} \leq 1,5 f_u d t / \gamma_{M2} \quad \dots (3.2)$$

NOTE: Single rivets should not be used in single lap joints.

- (11) In the case of class 8.8 or 10.9 bolts, hardened washers should be used for single lap joints with only one bolt or one row of bolts.
- (12) Where bolts or rivets transmitting load in shear and bearing pass through packing of total thickness t_p greater than one-third of the nominal diameter d , see Figure 3.4, the design shear resistance $F_{v,Rd}$ calculated as specified in Table 3.4, should be multiplying by a reduction factor β_p given by:

$$\beta_p = \frac{9d}{8d + 3t_p} \quad \text{but } \beta_p \leq 1 \quad \dots (3.3)$$

- (13) For double shear connections with packing on both sides of the splice, t_p should be taken as the thickness of the thicker packing.
- (14) Riveted connections should be designed to transfer shear forces. If tension is present the design tensile force $F_{t,Ed}$ should not exceed the design tension resistance $F_{t,Rd}$ given in Table 3.4.
- (15) For grade S 235 steel the "as driven" value of f_{ur} may be taken as 400 N/mm².
- (16) As a general rule, the grip length of a rivet should not exceed 4,5d for hammer riveting and 6,5d for press riveting.

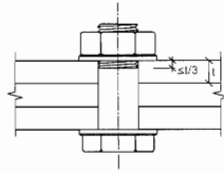


Figure 3.2: Threaded portion of the shank in the bearing length for fit bolts

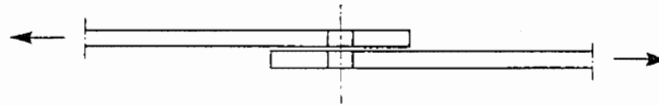


Figure 3.3: Single lap joint with one row of bolts

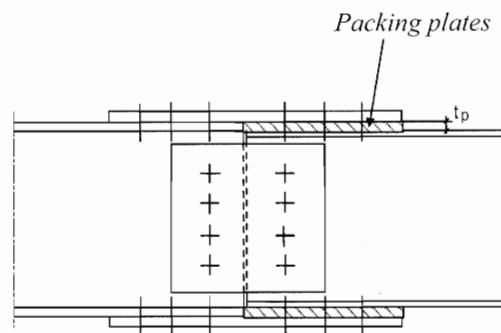


Figure 3.4: Fasteners through packings

Table 3.4: Design resistance for individual fasteners subjected to shear and/or tension

Failure mode	Bolts	Rivets
Shear resistance per shear plane	$F_{v,Rd} = \frac{\alpha_v f_{ub} A}{\gamma_{M2}}$ <p>- where the shear plane passes through the threaded portion of the bolt (A is the tensile stress area of the bolt A_s):</p> <ul style="list-style-type: none"> - for classes 4.6, 5.6 and 8.8: $\alpha_v = 0,6$ - for classes 4.8, 5.8, 6.8 and 10.9: $\alpha_v = 0,5$ <p>- where the shear plane passes through the unthreaded portion of the bolt (A is the gross cross section of the bolt): $\alpha_v = 0,6$</p>	$F_{v,Rd} = \frac{0,6 f_{ur} A_0}{\gamma_{M2}}$
Bearing resistance ^{1), 2), 3)}	$\boxed{\text{AC2}} F_{b,Rd} = \frac{k_1 \alpha_b f_u d t}{\gamma_{M2}} \boxed{\text{AC2}}$ <p>where α_b is the smallest of α_d; $\frac{f_{ub}}{f_u}$ or 1,0;</p> <p>in the direction of load transfer:</p> <ul style="list-style-type: none"> - for end bolts: $\alpha_d = \frac{e_1}{3d_0}$; for inner bolts: $\alpha_d = \frac{p_1}{3d_0} - \frac{1}{4}$ <p>perpendicular to the direction of load transfer:</p> <ul style="list-style-type: none"> $\boxed{\text{AC2}}$- for edge bolts: k_1 is the smallest of $2,8 \frac{e_2}{d_0} - 1,7$, $1,4 \frac{p_2}{d_0} - 1,7$ and $2,5 \boxed{\text{AC2}}$ - for inner bolts: k_1 is the smallest of $1,4 \frac{p_2}{d_0} - 1,7$ or 2,5 	
Tension resistance ²⁾	$F_{t,Rd} = \frac{k_2 f_{ub} A_s}{\gamma_{M2}}$ <p>where $k_2 = 0,63$ for countersunk bolt, otherwise $k_2 = 0,9$.</p>	$F_{t,Rd} = \frac{0,6 f_{ur} A_0}{\gamma_{M2}}$
Punching shear resistance	$B_{p,Rd} = 0,6 \pi d_m t_p f_u / \gamma_{M2}$	No check needed
Combined shear and tension	$\frac{F_{v,Ed}}{F_{v,Rd}} + \frac{F_{t,Ed}}{1,4 F_{t,Rd}} \leq 1,0$	
<p>¹⁾ The bearing resistance $F_{b,Rd}$ for bolts</p> <ul style="list-style-type: none"> - in oversized holes is 0,8 times the bearing resistance for bolts in normal holes. - in slotted holes, where the longitudinal axis of the slotted hole is perpendicular to the direction of the force transfer, is 0,6 times the bearing resistance for bolts in round, normal holes. <p>²⁾ For countersunk bolt:</p> <ul style="list-style-type: none"> - the bearing resistance $F_{b,Rd}$ should be based on a plate thickness t equal to the thickness of the connected plate minus half the depth of the countersinking. - for the determination of the tension resistance $F_{t,Rd}$ the angle and depth of countersinking should conform with 1.2.4 Reference Standards: Group 4, otherwise the tension resistance $F_{t,Rd}$ should be adjusted accordingly. <p>³⁾ When the load on a bolt is not parallel to the edge, the bearing resistance may be verified separately for the bolt load components parallel and normal to the end.</p>		

3.6.2 Injection bolts

3.6.2.1 General

- (1) Injection bolts may be used as an alternative to ordinary bolts and rivets for category A, B and C connections specified in 3.4.
- (2) Fabrication and erection details for injection bolts are given in 1.2.7 Reference Standards: Group 7.

3.6.2.2 Design resistance

- (1) The design method given in 3.6.2.2(2) to 3.6.2.2(6) should be used for connections with injection bolts of class 8.8 or 10.9. Bolt assemblies should conform with the requirements given in 1.2.4 Reference Standards: Group 4, but see 3.6.2.2(3) for when preloaded bolts are used.
- (2) The design ultimate shear load of any bolt in a Category A connection should not exceed the smaller of the following: the design shear resistance $\overline{AC_2}$ of the bolt or a group of bolts as obtained $\overline{AC_2}$ from 3.6 and 3.7; the design bearing resistance of the resin as obtained from 3.6.2.2(5).
- (3) Preloaded injection bolts should be used for category B and C connections, for which preloaded bolt assemblies in accordance with 3.1.2(1) should be used.
- (4) The design serviceability shear load of any bolt in a category B connection and the design ultimate shear load of any bolt in a category C connection should not exceed the design slip resistance of the bolt as obtained from 3.9 at the relevant limit state plus the design bearing resistance of the resin as obtained from 3.6.2.2(5) at the relevant limit state. In addition the design ultimate shear load of a bolt in a category B or C connection should not exceed either the design shear resistance of the bolt as obtained from 3.6, nor the design bearing resistance of the bolt as obtained from 3.6 and 3.7.
- (5) The design bearing resistance of the resin, $F_{b,Rd,resin}$, may be determined according to the following equation:

$$F_{b,Rd,resin} = \frac{k_t k_s d t_{b,resin} \beta f_{b,resin}}{\gamma_{M4}} \quad \dots (3.4)$$

where:

$F_{b,Rd,resin}$ is the bearing strength of an injection bolt

β is a coefficient depending of the thickness ratio of the connected plates as given in Table 3.5 and Figure 3.5

$f_{b,resin}$ is the bearing strength of the resin to be determined according to the 1.2.7 Reference Standards: Group 7.

$t_{b,resin}$ is the effective bearing thickness of the resin, given in Table 3.5

k_t is 1,0 for serviceability limit state (long duration)
is 1,2 for ultimate limit state

k_s is taken as 1,0 for holes with normal clearances or (1,0 - 0,1 m), for oversized holes

m is the difference (in mm) between the normal and oversized hole dimensions. In the case of short slotted holes as specified in 1.2.7 Reference Standards: Group 7, $m = 0,5 \cdot$ (the difference (in mm) between the hole length and width).

- (6) When calculating the bearing resistance of a bolt with a clamping length exceeding $3d$, a value of not more than $3d$ should be taken to determine the effective bearing thickness $t_{b,resin}$ (see Figure 3.6).

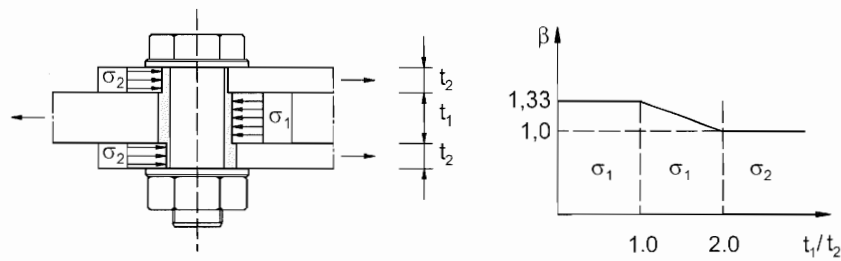


Figure 3.5: Factor β as a function of the thickness ratio of the connected plates

Table 3.5: Values of β and $t_{b,resin}$

t_1 / t_2	β	$t_{b,resin}$
$\geq 2,0$	1,0	$2 t_2 \leq 1,5 d$
$1,0 < t_1 / t_2 < 2,0$	$1,66 - 0,33 (t_1 / t_2)$	$t_1 \leq 1,5 d$
$\leq 1,0$	1,33	$t_1 \leq 1,5 d$

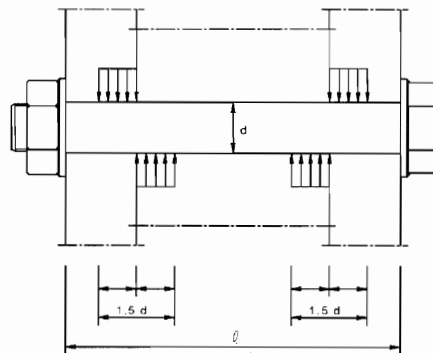


Figure 3.6: Limiting effective length for long injection bolts

3.7 Group of fasteners

- (1) The design resistance of a group of fasteners may be taken as the sum of the design bearing resistances $F_{b,Rd}$ of the individual fasteners provided that the design shear resistance $F_{v,Rd}$ of each individual fastener is greater than or equal to the design bearing resistance $F_{b,Rd}$. Otherwise the design resistance of a group of fasteners should be taken as the number of fasteners multiplied by the smallest design resistance of any of the individual fasteners.

3.8 Long joints

- (1) Where the distance L_j between the centres of the end fasteners in a joint, measured in the direction of force transfer (see Figure 3.7), is more than $15 d$, the design shear resistance $F_{v,Rd}$ of all the fasteners calculated according to Table 3.4 should be reduced by multiplying it by a reduction factor β_{Lf} , given by:

$$\beta_{Lf} = 1 - \frac{L_j - 15d}{200d} \quad \dots (3.5)$$

but $\beta_{Lf} \leq 1,0$ and $\beta_{Lf} \geq 0,75$

- (2) The provision in 3.8(1) does not apply where there is a uniform distribution of force transfer over the length of the joint, e.g. the transfer of shear force between the web and the flange of a section.

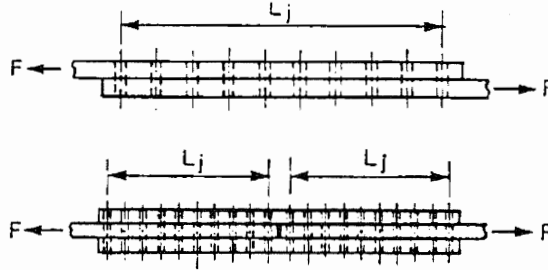


Figure 3.7: Long joints

3.9 Slip-resistant connections using 8.8 or 10.9 bolts

3.9.1 Design Slip resistance

- (1) The design slip resistance of a preloaded class 8.8 or 10.9 bolt should be taken as:

$$F_{s,Rd} = \frac{k_s n \mu}{\gamma_{M3}} F_{p,C} \quad \text{AC2} \dots (3.6a) \text{AC2}$$

$$\text{AC2} F_{s,Rd,ser} = \frac{k_s n \mu}{\gamma_{M3,scr}} F_{p,C} \quad \dots (3.6b) \text{AC2}$$

where:

k_s is given in Table 3.6

n is the number of AC2 the friction planes AC2

μ is the slip factor obtained either by specific tests for the friction surface in accordance with 1.2.7 Reference Standards: Group 7 or when relevant as given in Table 3.7.

- (2) For class 8.8 and 10.9 bolts conforming with 1.2.4 Reference Standards: Group 4, with controlled tightening in conformity with 1.2.7 Reference Standards: Group 7, the preloading force $F_{p,C}$ to be used in equation (3.6) should be taken as:

$$F_{p,C} = 0,7 f_{ub} A_s \quad \dots (3.7)$$

Table 3.6: Values of k_s

Description	k_s
Bolts in normal holes.	1,0
Bolts in either oversized holes or short slotted holes with the axis of the slot perpendicular to the direction of load transfer.	0,85
Bolts in long slotted holes with the axis of the slot perpendicular to the direction of load transfer.	0,7
Bolts in short slotted holes with the axis of the slot parallel to the direction of load transfer.	0,76
Bolts in long slotted holes with the axis of the slot parallel to the direction of load transfer.	0,63

Table 3.7: Slip factor, μ , for pre-loaded bolts

Class of friction surfaces (see 1.2.7 Reference Standard: Group 7)	Slip factor μ
A	0,5
B	0,4
C	0,3
D	0,2

NOTE 1: The requirements for testing and inspection are given in 1.2.7 Reference Standards: Group 7.

NOTE 2: The classification of any other surface treatment should be based on test specimens representative of the surfaces used in the structure using the procedure set out in 1.2.7 Reference Standards: Group 7.

NOTE 3: The definitions of the class of friction surface are given in 1.2.7 Reference Standards: Group 7.

NOTE 4: With painted surface treatments a loss of pre-load may occur over time.

3.9.2 Combined tension and shear

- (1) If a slip-resistant connection is subjected to an applied tensile force, $F_{t,Ed}$ or $F_{t,Ed,ser}$, in addition to the shear force, $F_{v,Ed}$ or $F_{v,Ed,ser}$, tending to produce slip, the design slip resistance per bolt should be taken as follows:

for a category B connection:
$$F_{s,Rd,ser} = \frac{k_s n \mu (F_{p,C} - 0,8 F_{t,Ed,ser})}{\gamma_{M3,ser}} \quad \dots (3.8a)$$

for a category C connection:
$$F_{s,Rd} = \frac{k_s n \mu (F_{p,C} - 0,8 F_{t,Ed})}{\gamma_{M3}} \quad \dots (3.8b)$$

- (2) If, in a moment connection, a contact force on the compression side counterbalances the applied tensile force no reduction in slip resistance is required.

3.9.3 Hybrid connections

- (1) As an exception to 2.4(3), preloaded class 8.8 and 10.9 bolts in connections designed as slip-resistant at the ultimate limit state (Category C in 3.4) may be assumed to share load with welds, provided that the final tightening of the bolts is carried out after the welding is complete.

3.10 Deductions for fastener holes

3.10.1 General

- (1) Deduction for holes in the member design should be made according to EN 1993-1-1.

3.10.2 Design for block tearing

(1) Block tearing consists of failure in shear at the row of bolts along the shear face of the hole group accompanied by tensile rupture along the line of bolt holes on the tension face of the bolt group. Figure 3.8 shows block tearing.

(2) For a symmetric bolt group subject to concentric loading the design block tearing resistance, $V_{eff,1,Rd}$ is given by:

$$V_{eff,1,Rd} = f_u A_{nt} / \gamma_{M2} + (1 / \sqrt{3}) f_y A_{nv} / \gamma_{M0} \quad \dots (3.9)$$

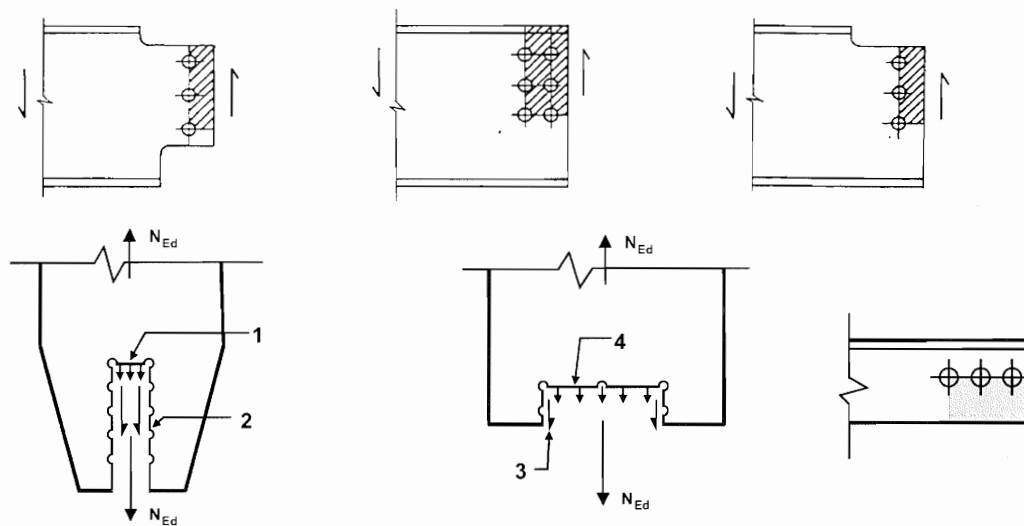
where:

A_{nt} is net area subjected to tension;

A_{nv} is net area subjected to shear.

(3) For a bolt group subject to eccentric loading the design block shear tearing resistance $V_{eff,2,Rd}$ is given by:

$$V_{eff,2,Rd} = 0,5 f_u A_{nt} / \gamma_{M2} + (1 / \sqrt{3}) f_y A_{nv} / \gamma_{M0} \quad \dots (3.10)$$



- 1 small tension force
- 2 large shear force
- 3 small shear force
- 4 large tension force

Figure 3.8: Block tearing

3.10.3 Angles connected by one leg and other unsymmetrically connected members in tension

- (1) The eccentricity in joints, see 2.7(1), and the effects of the spacing and edge distances of the bolts, should be taken into account in determining the design resistance of:
- unsymmetrical members;
 - symmetrical members that are connected unsymmetrically, such as angles connected by one leg.
- (2) A single angle in tension connected by a single row of bolts in one leg, see Figure 3.9, may be treated as concentrically loaded over an effective net section for which the design ultimate resistance should be determined as follows:

with 1 bolt:
$$N_{u,Rd} = \frac{2,0(e_2 - 0,5d_0)t f_u}{\gamma_{M2}} \quad \dots (3.11)$$

with 2 bolts:
$$N_{u,Rd} = \frac{\beta_2 A_{net} f_u}{\gamma_{M2}} \quad \dots (3.12)$$

with 3 or more bolts:
$$N_{u,Rd} = \frac{\beta_3 A_{net} f_u}{\gamma_{M2}} \quad \dots (3.13)$$

where:

β_2 and β_3 are reduction factors dependent on the pitch p_1 as given in Table 3.8. For intermediate values of p_1 the value of β may be determined by linear interpolation;

A_{net} is the net area of the angle. For an unequal-leg angle connected by its smaller leg, A_{net} should be taken as equal to the net section area of an equivalent equal-leg angle of leg size equal to that of the smaller leg.

Table 3.8: Reduction factors β_2 and β_3

Pitch	p_1	$\leq 2,5 d_0$	$\geq 5,0 d_0$
2 bolts	β_2	0,4	0,7
3 bolts or more	β_3	0,5	0,7

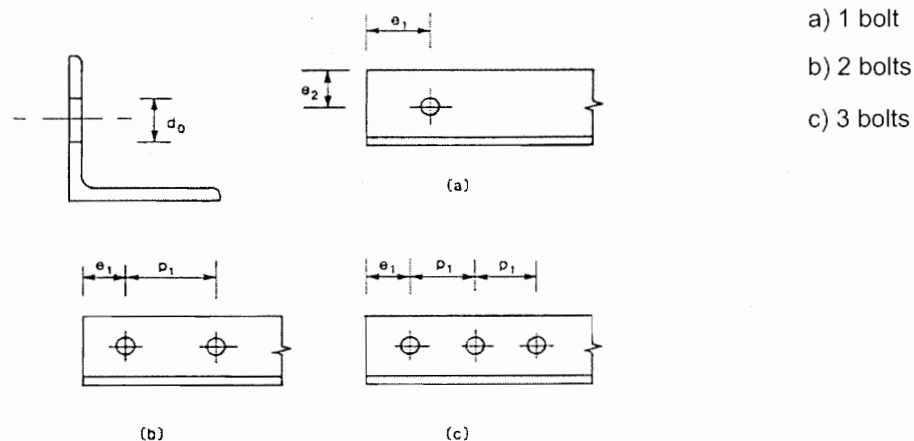


Figure 3.9: Angles connected by one leg

3.10.4 Lug angles

- (1) The Lug angle shown in Figure 3.10 connects angle members and their fasteners to a gusset or other supporting part and should be designed to transmit a force 1,2 times the force in the outstand of the angle connected.
- (2) The fasteners connecting the lug angle to the outstand of the angle member should be designed to transmit a force 1,4 times the force in the outstand of the angle member.
- (3) Lug angles connecting a channel or a similar member should be designed to transmit a force 1,1 times the force in the channel flanges to which they are attached.
- (4) The fasteners connecting the lug angle to the channel or similar member should be designed to transmit a force 1,2 times the force in the channel flange which they connect.
- (5) In no case should less than two bolts or rivets be used to attach a lug angle to a gusset or other supporting part.
- (6) The connection of a lug angle to a gusset plate or other supporting part should terminate at the end of the member connected. The connection of the lug angle to the member should run from the end of the member to a point beyond the direct connection of the member to the gusset or other supporting part.

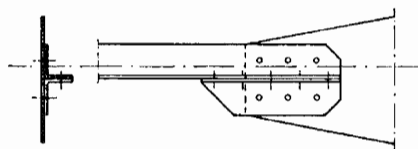


Figure 3.10: Lug angles

3.11 Prying forces

- (1) Where fasteners are required to carry an applied tensile force, they should be designed to resist the additional force due to prying action, where this can occur.

NOTE: The rules given in 6.2.4 implicitly account for prying forces.

3.12 Distribution of forces between fasteners at the ultimate limit state

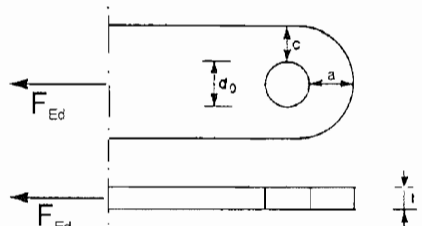
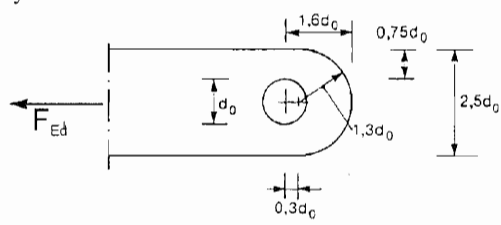
- (1) When a moment is applied to a joint, the distribution of internal forces may be either linear (i.e. proportional to the distance from the centre of rotation) or plastic, (i.e. any distribution that is in equilibrium is acceptable provided that the resistances of the components are not exceeded and the ductility of the components is sufficient).
- (2) The elastic linear distribution of internal forces should be used for the following:
 - when bolts are used creating a category C slip-resistant connection,
 - in shear connections where the design shear resistance $F_{v,Rd}$ of a fastener is less than the design bearing resistance $F_{b,Rd}$,
 - where connections are subjected to impact, vibration or load reversal (except wind loads).
- (3) When a joint is loaded by a concentric shear only, the load may be assumed to be uniformly distributed amongst the fasteners, provided that the size and the class of fasteners is the same.

3.13 Connections made with pins

3.13.1 General

- (1) Wherever there is a risk of pins becoming loose, they should be secured.
- (2) Pin connections in which no rotation is required may be designed as single bolted connections, provided that the length of the pin is less than 3 times the diameter of the pin, see 3.6.1. For all other cases the method given in 3.13.2 should be followed.
- (3) In pin-connected members the geometry of the unstiffened element that contains a hole for the pin should satisfy the dimensional requirements given in Table 3.9.

Table 3.9: Geometrical requirements for pin ended members

<p>Type A:</p>	<p>Given thickness t</p>  $a \geq \frac{F_{Ed} \gamma_{M0}}{2 t f_y} + \frac{2 d_0}{3} : c \geq \frac{F_{Ed} \gamma_{M0}}{2 t f_y} + \frac{d_0}{3}$
<p>Type B:</p>	<p>Given geometry</p>  $t \geq 0,7 \sqrt{\frac{F_{Ed} \gamma_{M0}}{f_y}} : d_0 \leq 2,5 t$

- (4) Pin connected members should be arranged such to avoid eccentricity and should be of sufficient size to distribute the load from the area of the member with the pin hole into the member away from the pin.

3.13.2 Design of pins

- (1) The design requirements for solid circular pins are given in Table 3.10.
- (2) The moments in a pin should be calculated on the basis that the connected parts form simple supports. It should be generally assumed that the reactions between the pin and the connected parts are uniformly distributed along the length in contact on each part as indicated in Figure 3.11.
- (3) If the pin is intended to be replaceable, in addition to the provisions given in 3.13.1 to 3.13.2, the contact bearing stress should satisfy:

$$\sigma_{h,Ed} \leq f_{h,Rd} \quad \dots (3.14)$$

where:

$$\sigma_{h,Ed} = 0,591 \sqrt{\frac{E F_{b,Ed,ser} (d_0 - d)}{d^2 t}} \quad \dots (3.15)$$

$$f_{h,Rd} = 2,5 f_y / \gamma_{M6,scr} \quad \dots (3.16)$$

where:

d is the diameter of the pin;

d_0 is the diameter of the pin hole;

$F_{b,Ed,ser}$ is the design value of the force to be transferred in bearing, under the characteristic load combination for serviceability limit states.

Table 3.10: Design criteria for pin connections

Failure mode	Design requirements
Shear resistance of the pin	$F_{v,Rd} = 0,6 A f_{up} / \gamma_{M2} \geq F_{v,Ed}$
Bearing resistance of the plate and the pin	$F_{b,Rd} = 1,5 t d f_y / \gamma_{M0} \geq F_{b,Ed}$
If the pin is intended to be replaceable this requirement should also be satisfied.	$F_{b,Rd,ser} = 0,6 t d f_y / \gamma_{M6,scr} \geq F_{b,Ed,ser}$
Bending resistance of the pin	$M_{Rd} = 1,5 W_{ef} f_{yp} / \gamma_{M0} \geq M_{Ed}$
If the pin is intended to be replaceable this requirement should also be satisfied.	$M_{Rd,scr} = 0,8 W_{ef} f_{yp} / \gamma_{M6,scr} \geq M_{Ed,ser}$
Combined shear and bending resistance of the pin	$\left[\frac{M_{Ed}}{M_{Rd}} \right]^2 + \left[\frac{F_{v,Ed}}{F_{v,Rd}} \right]^2 \leq 1$
<p>d is the diameter of the pin;</p> <p>f_y is $\langle AC2 \rangle$ the lower of the yield strengths $\langle AC2 \rangle$ of the pin and the connected part;</p> <p>f_{up} is the ultimate tensile strength of the pin;</p> <p>f_{yp} is the yield strength of the pin;</p> <p>t is the thickness of the connected part;</p> <p>A is the cross-sectional area of a pin.</p>	

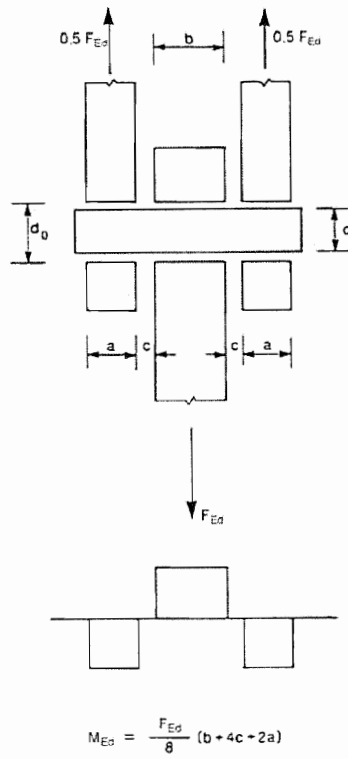


Figure 3.11: Bending moment in a pin

4 Welded connections

4.1 General

- (1) The provisions in this section apply to weldable structural steels conforming to EN 1993-1-1 and to material thicknesses of 4 mm and over. The provisions also apply to joints in which the mechanical properties of the weld metal are compatible with those of the parent metal, see 4.2.

For welds in thinner material reference should be made to EN 1993 part 1.3 and for welds in structural hollow sections in material thicknesses of 2,5 mm and over guidance is given section 7 of this Standard.

For stud welding reference should be made to EN 1994-1-1.

NOTE: Further guidance on stud welding can be found in EN ISO 14555 and EN ISO 13918.

AC1 (2)P Welds subject to fatigue shall also satisfy the principles given in EN 1993-1-9. **AC1**

- (3) Quality level C according to EN ISO 25817 is usually required, if not otherwise specified. The frequency of inspection of welds should be specified in accordance with the rules in 1.2.7 Reference Standards: Group 7. The quality level of welds should be chosen according to EN ISO 25817. For the quality level of welds used in fatigue loaded structures, see EN 1993-1-9.
- (4) Lamellar tearing should be avoided.
- (5) Guidance on lamellar tearing is given in EN 1993-1-10.

4.2 Welding consumables

- (1) All welding consumables should conform to the relevant standards specified in 1.2.5 Reference Standards; Group 5.
- (2) The specified yield strength, ultimate tensile strength, elongation at failure and minimum Charpy V-notch energy value of the filler metal, should be equivalent to, or better than that specified for the parent material.

NOTE: Generally it is safe to use electrodes that are overmatched with regard to the steel grades being used.

4.3 Geometry and dimensions

4.3.1 Type of weld

- (1) This Standard covers the design of fillet welds, fillet welds all round, butt welds, plug welds and flare groove welds. Butt welds may be either full penetration butt welds or partial penetration butt welds. Both fillet welds all round and plug welds may be either in circular holes or in elongated holes.
- (2) The most common types of joints and welds are illustrated in EN 12345.

4.3.2 Fillet welds

4.3.2.1 General

- (1) Fillet welds may be used for connecting parts where the fusion faces form an angle of between 60° and 120°.

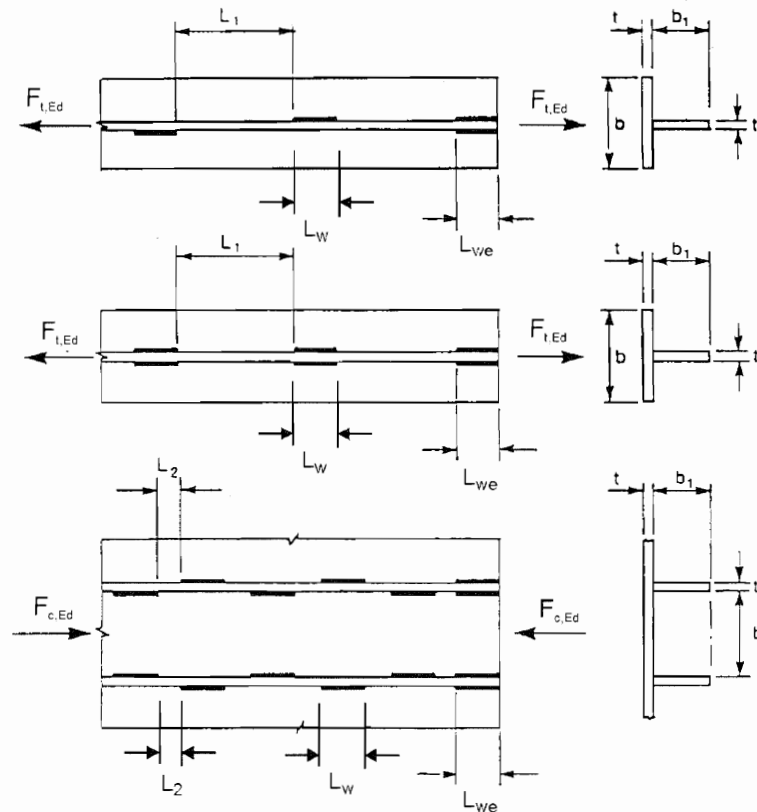
- (2) Angles smaller than 60° are also permitted. However, in such cases the weld should be considered to be a partial penetration butt weld.
- (3) For angles greater than 120° the resistance of fillet welds should be determined by testing in accordance with EN 1990 Annex D: Design by testing.
- (4) Fillet welds finishing at the ends or sides of parts should be returned continuously, full size, around the corner for a distance of at least twice the leg length of the weld, unless access or the configuration of the joint renders this impracticable.

NOTE: In the case of intermittent welds this rule applies only to the last intermittent fillet weld at corners.

- (5) End returns should be indicated on the drawings.
- (6) For eccentricity of single-sided fillet welds, see 4.12.

4.3.2.2 Intermittent fillet welds

- (1) Intermittent fillet welds should not be used in corrosive conditions.
- (2) In an intermittent fillet weld, the gaps (L_1 or L_2) between the ends of each length of weld L_w should fulfil the requirement given in Figure 4.1.
- (3) In an intermittent fillet weld, the gap (L_1 or L_2) should be taken as the smaller of the distances between the ends of the welds on opposite sides and the distance between the ends of the welds on the same side.
- (4) In any run of intermittent fillet weld there should always be a length of weld at each end of the part connected.
- (5) In a built-up member in which plates are connected by means of intermittent fillet welds, a continuous fillet weld should be provided on each side of the plate for a length at each end equal to at least three-quarters of the width of the narrower plate concerned (see Figure 4.1).



The smaller of $L_{we} \geq 0,75 b$ and $0,75 b_1$

For build-up members in tension:

The smallest of $L_1 \leq 16 t$ and $16 t_1$ and 200 mm

For build-up members in compression or shear:

The smallest of $L_2 \leq 12 t$ and $12 t_1$ and $0,25 b$ and 200 mm

Figure 4.1: Intermittent fillet welds

4.3.3 Fillet welds all round

- (1) Fillet welds all round, comprising fillet welds in circular or elongated holes, may be used only to transmit shear or to prevent the buckling or separation of lapped parts.
- (2) The diameter of a circular hole, or width of an elongated hole, for a fillet weld all round should not be less than four times the thickness of the part containing it.
- (3) The ends of elongated holes should be semi-circular, except for those ends which extend to the edge of the part concerned.
- (4) The centre to centre spacing of fillet welds all round should not exceed the value necessary to prevent local buckling, see Table 3.3.

4.3.4 Butt welds

- (1) A full penetration butt weld is defined as a weld that has complete penetration and fusion of weld and parent metal throughout the thickness of the joint.

- (2) A partial penetration butt weld is defined as a weld that has joint penetration which is less than the full thickness of the parent material.
- (3) Intermittent butt welds should not be used.
- (4) For eccentricity in single-sided partial penetration butt welds, see 4.12.

4.3.5 Plug welds

- (1) Plug welds may be used:

- to transmit shear,
- to prevent the buckling or separation of lapped parts, and
- to inter-connect the components of built-up members

but should not be used to resist externally applied tension.

- (2) The diameter of a circular hole, or width of an elongated hole, for a plug weld should be at least 8 mm more than the thickness of the part containing it.
- (3) The ends of elongated holes should either be semi-circular or else should have corners which are rounded to a radius of not less than the thickness of the part containing the slot, except for those ends which extend to the edge of the part concerned.
- (4) The thickness of a plug weld in parent material up to 16 mm thick should be equal to the thickness of the parent material. The thickness of a plug weld in parent material over 16 mm thick should be at least half the thickness of the parent material and not less than 16 mm.
- (5) The centre to centre spacing of plug welds should not exceed the value necessary to prevent local buckling, see Table 3.3.

4.3.6 Flare groove welds

- (1) For solid bars the design effective throat thickness of flare groove welds, when fitted flush to the surface of the solid section of the bars, is defined in Figure 4.2. The definition of the design throat thickness of flare groove welds in rectangular hollow sections is given in 7.3.1(7).

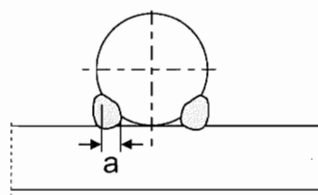


Figure 4.2: Effective throat thickness of flare groove welds in solid sections

4.4 Welds with packings

- (1) In the case of welds with packing, the packing should be trimmed flush with the edge of the part that is to be welded.
- (2) Where two parts connected by welding are separated by packing having a thickness less than the leg length of weld necessary to transmit the force, the required leg length should be increased by the thickness of the packing.

- (3) Where two parts connected by welding are separated by packing having a thickness equal to, or greater than, the leg length of weld necessary to transmit the force, each of the parts should be connected to the packing by a weld capable of transmitting the design force.

4.5 Design resistance of a fillet weld

4.5.1 Length of welds

- (1) $\overline{AC2}$ The effective length of a fillet weld l_{eff} $\overline{AC2}$ should be taken as the length over which the fillet is full-size. This may be taken as the overall length of the weld reduced by twice the effective throat thickness a . Provided that the weld is full size throughout its length including starts and terminations, no reduction in effective length need be made for either the start or the termination of the weld.
- (2) A fillet weld with an effective length less than 30 mm or less than 6 times its throat thickness, whichever is larger, should not be designed to carry load.

4.5.2 Effective throat thickness

- (1) The effective throat thickness, a , of a fillet weld should be taken as the height of the largest triangle (with equal or unequal legs) that can be inscribed within the fusion faces and the weld surface, measured perpendicular to the outer side of this triangle, see Figure 4.3.
- (2) The effective throat thickness of a fillet weld should not be less than 3 mm.
- (3) In determining the design resistance of a deep penetration fillet weld, account may be taken of its additional throat thickness, see Figure 4.4, provided that preliminary tests show that the required penetration can consistently be achieved.

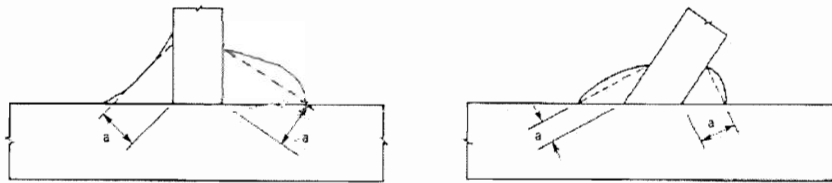


Figure 4.3: Throat thickness of a fillet weld

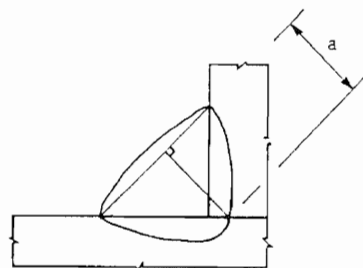


Figure 4.4: Throat thickness of a deep penetration fillet weld

4.5.3 Design Resistance of fillet welds

4.5.3.1 General

- (1) The design resistance of a fillet weld should be determined using either the Directional method given in 4.5.3.2 or the Simplified method given in 4.5.3.3.

4.5.3.2 Directional method

- (1) In this method, the forces transmitted by a unit length of weld are resolved into components parallel and transverse to the longitudinal axis of the weld and normal and transverse to the plane of its throat.
- (2) The design throat area A_w should be taken as $A_w = \sum a \ell_{\text{eff}}$.
- (3) The location of the design throat area should be assumed to be concentrated in the root.
- (4) A uniform distribution of stress is assumed on the throat section of the weld, leading to the normal stresses and shear stresses shown in Figure 4.5, as follows:
 - σ_{\perp} is the normal stress perpendicular to the throat
 - σ_{\parallel} is the normal stress parallel to the axis of the weld
 - τ_{\perp} is the shear stress (in the plane of the throat) perpendicular to the axis of the weld
 - τ_{\parallel} is the shear stress (in the plane of the throat) parallel to the axis of the weld.

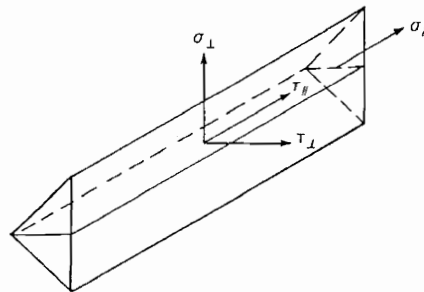


Figure 4.5: Stresses on the throat section of a fillet weld

- (5) The normal stress σ_{\parallel} parallel to the axis is not considered when verifying the design resistance of the weld.
- (6) The design resistance of the fillet weld will be sufficient if the following are both satisfied:

$$[\sigma_{\perp}^2 + 3(\tau_{\perp}^2 + \tau_{\parallel}^2)]^{0.5} \leq f_u / (\beta_w \gamma_{M2}) \quad \text{and} \quad \sigma_{\perp} \leq 0.9 f_u / \gamma_{M2} \quad \dots (4.1)$$

where:

- f_u is the nominal ultimate tensile strength of the weaker part joined;
- β_w is the appropriate correlation factor taken from Table 4.1.

- (7) Welds between parts with different material strength grades should be designed using the properties of the material with the lower strength grade.

Table 4.1: Correlation factor β_w for fillet welds

Standard and steel grade			Correlation factor β_w
EN 10025	EN 10210	EN 10219	
S 235 S 235 W	S 235 H	S 235 H	0,8
S 275 S 275 N/NL S 275 M/ML	S 275 H S 275 NH/NLH	S 275 H S 275 NH/NLH S 275 MH/MLH	0,85
S 355 S 355 N/NL S 355 M/ML S 355 W	S 355 H S 355 NH/NLH	S 355 H S 355 NH/NLH S 355 MH/MLH	0,9
S 420 N/NL S 420 M/ML		S 420 MH/MLH	1,0
S 460 N/NL S 460 M/ML S 460 Q/QL/QL1	S 460 NH/NLH	S 460 NH/NLH S 460 MH/MLH	1,0

4.5.3.3 Simplified method for design resistance of fillet weld

- (1) Alternatively to 4.5.3.2 the design resistance of a fillet weld may be assumed to be adequate if, at every point along its length, the resultant of all the forces per unit length transmitted by the weld satisfy the following criterion:

$$F_{w,Ed} \leq F_{w,Rd} \quad \dots (4.2)$$

where:

$F_{w,Ed}$ is the design value of the weld force per unit length;

$F_{w,Rd}$ is the design weld resistance per unit length.

- (2) Independent of the orientation of the weld throat plane to the applied force, the design resistance per unit length $F_{w,Rd}$ should be determined from:

$$F_{w,Rd} = f_{vw,d} a \quad \dots (4.3)$$

where:

$f_{vw,d}$ is the design shear strength of the weld.

- (3) The design shear strength $f_{vw,d}$ of the weld should be determined from:

$$f_{vw,d} = \frac{f_u / \sqrt{3}}{\beta_w \gamma_{M2}} \quad \dots (4.4)$$

where:

f_u and β_w are defined in 4.5.3.2(6).

4.6 Design resistance of fillet welds all round

- (1) The design resistance of a fillet weld all round should be determined using one of the methods given in 4.5.

4.7 Design resistance of butt welds

4.7.1 Full penetration butt welds

- (1) The design resistance of a full penetration butt weld should be taken as equal to the design resistance of the weaker of the parts connected, provided that the weld is made with a suitable consumable which will produce all-weld tensile specimens having both a minimum yield strength and a minimum tensile strength not less than those specified for the parent metal.

4.7.2 Partial penetration butt welds

- (1) The design resistance of a partial penetration butt weld should be determined using the method for a deep penetration fillet weld given in 4.5.2(3).
- (2) The throat thickness of a partial penetration butt weld should not be greater than the depth of penetration that can be consistently achieved, see 4.5.2(3).

4.7.3 T-butt joints

- (1) The design resistance of a T-butt joint, consisting of a pair of partial penetration butt welds reinforced by superimposed fillet welds, may be determined as for a full penetration butt weld (see 4.7.1) if the total nominal throat thickness, exclusive of the unwelded gap, is not less than the thickness t of the part forming the stem of the tee joint, provided that the unwelded gap is not more than $(t/5)$ or 3 mm, whichever is less, see AC2 Figure 4.6 AC2.
- (2) The design resistance of a T-butt joint which does not meet the requirements given in 4.7.3(1) should be determined using the method for a fillet weld or a deep penetration fillet weld given in 4.5 depending on the amount of penetration. The throat thickness should be determined in conformity with the provisions for fillet welds (see 4.5.2) or partial penetration butt welds (see 4.7.2) as relevant.

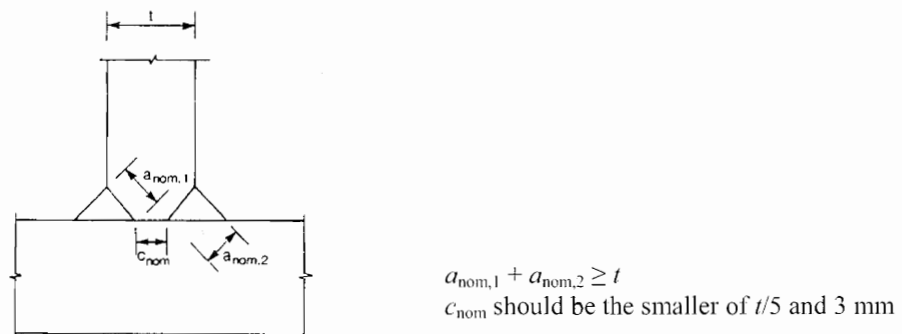


Figure 4.6: Effective full penetration of T-butt welds

4.8 Design resistance of plug welds

- (1) The design resistance $F_{w,Rd}$ of a plug weld (see 4.3.3) should be taken as:

$$F_{w,Rd} = f_{vw,d} A_w, \quad \dots (4.5)$$

where

$f_{vw,d}$ is the design shear strength of a weld given in 4.5.3.3(3);

A_w is the design throat area and should be taken as the area of the hole.

4.9 Distribution of forces

- (1) The distribution of forces in a welded connection may be calculated on the assumption of either elastic or plastic behaviour in conformity with 2.4 and 2.5.
- (2) It is acceptable to assume a simplified load distribution within the welds.
- (3) Residual stresses and stresses not subjected to transfer of load need not be included when checking the resistance of a weld. This applies specifically to the normal stress parallel to the axis of a weld.
- (4) Welded joints should be designed to have adequate deformation capacity. However, ductility of the welds should not be relied upon.
- (5) In joints where plastic hinges may form, the welds should be designed to provide at least the same design resistance as the weakest of the connected parts.
- (6) In other joints where deformation capacity for joint rotation is required due to the possibility of excessive straining, the welds require sufficient strength not to rupture before general yielding in the adjacent parent material.
- (7) If the design resistance of an intermittent weld is determined by using the total length l_{tot} , the weld shear force per unit length $F_{w,Ed}$ should be multiplied by the factor $(e+l)/l$, see Figure 4.7.

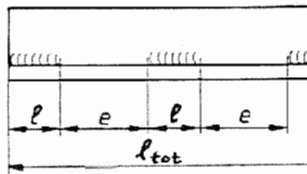


Figure 4.7: Calculation of weld forces for intermittent welds

4.10 Connections to unstiffened flanges

- (1) Where a transverse plate (or beam flange) is welded to a supporting unstiffened flange of an I, H or other section, see Figure 4.8, and provided that the condition given in 4.10(3) is met, the applied force perpendicular to the unstiffened flange should not exceed any of the relevant design resistances as follows:
 - that of the web of the supporting member of I or H sections as given in 6.2.6.2 or 6.2.6.3 as appropriate;
 - those for a transverse plate on a RHS member as given in Table 7.13;
 - that of the supporting flange as given by formula (6.20) in 6.2.6.4.3(1) calculated assuming the applied force is concentrated over an effective width, b_{eff} , of the flange as given in 4.10(2) or 4.10(4) as relevant.

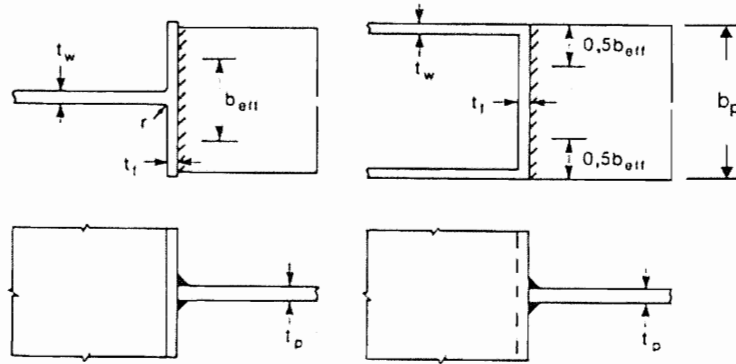


Figure 4.8: Effective width of an unstiffened T-joint

- (2) For an unstiffened I or H section the effective width b_{eff} should be obtained from:

$$b_{\text{eff}} = t_w + 2s + 7kt_f \quad \dots (4.6a)$$

where:

$$k = (t_f / t_p)(f_{y,f} / f_{y,p}) \text{ but } k \leq 1 \quad \dots (4.6b)$$

$f_{y,f}$ is the yield strength of the flange of the I or H section;

$f_{y,p}$ is the yield strength of the plate welded to the I or H section.

The dimension s should be obtained from:

– for a rolled I or H section: $s = r$... (4.6c)

– for a welded I or H section: $s = \sqrt{2} a$... (4.6d)

- (3) For an unstiffened flange of an I or H section, the following criterion should be satisfied:

$$b_{\text{eff}} \geq (f_{y,p} / f_{u,p}) b_p \quad \dots (4.7)$$

where:

$f_{u,p}$ is the ultimate strength of the plate welded to the I or H section;

b_p is the width of the plate welded to the I or H section.

Otherwise the joint should be stiffened.

- (4) For other sections such as box sections or channel sections where the width of the connected plate is similar to the width of the flange, the effective width b_{eff} should be obtained from:

$$b_{\text{eff}} = 2t_w + 5t_f \quad \text{but} \quad b_{\text{eff}} \leq 2t_w + 5k t_f \quad \dots (4.8)$$

NOTE: For hollow sections, see Table 7.13.

- (5) Even if $b_{\text{eff}} \leq b_p$, the welds connecting the plate to the flange need to be designed to transmit the design resistance of the plate $b_p t_p f_{y,p} / \gamma_{M0}$ assuming a uniform stress distribution.

4.11 Long joints

- (1) In lap joints the design resistance of a fillet weld should be reduced by multiplying it by a reduction factor β_{Lw} to allow for the effects of non-uniform distribution of stress along its length.
- (2) The provisions given in 4.11 do not apply when the stress distribution along the weld corresponds to the stress distribution in the adjacent base metal, as, for example, in the case of a weld connecting the flange and the web of a plate girder.
- (3) In lap joints longer than $150a$ the reduction factor β_{Lw} should be taken as $\beta_{Lw,1}$ given by:

$$\beta_{Lw,1} = 1,2 - 0,2L_j / (150a) \quad \text{but} \quad \beta_{Lw,1} \leq 1,0 \quad \dots (4.9)$$

where:

L_j is the overall length of the lap in the direction of the force transfer.

- (4) For fillet welds longer than 1,7 metres connecting transverse stiffeners in plated members, the reduction factor β_{Lw} may be taken as $\beta_{Lw,2}$ given by:

$$\beta_{Lw,2} = 1,1 - L_w / 17 \quad \text{but} \quad \beta_{Lw,2} \leq 1,0 \quad \text{and} \quad \beta_{Lw,2} \geq 0,6 \quad \dots (4.10)$$

where:

L_w is the length of the weld (in metres).

4.12 Eccentrically loaded single fillet or single-sided partial penetration butt welds

- (1) Local eccentricity should be avoided whenever it is possible.
- (2) Local eccentricity (relative to the line of action of the force to be resisted) should be taken into account in the following cases:
 - Where a bending moment transmitted about the longitudinal axis of the weld produces tension at the root of the weld, see Figure 4.9(a);
 - Where a tensile force transmitted perpendicular to the longitudinal axis of the weld produces a bending moment, resulting in a tension force at the root of the weld, see Figure 4.9(b).
- (3) Local eccentricity need not be taken into account if a weld is used as part of a weld group around the perimeter of a structural hollow section.

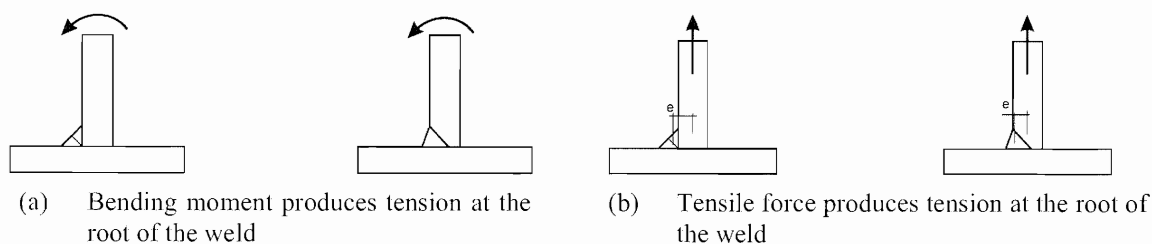


Figure 4.9: Single fillet welds and single-sided partial penetration butt welds

4.13 Angles connected by one leg

- (1) In angles connected by one leg, the eccentricity of welded lap joint end connections may be allowed for by adopting an effective cross-sectional area and then treating the member as concentrically loaded.
- (2) For an equal-leg angle, or an unequal-leg angle connected by its larger leg, the effective area may be taken as equal to the gross area.

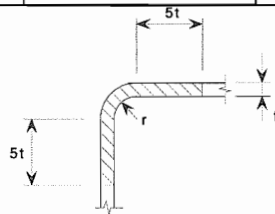
- (3) For an unequal-leg angle connected by its smaller leg, the effective area should be taken as equal to the gross cross-sectional area of an equivalent equal-leg angle of leg size equal to that of the smaller leg, when determining the design resistance of the cross-section, see EN 1993-1-1. However when determining the design buckling resistance of a compression member, see EN 1993-1-1, the actual gross cross-sectional area should be used.

4.14 Welding in cold-formed zones

- (1) Welding may be carried out within a length $5t$ either side of a cold-formed zone, see Table 4.2, provided that one of the following conditions is fulfilled:
- the cold-formed zones are normalized after cold-forming but before welding;
 - the r/t -ratio satisfy the relevant value obtained from Table 4.2.

Table 4.2: Conditions for welding cold-formed zones and adjacent material

r/t	Strain due to cold forming (%)	Maximum thickness (mm)		
		Generally		Fully killed Aluminium-killed steel (Al \geq 0,02 %)
		Predominantly static loading	Where fatigue predominates	
≥ 25	≤ 2	any	any	any
≥ 10	≤ 5	any	16	any
$\geq 3,0$	≤ 14	24	12	24
$\geq 2,0$	≤ 20	12	10	12
$\geq 1,5$	≤ 25	8	8	10
$\geq 1,0$	≤ 33	4	4	6



AC2 NOTE Cold formed hollow sections according to EN 10.219 which do not satisfy the limits given in Table 4.2 can be assumed to satisfy these limits if these sections have a thickness not exceeding 12,5 mm and are Al-killed with a quality J2H, K2H, MH, MLH, NH or NLH and further satisfy $C \leq 0,18\%$, $P \leq 0,020\%$ and $S \leq 0,012\%$.

In other cases welding is only permitted within a distance of $5t$ from the corners if it can be shown by tests that welding is permitted for that particular application. **AC2**

5 Analysis, classification and modelling

5.1 Global analysis

5.1.1 General

- (1) The effects of the behaviour of the joints on the distribution of internal forces and moments within a structure, and on the overall deformations of the structure, should generally be taken into account, but where these effects are sufficiently small they may be neglected.
- (2) To identify whether the effects of joint behaviour on the analysis need be taken into account, a distinction may be made between three simplified joint models as follows:
 - simple, in which the joint may be assumed not to transmit bending moments;
 - continuous, in which the behaviour of the joint may be assumed to have no effect on the analysis;
 - semi-continuous, in which the behaviour of the joint needs to be taken into account in the analysis.
- (3) The appropriate type of joint model should be determined from Table 5.1, depending on the classification of the joint and on the chosen method of analysis.
- (4) The design moment-rotation characteristic of a joint used in the analysis may be simplified by adopting any appropriate curve, including a linearized approximation (e.g. bi-linear or tri-linear), provided that the approximate curve lies wholly below the design moment-rotation characteristic.

Table 5.1: Type of joint model

Method of global analysis	Classification of joint		
	Nominally pinned	Rigid	Semi-rigid
Elastic	Nominally pinned	Rigid	Semi-rigid
Rigid-Plastic	Nominally pinned	Full-strength	Partial-strength
Elastic-Plastic	Nominally pinned	Rigid and full-strength	Semi-rigid and partial-strength Semi-rigid and full-strength Rigid and partial-strength
Type of joint model	Simple	Continuous	Semi-continuous

5.1.2 Elastic global analysis

- (1) The joints should be classified according to their rotational stiffness, see 5.2.2.
- (2) The joints should have sufficient strength to transmit the forces and moments acting at the joints resulting from the analysis.
- (3) In the case of a semi-rigid joint, the rotational stiffness S_j corresponding to the bending moment $M_{j,Ed}$ should generally be used in the analysis. If $M_{j,Ed}$ does not exceed $2/3 M_{j,Rd}$ the initial rotational stiffness $S_{j,ini}$ may be taken in the global analysis, see Figure 5.1(a).
- (4) As a simplification to 5.1.2(3), the rotational stiffness may be taken as $S_{j,ini}/\eta$ in the analysis, for all values of the moment $M_{j,Ed}$, as shown in Figure 5.1(b), where η is the stiffness modification coefficient from Table 5.2.
- (5) For joints connecting H or I sections S_j is given in 6.3.1.

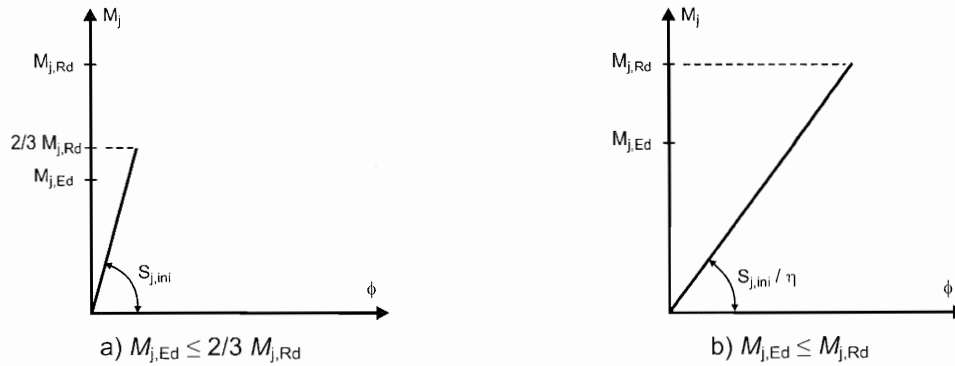


Figure 5.1: Rotational stiffness to be used in elastic global analysis

Table 5.2: Stiffness modification coefficient η

Type of connection	Beam-to-column joints	Other types of joints (beam-to-beam joints, beam splices, column base joints)
Welded	2	3
Bolted end-plates	2	3
Bolted flange cleats	2	3,5
Base plates	-	3

5.1.3 Rigid-plastic global analysis

- (1) The joints should be classified according to their strength, see 5.2.3.
- (2) For joints connecting H or I sections $M_{j,Rd}$ is given in 6.2.
- (3) For joints connecting hollow sections the method given in section 7 may be used.
- (4) The rotation capacity of a joint should be sufficient to accommodate the rotations resulting from the analysis.
- (5) For joints connecting H or I sections the rotation capacity should be checked according to 6.4.

5.1.4 Elastic-plastic global analysis

- (1) The joints should be classified according to both stiffness (see 5.2.2) and strength (see 5.2.3).
- (2) For joints connecting H or I sections $M_{j,Rd}$ is given in 6.2, S_j is given in 6.3.1 and ϕ_{Cd} is given in 6.4.
- (3) For joints connecting hollow sections the method given in section 7 may be used.
- (4) The moment rotation characteristic of the joints should be used to determine the distribution of internal forces and moments.
- (5) As a simplification, the bi-linear design moment-rotation characteristic shown in Figure 5.2 may be adopted. The stiffness modification coefficient η should be obtained from Table 5.2.

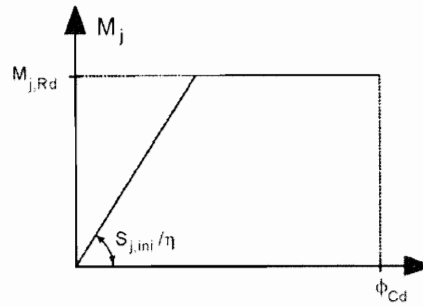


Figure 5.2: Simplified bi-linear design moment-rotation characteristic

5.1.5 Global analysis of lattice girders

- (1) The provisions given in 5.1.5 apply only to structures whose joints are verified according to section 7.
- (2) The distribution of axial forces in a lattice girder may be determined on the assumption that the members are connected by pinned joints (see also 2.7).
- (3) Secondary moments at the joints, caused by the rotational stiffnesses of the joints, may be neglected both in the design of the members and in the design of the joints, provided that both of the following conditions are satisfied:
 - the joint geometry is within the range of validity specified in Table 7.1, Table 7.8, Table 7.9 or Table 7.20 as appropriate;
 - the ratio of the system length to the depth of the member in the plane of the lattice girder is not less than the appropriate minimum value. For building structures, the appropriate minimum value may be assumed to be 6. Larger values may apply in other parts of EN 1993;
- AC2 - the eccentricity is within the limits specified in 5.1.5(5). AC2
- (4) The moments resulting from transverse loads (whether in-plane or out-of-plane) that are applied between panel points, should be taken into account in the design of the members to which they are applied. Provided that the conditions given in 5.1.5(3) are satisfied:
 - the brace members may be considered as pin-connected to the chords, so moments resulting from transverse loads applied to chord members need not be distributed into brace members, and vice versa;
 - the chords may be considered as continuous beams, with simple supports at panel points.
- (5) Moments resulting from eccentricities may be neglected in the design of tension chord members and brace members. They may also be neglected in the design of connections if the eccentricities are within the following limits:

$$-0,55 d_0 \leq e \leq 0,25 d_0 \quad \dots (5.1a)$$

$$-0,55 h_0 \leq e \leq 0,25 h_0 \quad \dots (5.1b)$$

where:

e is the eccentricity defined in Figure 5.3;

d_0 is the diameter of the chord;

h_0 is the depth of the chord, in the plane of the lattice girder.

- (6) When the eccentricities are within the limits given in 5.1.5(5), the moments resulting from the eccentricities should be taken into account in the design of compression chord members. In this case the moments produced by the eccentricity should be distributed between the compression chord

members on each side of the joint, on the basis of their relative stiffness coefficients I/L , where L is the system length of the member, measured between panel points.

- (7) When the eccentricities are outside the limits given in 5.1.5(5), the moments resulting from the eccentricities should be taken into account in the design of the joints $\boxed{AC_2}$ and the members $\boxed{AC_2}$. In this case the moments produced by the eccentricity should be distributed between all the members meeting at the joint, on the basis of their relative stiffness coefficients I/L .
- (8) The stresses in a chord resulting from moments taken into account in the design of the chord, should also be taken into account in determining the factors k_m , k_n and k_p used in the design of the joints, see Table 7.2 to Table 7.5, Table 7.10 and Table 7.12 to Table 7.14.
- (9) The cases where moments should be taken into account are summarized in Table 5.3.

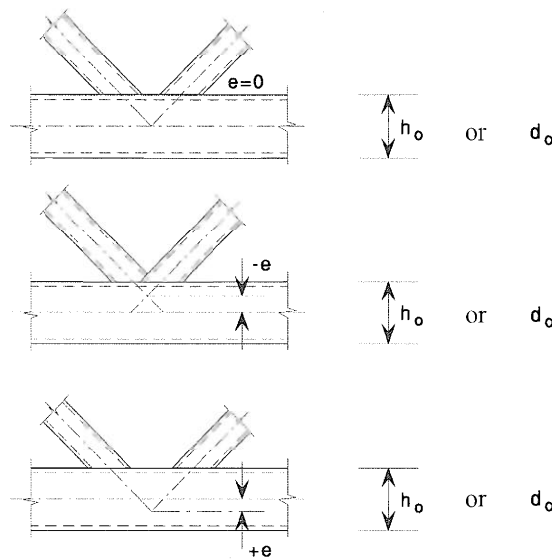


Figure 5.3: Eccentricity of joints

Table 5.3 Allowance for bending moments

Type of component	Source of the bending moment		
	Secondary effects	Transverse loading	Eccentricity
Compression chord	Not if 5.1.5(3) is satisfied	Yes	Yes
Tension chord			$\boxed{AC_2}$ Not if 5.1.5(3) and (5) are satisfied
Brace member			Not if 5.1.5(3) and (5) are satisfied
Joint			Not if 5.1.5(3) and (5) are satisfied $\boxed{AC_2}$

5.2 Classification of joints

5.2.1 General

- (1) The details of all joints should fulfil the assumptions made in the relevant design method, without adversely affecting any other part of the structure.
- (2) Joints may be classified by their stiffness (see 5.2.2) and by their strength (see 5.2.3).

NOTE: The National Annex may give additional information on the classification of joints by their stiffness and strength to that given in 5.2.2.1(2).

5.2.2 Classification by stiffness

5.2.2.1 General

- (1) A joint may be classified as rigid, nominally pinned or semi-rigid according to its rotational stiffness, by comparing its initial rotational stiffness $S_{j,ini}$ with the classification boundaries given in 5.2.2.5.

NOTE: Rules for the determination of $S_{j,ini}$ for joints connecting H or I sections are given in 6.3.1. Rules for the determination of $S_{j,ini}$ for joints connecting hollow sections are not given in this Standard.

- (2) A joint may be classified on the basis of experimental evidence, experience of previous satisfactory performance in similar cases or by calculations based on test evidence.

5.2.2.2 Nominally pinned joints

- (1) A nominally pinned joint should be capable of transmitting the internal forces, without developing significant moments which might adversely affect the members or the structure as a whole.
- (2) A nominally pinned joint should be capable of accepting the resulting rotations under the design loads.

5.2.2.3 Rigid joints

- (1) Joints classified as rigid may be assumed to have sufficient rotational stiffness to justify analysis based on full continuity.

5.2.2.4 Semi-rigid joints

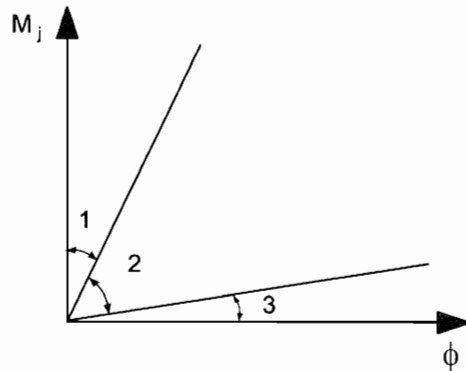
- (1) A joint which does not meet the criteria for a rigid joint or a nominally pinned joint should be classified as a semi-rigid joint.

NOTE: Semi-rigid joints provide a predictable degree of interaction between members, based on the design moment-rotation characteristics of the joints.

- (2) Semi-rigid joints should be capable of transmitting the internal forces and moments.

5.2.2.5 Classification boundaries

- (1) Classification boundaries for joints other than column bases are given in 5.2.2.1(1) and Figure 5.4.



Zone 1: rigid, if $S_{j,ini} \geq k_b EI_b / L_b$

where:

$k_b = 8$ for frames where the bracing system reduces the horizontal displacement by at least 80 %

$k_b = 25$ for other frames, provided that in every storey $K_b/K_c \geq 0,1$ ^{*)}

Zone 2: semi-rigid

All joints in zone 2 should be classified as semi-rigid. Joints in zones 1 or 3 may optionally also be treated as semi-rigid.

Zone 3: nominally pinned, if $S_{j,ini} \leq 0,5 EI_b / L_b$

^{*)} For frames where $K_b/K_c < 0,1$ the joints should be classified as semi-rigid.

Key:

- K_b is the mean value of I_b/L_b for all the beams at the top of that storey;
- K_c is the mean value of I_c/L_c for all the columns in that storey;
- I_b is the second moment of area of a beam;
- I_c is the second moment of area of a column;
- L_b is the span of a beam (centre-to-centre of columns);
- L_c is the storey height of a column.

Figure 5.4: Classification of joints by stiffness

(2) Column bases may be classified as rigid provided the following conditions are satisfied:

- in frames where the bracing system reduces the horizontal displacement by at least 80 % and where the effects of deformation may be neglected:
 - if $\bar{\lambda}_0 \leq 0,5$; ... (5.2a)
 - if $0,5 < \bar{\lambda}_0 < 3,93$ and $S_{j,ini} \geq 7(2\bar{\lambda}_0 - 1)EI_c / L_c$; ... (5.2b)
 - if $\bar{\lambda}_0 \geq 3,93$ and $S_{j,ini} \geq 48 EI_c / L_c$ (5.2c)
- otherwise if $S_{j,ini} \geq 30 EI_c / L_c$ (5.2d)

where:

$\bar{\lambda}_0$ is the slenderness of a column in which both ends are assumed to be pinned;

I_c, L_c are as given in Figure 5.4.

5.2.3 Classification by strength

5.2.3.1 General

(1) A joint may be classified as full-strength, nominally pinned or partial strength by comparing its design moment resistance $M_{j,Rd}$ with the design moment resistances of the members that it connects. When classifying joints, the design resistance of a member should be taken as that member adjacent to the joint.

5.2.3.2 Nominally pinned joints

(1) A nominally pinned joint should be capable of transmitting the internal forces, without developing significant moments which might adversely affect the members or the structure as a whole.

- (2) A nominally pinned joint should be capable of accepting the resulting rotations under the design loads.
- (3) A joint may be classified as nominally pinned if its design moment resistance $M_{j,Rd}$ is not greater than 0,25 times the design moment resistance required for a full-strength joint, provided that it also has sufficient rotation capacity.

5.2.3.3 Full-strength joints

- (1) The design resistance of a full strength joint should be not less than that of the connected members.
- (2) A joint may be classified as full-strength if it meets the criteria given in Figure 5.5.

a) Top of column



$M_{j,Rd}$

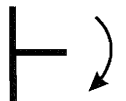
Either

$$M_{j,Rd} \geq M_{b,pt,Rd}$$

or

$$M_{j,Rd} \geq M_{c,pt,Rd}$$

b) Within column height



$M_{j,Rd}$

Either

$$M_{j,Rd} \geq M_{b,pt,Rd}$$

or

$$M_{j,Rd} \geq 2 M_{c,pt,Rd}$$

Key:

$M_{b,pt,Rd}$ is the design plastic moment resistance of a beam;

$M_{c,pt,Rd}$ is the design plastic moment resistance of a column.

Figure 5.5: Full-strength joints

5.2.3.4 Partial-strength joints

- (1) A joint which does not meet the criteria for a full-strength joint or a nominally pinned joint should be classified as a partial-strength joint.

5.3 Modelling of beam-to-column joints

- (1) To model the deformational behaviour of a joint, account should be taken of the shear deformation of the web panel and the rotational deformation of the connections.
- (2) Joint configurations should be designed to resist the internal bending moments $M_{b1,Ed}$ and $M_{b2,Ed}$, normal forces $N_{b1,Ed}$ and $N_{b2,Ed}$ and shear forces $V_{b1,Ed}$ and $V_{b2,Ed}$ applied to the joints by the connected members, see Figure 5.6.
- (3) The resulting shear force $V_{wp,Ed}$ in the web panel should be obtained using:

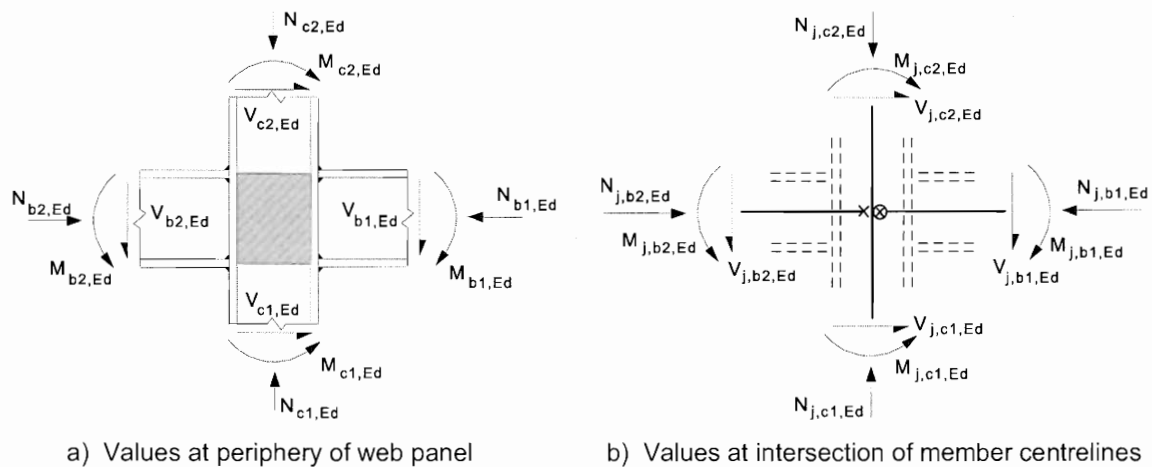
$$V_{wp,Ed} = (M_{b1,Ed} - M_{b2,Ed})/z - (V_{c1,Ed} - V_{c2,Ed})/2 \quad \dots (5.3)$$

where:

z is the lever arm, see 6.2.7.

- (4) To model a joint in a way that closely reproduces the expected behaviour, the web panel in shear and each of the connections should be modelled separately, taking account of the internal moments and forces in the members, acting at the periphery of the web panel, see Figure 5.6(a) and Figure 5.7.
- (5) As a simplified alternative to 5.3(4), a single-sided joint configuration may be modelled as a single joint, and a double-sided joint configuration may be modelled as two separate but inter-acting joints, one on each side. As a consequence a double-sided beam-to-column joint configuration has two moment-rotation characteristics, one for the right-hand joint and another for the left-hand joint.

- (6) In a double-sided, beam-to-column joint each joint should be modelled as a separate rotational spring, as shown in Figure 5.8, in which each spring has a moment-rotation characteristic that takes into account the behaviour of the web panel in shear as well as the influence of the relevant connections.
- (7) When determining the design moment resistance and rotational stiffness for each of the joints, the possible influence of the web panel in shear should be taken into account by means of the transformation parameters β_1 and β_2 , where:
- β_1 is the value of the transformation parameter β for the right-hand side joint;
- β_2 is the value of the transformation parameter β for the left-hand side joint.
- NOTE:** The transformation parameters β_1 and β_2 are used directly in 6.2.7.2(7) and 6.3.2(1). They are also used in 6.2.6.2(1) and 6.2.6.3(4) in connection with Table 6.3 to obtain the reduction factor ω for shear.
- (8) Approximate values for β_1 and β_2 based on the values of the beam moments $M_{b1,Ed}$ and $M_{b2,Ed}$ at the periphery of the web panel, see Figure 5.6(a), may be obtained from Table 5.4.



Direction of forces and moments are considered as positive in relation to equations (5.3) and (5.4)

Figure 5.6: Forces and moments acting on the joint

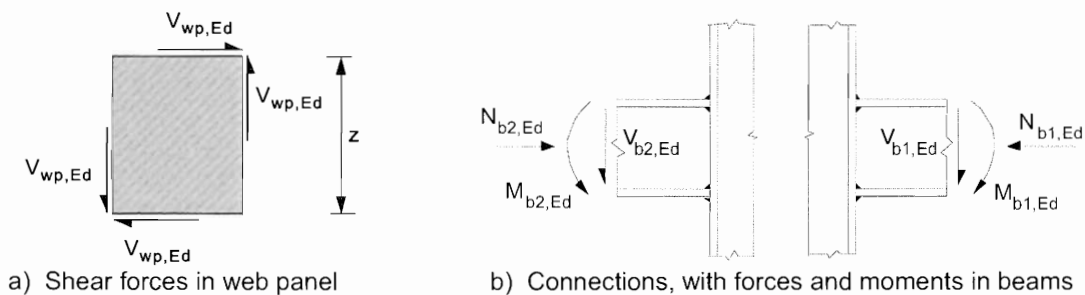


Figure 5.7: Forces and moments acting on the web panel at the connections

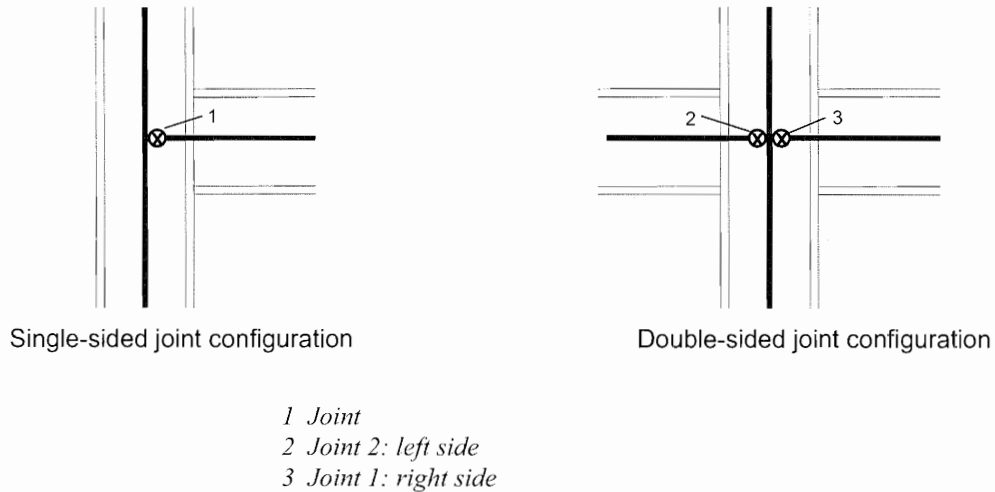


Figure 5.8: Modelling the joint

- (9) As an alternative to 5.3(8), more accurate values of β_1 and β_2 based on the values of the beam moments $M_{j,b1,Ed}$ and $M_{j,b2,Ed}$ at the intersection of the member centrelines, may be determined from the simplified model shown in Figure 5.6(b) as follows:

$$\beta_1 = \left| 1 - M_{j,b2,Ed} / M_{j,b1,Ed} \right| \leq 2 \quad \dots (5.4a)$$

$$\beta_2 = \left| 1 - M_{j,b1,Ed} / M_{j,b2,Ed} \right| \leq 2 \quad \dots (5.4b)$$

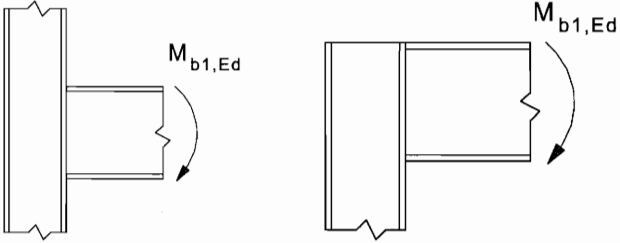
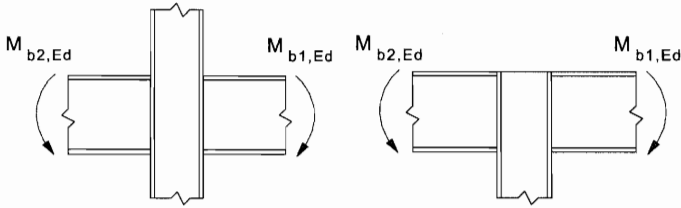
where:

$M_{j,b1,Ed}$ is the moment at the intersection from the right hand beam;

$M_{j,b2,Ed}$ is the moment at the intersection from the left hand beam.

- (10) In the case of an unstiffened double-sided beam-to-column joint configuration in which the depths of the two beams are not equal, the actual distribution of shear stresses in the column web panel should be taken into account when determining the design moment resistance.

Table 5.4: Approximate values for the transformation parameter β

Type of joint configuration	Action	Value of β
	$M_{b1,Ed}$	$\beta \approx 1$
	$M_{b1,Ed} = M_{b2,Ed}$	$\beta = 0$ *)
	$M_{b1,Ed} / M_{b2,Ed} > 0$	$\beta \approx 1$
	$M_{b1,Ed} / M_{b2,Ed} < 0$	$\beta \approx 2$
	$M_{b1,Ed} + M_{b2,Ed} = 0$	$\beta \approx 2$
<p>*) In this case the value of β is the exact value rather than an approximation.</p>		

6 Structural joints connecting H or I sections

6.1 General

6.1.1 Basis

- (1) This section contains design methods to determine the structural properties of joints in frames of any type. To apply these methods, a joint should be modelled as an assembly of basic components, see 1.4(1).
- (2) The basic components used in this Standard are identified in Table 6.1 and their properties should be determined in accordance with the provisions given in this Standard. Other basic components may be used provided their properties are based on tests or analytical and numerical methods supported by tests, see EN 1990.

NOTE: The design methods for basic joint components given in this Standard are of general application and can also be applied to similar components in other joint configurations. However the specific design methods given for determining the design moment resistance, rotational stiffness and rotation capacity of a joint are based on an assumed distribution of internal forces for joint configurations indicated in Figure 1.2. For other joint configurations, design methods for determining the design moment resistance, rotational stiffness and rotation capacity should be based on appropriate assumptions for the distribution of internal forces.

6.1.2 Structural properties

6.1.2.1 Design moment-rotation characteristic

- (1) A joint may be represented by a rotational spring connecting the centre lines of the connected members at the point of intersection, as indicated in Figure 6.1(a) and (b) for a single-sided beam-to-column joint configuration. The properties of the spring can be expressed in the form of a design moment-rotation characteristic that describes the relationship between the bending moment $M_{j,Ed}$ applied to a joint and the corresponding rotation ϕ_{Ed} between the connected members. Generally the design moment-rotation characteristic is non-linear as indicated in Figure 6.1(c).
- (2) A design moment-rotation characteristic, see Figure 6.1(c) should define the following three main structural properties:
 - moment resistance;
 - rotational stiffness;
 - rotation capacity.

NOTE: In certain cases the actual moment-rotation behaviour of a joint includes some rotation due to such effects as bolt slip, lack of fit and, in the case of column bases, foundation-soil interactions. This can result in a significant amount of initial hinge rotation that may need to be included in the design moment-rotation characteristic.

- (3) The design moment-rotation characteristics of a beam-to-column joint should be consistent with the assumptions made in the global analysis of the structure and with the assumptions made in the design of the members, see EN 1993-1-1.
- (4) The design moment-rotation characteristic for joints and column bases of I and H sections as obtained from 6.3.1(4) may be assumed to satisfy the requirements of 5.1.1(4) for simplifying this characteristic for global analysis purposes.

6.1.2.2 Design Moment resistance

- (1) The design moment resistance $M_{j,Rd}$, which is equal to the maximum moment of the design moment-rotation characteristic, see Figure 6.1(c), should be taken as that given by 6.1.3(4)

6.1.2.3 Rotational stiffness

- (1) The rotational stiffness S_j , which is the secant stiffness as indicated in Figure 6.1(c), should be taken as that given by 6.3.1(4). For a design moment-rotation characteristic this definition of S_j applies up to the rotation ϕ_{Xd} at which $M_{j,Ed}$ first reaches $M_{j,Rd}$, but not for larger rotations, see Figure 6.1(c). The initial rotational stiffness $S_{j,ini}$, which is the slope of the elastic range of the design moment-rotation characteristic, should be taken as that given by 6.1.3(4).

6.1.2.4 Rotation capacity

- (1) The design rotation capacity ϕ_{Cd} of a joint, which is equal to the maximum rotation of the design moment-rotation characteristic, see Figure 6.1(c), should be taken as that given by 6.1.3(4).

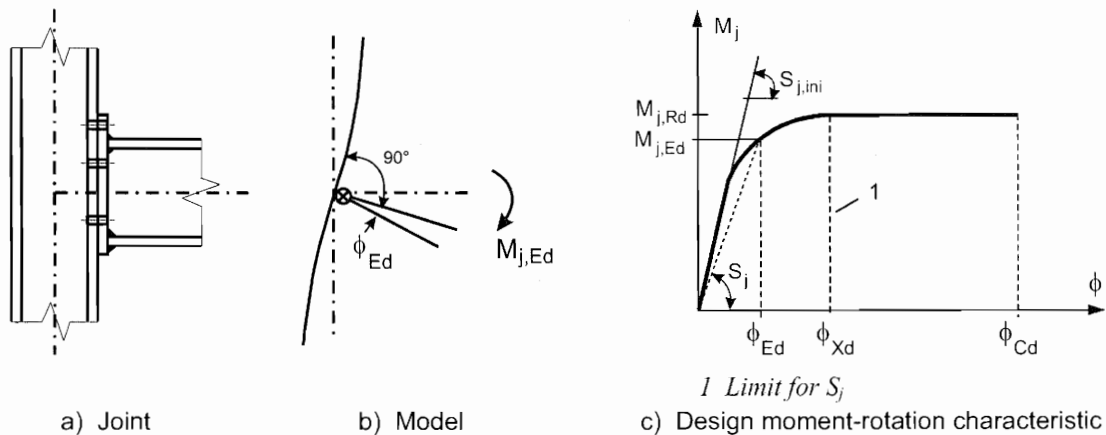


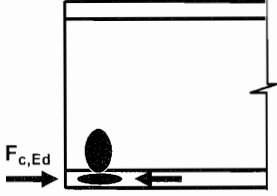
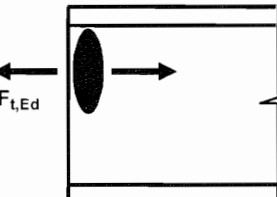
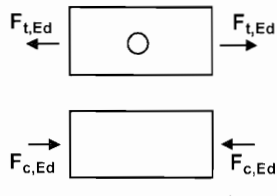
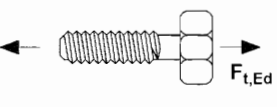
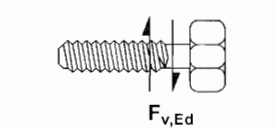
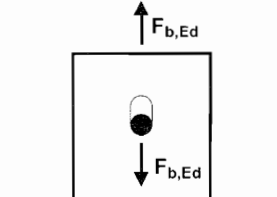
Figure 6.1: Design moment-rotation characteristic for a joint

6.1.3 Basic components of a joint

- (1) The design moment-rotation characteristic of a joint should depend on the properties of its basic components, which should be among those identified in 6.1.3(2).
- (2) The basic joint components should be those identified in Table 6.1, together with the reference to the application rules which should be used for the evaluation of their structural properties.
- (3) Certain joint components may be reinforced. Details of the different methods of reinforcement are given in 6.2.4.3 and 6.2.6.
- (4) The relationships between the properties of the basic components of a joint and the structural properties of the joint should be those given in the following clauses:
- for moment resistance in 6.2.7 and 6.2.8;
 - for rotational stiffness in 6.3.1;
 - for rotation capacity in 6.4.

Table 6.1: Basic joint components

Component			Reference to application rules		
			Design Resistance	Stiffness coefficient	Rotation capacity
1	Column web panel in shear		6.2.6.1	6.3.2	6.4.2 and 6.4.3
2	Column web in transverse compression		6.2.6.2	6.3.2	6.4.2 and 6.4.3
3	Column web in transverse tension		6.2.6.3	6.3.2	6.4.2 and 6.4.3
4	Column flange in bending		6.2.6.4	6.3.2	6.4.2 and 6.4.3
5	End-plate in bending		6.2.6.5	6.3.2	6.4.2
6	Flange cleat in bending		6.2.6.6	6.3.2	6.4.2

Component			Reference to application rules		
			Design Resistance	Stiffness coefficient	Rotation capacity
7	Beam or column flange and web in compression		6.2.6.7	6.3.2	*)
8	Beam web in tension		6.2.6.8	6.3.2	*)
9	Plate in tension or compression		in tension: - EN 1993-1-1 in compression: - EN 1993-1-1	6.3.2	*)
10	Bolts in tension		With column flange: - 6.2.6.4 with end-plate: - 6.2.6.5 with flange cleat: - 6.2.6.6	6.3.2	AC2 6.4.2 AC2
11	Bolts in shear		3.6	6.3.2	6.4.2
12	Bolts in bearing (on beam flange, column flange, end-plate or cleat)		3.6	6.3.2	*)
*) No information available in this part.					

Component		Reference to application rules		
		Design Resistance	Stiffness coefficient	Rotation capacity
13	Concrete in compression including grout	6.2.6.9	6.3.2	*)
14	Base plate in bending under compression	6.2.6.10	6.3.2	*)
15	Base plate in bending under tension	6.2.6.11	6.3.2	*)
16	Anchor bolts in tension	6.2.6.12	6.3.2	*)
17	Anchor bolts in shear	6.2.2	*)	*)
18	Anchor bolts in bearing	6.2.2	*)	*)
19	Welds	4	6.3.2	*)
20	Haunched beam	6.2.6.7	6.3.2	*)

The diagram shows a cross-section of a haunched beam. A vertical downward arrow is applied to the top flange. At the bottom left corner, there are two horizontal arrows pointing outwards, representing reactions. A vertical upward arrow is shown at the bottom center of the beam, likely representing a support reaction or a specific internal force.

*) No information available in this part.

6.2 Design Resistance

6.2.1 Internal forces

- (1) The stresses due to the internal forces and moments in a member may be assumed not to affect the design resistances of the basic components of a joint, except as specified in 6.2.1(2) and 6.2.1(3).
- (2) The longitudinal stress in a column should be taken into account when determining the design resistance of the column web in compression, see 6.2.6.2(2).
- (3) The shear in a column web panel should be taken into account when determining the design resistance of the following basic components:
 - column web in transverse compression, see 6.2.6.2;
 - column web in transverse tension, see 6.2.6.3.

6.2.2 Shear forces

- (1) In welded connections, and in bolted connections with end-plates, the welds connecting the beam web should be designed to transfer the shear force from the connected beam to the joint, without any assistance from the welds connecting the beam flanges.
- (2) In bolted connections with end-plates, the design resistance of each bolt-row to combined shear and tension should be verified using the criterion given in Table 3.4, taking into account the total tensile force in the bolt, including any force due to prying action.

NOTE: As a simplification, bolts required to resist in tension may be assumed to provide their full design resistance in tension when it can be shown that the design shear force does not exceed the sum of:

- a) the total design shear resistance of those bolts that are not required to resist tension and;
 - b) (0,4/1,4) times the total design shear resistance of those bolts that are also required to resist tension.
- (3) In bolted connections with angle flange cleats, the cleat connecting the compression flange of the beam may be assumed to transfer the shear force in the beam to the column, provided that:
 - the gap g between the end of the beam and the face of the column does not exceed the thickness t_a of the angle cleat;
 - the force does not exceed the design shear resistance of the bolts connecting the cleat to the column;
 - the web of the beam satisfies the requirement given in EN 1993-1-5, section 6.
 - (4) The design shear resistance of a joint may be derived from the distribution of internal forces within that joint, and the design resistances of its basic components to these forces, see Table 6.1.
 - (5) In base plates if no special elements for resisting shear are provided, such as block or bar shear connectors, it should be demonstrated $\overline{AC_2}$ that the design friction resistance of the base plate, see 6.2.2(6), and, in cases where the bolt holes are not oversized, the design shear resistance of the anchor bolts, see 6.2.2(7), added up is sufficient $\overline{AC_2}$ to transfer the design shear force. The design bearing resistance of the block or bar shear connectors with respect to the concrete should be checked according to EN 1992.
 - (6) In a column base the design friction resistance $F_{f,Rd}$ between base plate and grout should be derived as follows:

$$F_{f,Rd} = C_{f,d} N_{c,Ed} \quad \dots (6.1)$$

where:

$C_{f,d}$ is the coefficient of friction between base plate and grout layer. The following values may be used:

- for sand-cement mortar $C_{f,d} = 0,20$;
- for other types of grout the coefficient of friction $C_{f,d}$ should be determined by testing in accordance with EN 1990, Annex D;

$N_{c,Ed}$ is the design value of the normal compressive force in the column.

NOTE: If the column is loaded by a tensile normal force, $F_{i,Rd} = 0$.

- (7) In a column base the design shear resistance of an anchor bolt $F_{vb,Rd}$ should be taken as the smaller of $F_{1,vb,Rd}$ and $F_{2,vb,Rd}$ where:

- $F_{1,vb,Rd}$ is the design shear resistance of the anchor bolt, see 3.6.1

$$\boxed{\text{AC2}} - F_{2,vb,Rd} = \frac{\alpha_{bc} f_{ub} A_s}{\gamma_{M2}} \quad \boxed{\text{AC2}} \quad \dots (6.2)$$

where:

$$\alpha_b = 0,44 - 0,0003 f_{yb}$$

f_{yb} is the yield strength of the anchor bolt, where $235 \text{ N/mm}^2 \leq f_{yb} \leq 640 \text{ N/mm}^2$

- (8) $\boxed{\text{AC2}}$ The design shear resistance $F_{v,Rd}$ between a column base plate and a grout layer $\boxed{\text{AC2}}$ should be derived as follows:

$$F_{v,Rd} = F_{f,Rd} + n F_{vb,Rd} \quad \dots (6.3)$$

where:

n is the number of anchor bolts in the base plate.

- (9) The concrete and reinforcement used in the base should be designed in accordance with EN 1992.

6.2.3 Bending moments

- (1) The design moment resistance of any joint may be derived from the distribution of internal forces within that joint and the design resistances of its basic components to these forces, see Table 6.1.

- (2) Provided that the axial force N_{Ed} in the connected member does not exceed 5% of the design resistance $N_{pt,Rd}$ of its cross-section, the design moment resistance $M_{j,Rd}$ of a beam-to-column joint or beam splice may be determined using the method given in 6.2.7.

- (3) The design moment resistance $M_{j,Rd}$ of a column base may be determined using the method given in 6.2.8.

- (4) In all joints, the sizes of the welds should be such that the design moment resistance of the joint $M_{j,Rd}$ is always limited by the design resistance of its other basic components, and not by the design resistance of the welds.

- (5) In a beam-to-column joint or beam splice in which a plastic hinge is required to form and rotate under any relevant load case, the welds should be designed to resist the effects of a moment at least equal to the smaller of:

- the design plastic moment resistance of the connected member $M_{pt,Rd}$
- α times the design moment resistance of the joint $M_{j,Rd}$

where:

$\alpha = 1,4$ - for frames in which the bracing system satisfies the criterion (5.1) in EN 1993-1-1 clause 5.2.1(3) with respect to sway;

$\alpha = 1,7$ - for all other cases.

- (6) In a bolted connection with more than one bolt-row in tension, as a simplification the contribution of any bolt-row may be neglected, provided that the contributions of all other bolt-rows closer to the centre of compression are also neglected.

6.2.4 Equivalent T-stub in tension

6.2.4.1 General

- (1) In bolted connections an equivalent T-stub in tension may be used to model the design resistance of the following basic components:
- column flange in bending;
 - end-plate in bending;
 - flange cleat in bending;
 - base plate in bending under tension.
- (2) Methods for modelling these basic components as equivalent T-stub flanges, including the values to be used for e_{\min} , ℓ_{eff} and m , are given in 6.2.6.
- (3) The possible modes of failure of the flange of an equivalent T-stub may be assumed to be similar to those expected to occur in the basic component that it represents.
- (4) The total effective length $\sum \ell_{\text{eff}}$ of an equivalent T-stub, see Figure 6.2, should be such that the design resistance of its flange is equivalent to that of the basic joint component that it represents.

NOTE: The effective length of an equivalent T-stub is a notional length and does not necessarily correspond to the physical length of the basic joint component that it represents.

- (5) The design tension resistance of a T-stub flange should be determined from Table 6.2.

NOTE: Prying effects are implicitly taken into account when determining the design tension resistance according to Table 6.2.

- (6) In cases where prying forces may develop, see Table 6.2, the design tension resistance of a T-stub flange $F_{T,Rd}$ should be taken as the smallest value for the three possible failure modes 1, 2 and 3.
- (7) In cases where prying forces may not develop the design tension resistance of a T-stub flange $F_{T,Rd}$ should be taken as the smallest value for the two possible failure modes according to Table 6.2.

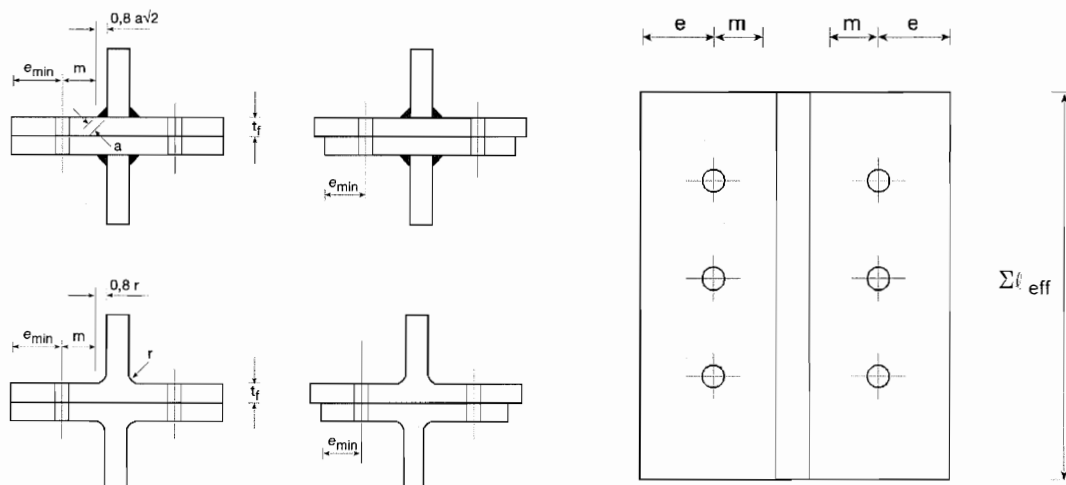


Figure 6.2: Dimensions of an equivalent T-stub flange

Table 6.2: Design Resistance $F_{T,Rd}$ of a T-stub flange

	Prying forces may develop, i.e. $L_b \leq L_b^*$		No prying forces
Mode 1	Method 1	Method 2 (alternative method)	$F_{T,1-2,Rd} = \frac{2M_{pl,1,Rd}}{m}$
without backing plates	$F_{T,1,Rd} = \frac{4M_{pl,1,Rd}}{m}$	$F_{T,1,Rd} = \frac{(8n - 2e_w)M_{pl,1,Rd}}{2mn - e_w(m+n)}$	
with backing plates	$F_{T,1,Rd} = \frac{4M_{pl,1,Rd} + 2M_{bp,Rd}}{m}$	$F_{T,1,Rd} = \frac{(8n - 2e_w)M_{pl,1,Rd} + 4nM_{bp,Rd}}{2mn - e_w(m+n)}$	
Mode 2	$F_{T,2,Rd} = \frac{2M_{pl,2,Rd} + n\Sigma F_{t,Rd}}{m+n}$		
Mode 3	$F_{T,3,Rd} = \Sigma F_{t,Rd}$		

Mode 1: Complete yielding of the flange

Mode 2: Bolt failure with yielding of the flange

Mode 3: Bolt failure

L_b is - the bolt elongation length, taken equal to the grip length (total thickness of material and washers), plus half the sum of the height of the bolt head and the height of the nut or
- the anchor bolt elongation length, taken equal to the sum of 8 times the nominal bolt diameter, the grout layer, the plate thickness, the washer and half the height of the nut

$$\text{AC2} \rangle L_b^* = \frac{8,8m^3 A_s n_b}{\Sigma \ell_{eff,i} t_f^3} \text{AC2} \langle$$

$F_{T,Rd}$ is the design tension resistance of a T-stub flange

Q is the prying force

$$M_{pl,1,Rd} = 0,25 \Sigma \ell_{eff,1} t_f^2 f_y / \gamma_{M0}$$

$$M_{pl,2,Rd} = 0,25 \Sigma \ell_{eff,2} t_f^2 f_y / \gamma_{M0}$$

$$M_{bp,Rd} = 0,25 \Sigma \ell_{eff,1} t_{bp}^2 f_{y,bp} / \gamma_{M0}$$

$$n = e_{min} \quad \text{but} \quad n \leq 1,25m$$

$\text{AC2} \rangle n_b$ is the number of bolt rows (with 2 bolts per row) $\text{AC2} \langle$

$F_{t,Rd}$ is the design tension resistance of a bolt, see Table 3.4;

$\Sigma F_{t,Rd}$ is the total value of $F_{t,Rd}$ for all the bolts in the T-stub;

$\Sigma \ell_{eff,1}$ is the value of $\Sigma \ell_{eff}$ for mode 1;

$\Sigma \ell_{eff,2}$ is the value of $\Sigma \ell_{eff}$ for mode 2;

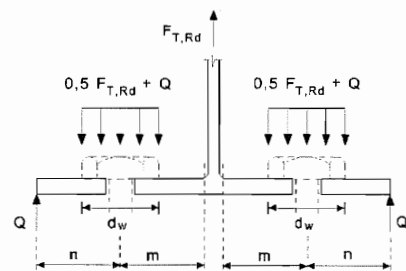
e_{min} , m and t_f are as indicated in Figure 6.2.

$f_{y,bp}$ is the yield strength of the backing plates;

t_{bp} is the thickness of the backing plates;

$$e_w = d_w / 4;$$

d_w is the diameter of the washer, or the width across points of the bolt head or nut, as relevant.



NOTE 1: In bolted beam-to-column joints or beam splices it may be assumed that prying forces will develop.

NOTE 2: In method 2, the force applied to the T-stub flange by a bolt is assumed to be uniformly distributed under the washer, the bolt head or the nut, as appropriate, see figure, instead of concentrated at the centre-line of the bolt. This assumption leads to a higher value for mode 1, but leaves the values for $F_{T,1-2,Rd}$ and modes 2 and 3 unchanged.

6.2.4.2 Individual bolt-rows, bolt-groups and groups of bolt-rows

- (1) Although in an actual T-stub flange the forces at each bolt-row are generally equal, when an equivalent T-stub flange is used to model a basic component listed in 6.2.4.1(1), allowance should be made for the different in forces at each bolt-row.
- (2) When using the equivalent T-stub approach to model a group of bolt rows it may be necessary to divide the group into separate bolt-rows and use an equivalent T-stub to model each separate bolt-row.
- (3) When using the T-stub approach to model a group of bolt rows the following conditions should be satisfied:
 - a) the force at each bolt-row should not exceed the design resistance determined considering only that individual bolt-row;
 - b) the total force on each group of bolt-rows, comprising two or more adjacent bolt-rows within the same bolt-group, should not exceed the design resistance of that group of bolt-rows.
- (4) When determining the design tension resistance of a basic component represented by an equivalent T-stub flange, the following parameters should be calculated:
 - a) the design resistance of an individual bolt-row, determined considering only that bolt-row;
 - b) the contribution of each bolt-row to the design resistance of two or more adjacent bolt-rows within a bolt-group, determined considering only those bolt-rows.
- (5) In the case of an individual bolt-row $\sum \ell_{\text{eff}}$ should be taken as equal to the effective length ℓ_{eff} tabulated in 6.2.6 for that bolt-row taken as an individual bolt-row.
- (6) In the case of a group of bolt-rows $\sum \ell_{\text{eff}}$ should be taken as the sum of the effective lengths ℓ_{eff} tabulated in 6.2.6 for each relevant bolt-row taken as part of a bolt-group.

6.2.4.3 Backing plates

- (1) Backing plates may be used to reinforce a column flange in bending as indicated in Figure 6.3.
- (2) Each backing plate should extend at least to the edge of the column flange, and to within 3 mm of the toe of the root radius or of the weld.
- (3) The backing plate should extend beyond the furthest bolt rows active in tension as defined in Figure 6.3.
- (4) Where backing plates are used, the design resistance of the T-stub $F_{T,Rd}$ should be determined using the method given in Table 6.2.

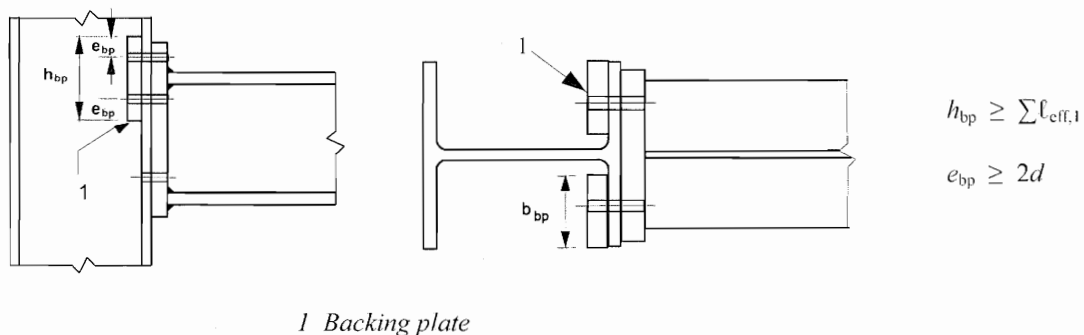


Figure 6.3: Column flange with backing plates

6.2.5 Equivalent T-stub in compression

- (1) In steel-to-concrete joints, the flange of an equivalent T-stub in compression may be used to model the design resistances for the combination of the following basic components:
 - the steel base plate in bending under the bearing pressure on the foundation;
 - the concrete and/or grout joint material in bearing.
- (2) The total effective length l_{eff} and the total effective width b_{eff} of an equivalent T-stub should be such that the design compression resistance of the T-stub is equivalent to that of the basic joint component it represents.

NOTE: $\langle \text{AC}_2 \rangle$ The values for the effective length and the effective width of an equivalent T-stub are notional values for these lengths $\langle \text{AC}_2 \rangle$ and may differ to the physical dimensions of the basic joint component it represents.

- (3) The design compression resistance of a T-stub flange $F_{\text{C,Rd}}$ should be determined as follows:

$$F_{\text{C,Rd}} = f_{\text{jd}} b_{\text{eff}} l_{\text{eff}} \quad \dots (6.4)$$

where:

b_{eff} is the effective width of the T-stub flange, see 6.2.5(5) and 6.2.5(6)

l_{eff} is the effective length of the T-stub flange, see 6.2.5(5) and 6.2.5(6)

f_{jd} is the design bearing strength of the joint, see 6.2.5(7)

- (4) The forces transferred through a T-stub should be assumed to spread uniformly as shown in Figure 6.4(a) and (b). The pressure on the resulting bearing area should not exceed the design bearing strength f_{jd} and the additional bearing width, c , should not exceed:

$$c = t [f_y / (3 f_{\text{jd}} \gamma_{\text{M0}})]^{0.5} \quad \dots (6.5)$$

where:

t is the thickness of the T-stub flange;

f_y is the yield strength of the T-stub flange.

- (5) Where the projection of the physical length of the basic joint component represented by the T-stub is less than c , the effective area should be taken as indicated in Figure 6.4(a)
- (6) Where the projection of the physical length of the basic joint component represented by the T-stub exceeds c on any side, the part of the additional projection beyond the width c should be neglected, see Figure 6.4(b).

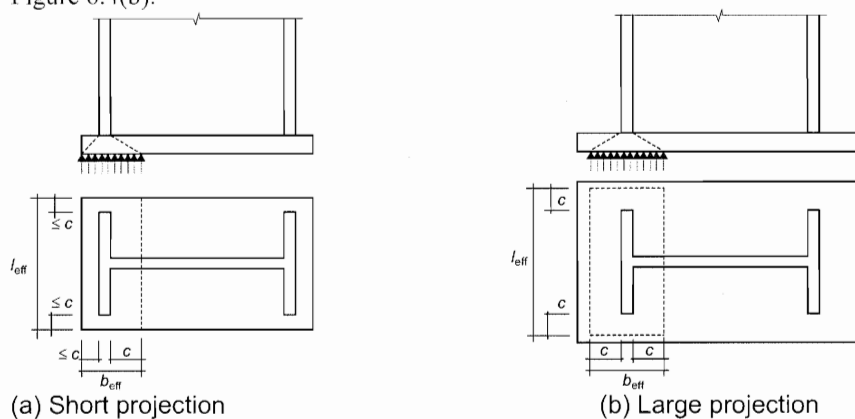


Figure 6.4: Area of equivalent T-Stub in compression

- (7) The design bearing strength of the joint f_{jd} should be determined from:

$$f_{jd} = \beta_j F_{Rdu} / (b_{eff} l_{eff}) \quad \dots (6.6)$$

where:

β_j is the foundation joint material coefficient, which may be taken as 2/3 provided that the characteristic strength of the grout is not less than 0,2 times the characteristic strength of the concrete foundation and the thickness of the grout is not greater than 0,2 times the smallest width of the steel base plate. In cases where the thickness of the grout is more than 50 mm, the characteristic strength of the grout should be at least the same as that of the concrete foundation.

F_{Rdu} is the concentrated design resistance force given in EN 1992, where A_{c0} is to be taken as $(b_{eff} l_{eff})$.

6.2.6 Design Resistance of basic components

6.2.6.1 Column web panel in shear

- (1) The design methods given in 6.2.6.1(2) to 6.2.6.1(14) are valid provided the column web slenderness satisfies the condition $\frac{d_c/t_w}{\sqrt{A_{C2}}} \leq 69 \varepsilon \sqrt{A_{C2}}$.
- (2) For a single-sided joint, or for a double-sided joint in which the beam depths are similar, the design plastic shear resistance $V_{wp,Rd}$ of an unstiffened column web panel, subject to a design shear force $V_{wp,Ed}$, see 5.3(3), should be obtained using:

$$V_{wp,Rd} = \frac{0,9 f_{y,wc} A_{vc}}{\sqrt{3} \gamma_{M0}} \quad \dots (6.7)$$

where:

A_{vc} is the shear area of the column, see EN 1993-1-1.

- (3) The design shear resistance may be increased by the use of stiffeners or supplementary web plates.
- (4) Where transverse web stiffeners are used in both the compression zone and the tension zone, the design plastic shear resistance of the column web panel $V_{wp,Rd}$ may be increased by $V_{wp,add,Rd}$ given by:

$$V_{wp,add,Rd} = \frac{4M_{pl,fc,Rd}}{d_s} \quad \text{but} \quad V_{wp,add,Rd} \leq \frac{2M_{pl,fc,Rd} + 2M_{pl,st,Rd}}{d_s} \quad \dots (6.8)$$

where:

d_s is the distance between the centrelines of the stiffeners;

$M_{pl,fc,Rd}$ is the design plastic moment resistance of a column flange

$M_{pl,st,Rd}$ is the design plastic moment resistance of a stiffener.

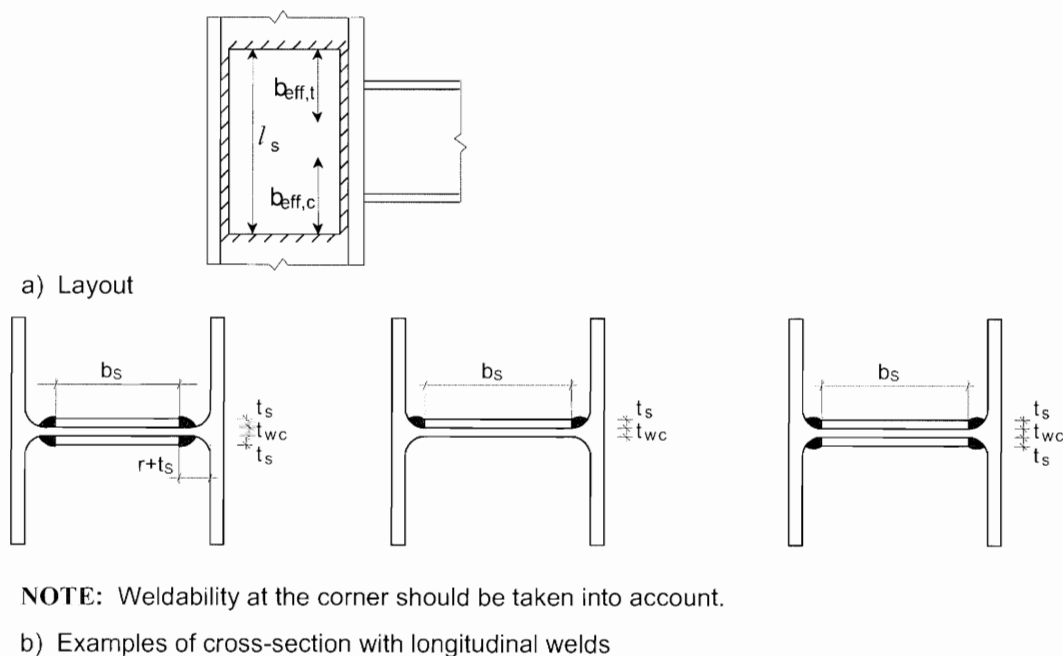
NOTE: In welded joints, the transverse stiffeners should be aligned with the corresponding beam flange.

- (5) When diagonal web stiffeners are used the design plastic shear resistance of a column web should be determined according to EN 1993-1-1.

NOTE: In double-sided beam-to-column joint configurations without diagonal stiffeners on the column webs, the two beams are assumed to have similar depths.

- (6) Where a column web is reinforced by adding a supplementary web plate, see Figure 6.5, the shear area A_{vc} may be increased by $b_s t_{wc}$. If a further supplementary web plate is added on the other side of the web, no further increase of the shear area should be made.

- (7) Supplementary web plates may also be used to increase the rotational stiffness of a joint by increasing the stiffness of the column web in shear, compression or tension, see 6.3.2(1).
- (8) The steel grade of the supplementary web plate should be equal to that of the column.
- (9) The width b_s should be such that the supplementary web plate extends at least to the toe of the root radius or of the weld.
- (10) The length l_s should be such that the supplementary web plate extends throughout the effective width of the web in tension and compression, see Figure 6.5.
- (11) The thickness t_s of the supplementary web plate should be not less than the column web thickness t_{wc} .
- (12) The welds between the supplementary web plate and profile should be designed to resist the applied design forces.
- (13) The width b_s of a supplementary web plate should be less than $40\epsilon t_s$.
- (14) Discontinuous welds may be used in non corrosive environments.



NOTE: Weldability at the corner should be taken into account.

Figure 6.5: Examples of supplementary web plates

6.2.6.2 Column web in transverse compression

- (1) The design resistance of an unstiffened column web subject to transverse compression should be determined from:

$$F_{c,wc,Rd} = \frac{\omega k_{wc} b_{eff,c,wc} t_{wc} f_{y,wc}}{\gamma_{M0}} \quad \text{but} \quad F_{c,wc,Rd} \leq \frac{\omega k_{wc} \rho b_{eff,c,wc} t_{wc} f_{y,wc}}{\gamma_{M1}} \quad \dots (6.9)$$

where:

ω is a reduction factor to allow for the possible effects of interaction with shear in the column web panel according to Table 6.3;

$b_{\text{eff},c,\text{wc}}$ is the effective width of column web in compression:

– for a welded connection:

$$b_{\text{eff},c,\text{wc}} = t_{fb} + 2\sqrt{2} a_b + 5(t_{fc} + s) \quad \dots (6.10)$$

a_c , r_c and a_b are as indicated in Figure 6.6.

– for bolted end-plate connection:

$$b_{\text{eff},c,\text{wc}} = t_{fb} + 2\sqrt{2} a_p + 5(t_{fc} + s) + s_p \quad \dots (6.11)$$

s_p is the length obtained by dispersion at 45° through the end-plate (at least t_p and, provided that the length of end-plate below the flange is sufficient, up to $2t_p$).

– for bolted connection with angle flange cleats:

$$b_{\text{eff},c,\text{wc}} = 2t_a + 0,6r_a + 5(t_{fc} + s) \quad \dots (6.12)$$

– for a rolled I or H section column: $s = r_c$

– for a welded I or H section column: $s = \sqrt{2}a_c$

ρ is the reduction factor for plate buckling:

– if $\bar{\lambda}_p \leq 0,72$: $\rho = 1,0$... (6.13a)

– if $\bar{\lambda}_p > 0,72$: $\rho = (\bar{\lambda}_p - 0,2) / \bar{\lambda}_p^2$... (6.13b)

$\bar{\lambda}_p$ is the plate slenderness:

$$\bar{\lambda}_p = 0,932 \sqrt{\frac{b_{\text{eff},c,\text{wc}} d_{\text{wc}} f_{y,\text{wc}}}{Et_{\text{wc}}^2}} \quad \dots (6.13c)$$

– for a rolled I or H section column: $d_{\text{wc}} = h_c - 2(t_{fc} + r_c)$

– for a welded I or H section column: $d_{\text{wc}} = h_c - 2(t_{fc} + \sqrt{2}a_c)$

k_{wc} is a reduction factor and is given in 6.2.6.2(2).

Table 6.3: Reduction factor ω for interaction with shear

Transformation parameter β	Reduction factor ω
$0 \leq \beta \leq 0,5$	$\omega = 1$
$0,5 < \beta < 1$	$\omega = \omega_1 + 2(1 - \beta)(1 - \omega_1)$
$\beta = 1$	$\omega = \omega_1$
$1 < \beta < 2$	$\omega = \omega_1 + (\beta - 1)(\omega_2 - \omega_1)$
$\beta = 2$	$\omega = \omega_2$
$\omega_1 = \frac{1}{\sqrt{1 + 1,3(b_{\text{eff},c,\text{wc}} t_{\text{wc}} / A_{\text{vc}})^2}}$	$\omega_2 = \frac{1}{\sqrt{1 + 5,2(b_{\text{eff},c,\text{wc}} t_{\text{wc}} / A_{\text{vc}})^2}}$
A_{vc} is the shear area of the column, see 6.2.6.1;	
β is the transformation parameter, see 5.3(7).	

- (2) Where the maximum longitudinal compressive stress $\sigma_{com,Ed}$ due to axial force and bending moment in the column exceeds $0,7f_{y,wc}$ in the web (adjacent to the root radius for a rolled section or the toe of the weld for a welded section), its effect on the design resistance of the column web in compression should be allowed for by multiplying the value of $F_{c,wc,Rd}$ given by expression (6.9) by a reduction factor k_{wc} as follows:

- when $\sigma_{com,Ed} \leq 0,7f_{y,wc}$: $k_{wc} = 1$
- when $\sigma_{com,Ed} > 0,7f_{y,wc}$: $k_{wc} = 1,7 - \sigma_{com,Ed} / f_{y,wc}$... (6.14)

NOTE: Generally the reduction factor k_{wc} is 1,0 and no reduction is necessary. It can therefore be omitted in preliminary calculations when the longitudinal stress is unknown and checked later.

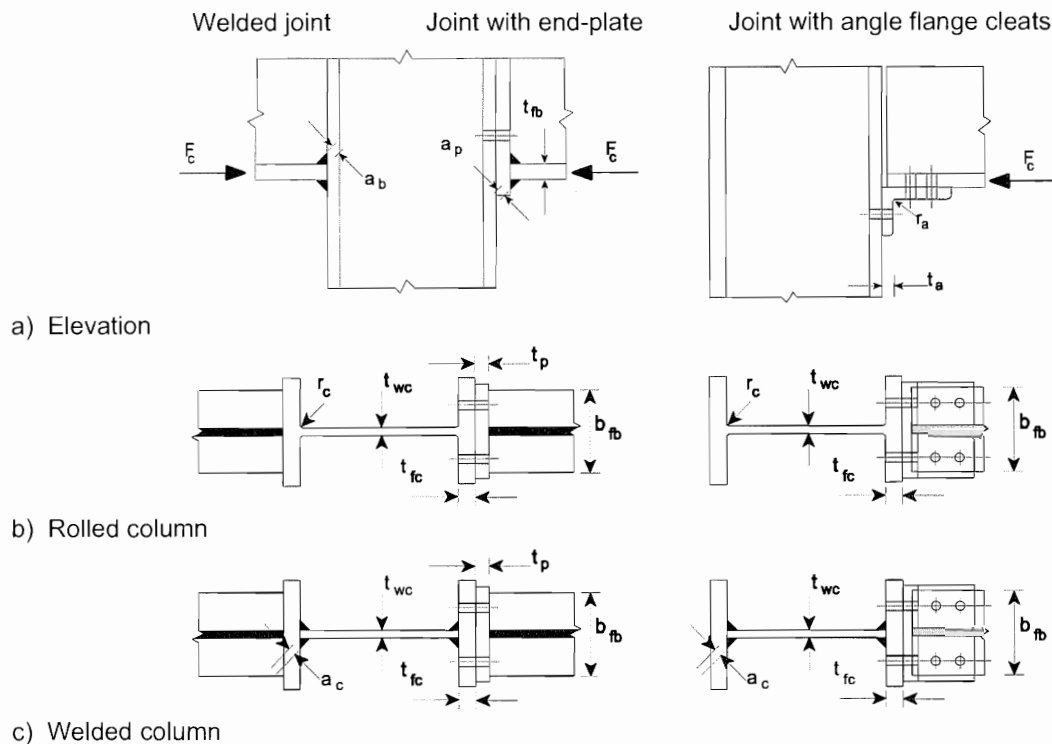


Figure 6.6: Transverse compression on an unstiffened column

- (3) The 'column-sway' buckling mode of an unstiffened column web in compression illustrated in Figure 6.7 should normally be prevented by constructional restraints.

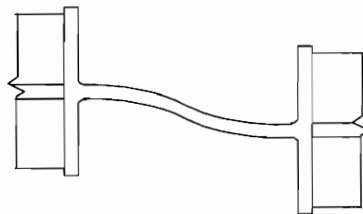


Figure 6.7: 'Column-sway' buckling mode of an unstiffened web

- (4) Stiffeners or supplementary web plates may be used to increase the design resistance of a column web in transverse compression.

- (5) Transverse stiffeners or appropriate arrangements of diagonal stiffeners may be used (in association with or as an alternative to transverse stiffeners) in order to increase the design resistance of the column web in compression.

NOTE: In welded joints, the transverse stiffeners should be aligned with the corresponding beam flange. In bolted joints, the stiffener in the compression zone should be aligned with the centre of compression as defined Figure 6.15.

- (6) Where an unstiffened column web is reinforced by adding a supplementary web plate conforming with 6.2.6.1, the effective thickness of the web may be taken as $1,5 t_{wc}$ if one supplementary web plate is added, or $2,0 t_{wc}$ if supplementary web plates are added to both sides of the web. In calculating the reduction factor ω for the possible effects of shear stress, the shear area A_{vc} of the web may be increased only to the extent permitted when determining its design shear resistance, see 6.2.6.1(6).

6.2.6.3 Column web in transverse tension

- (1) The design resistance of an unstiffened column web subject to transverse tension should be determined from:

$$F_{t,wc,Rd} = \frac{\omega b_{eff,t,wc} t_{wc} f_{y,wc}}{\gamma_{M0}} \quad \dots (6.15)$$

where:

ω is a reduction factor to allow for the interaction with shear in the column web panel.

- (2) For a welded connection, the effective width $b_{eff,t,wc}$ of a column web in tension should be obtained using:

$$b_{eff,t,wc} = t_{fb} + 2\sqrt{2} a_b + 5(t_{fc} + s) \quad \dots (6.16)$$

where:

- for a rolled I or H section column: $s = r_c$
- for a welded I or H section column: $s = \sqrt{2} a_c$

where:

a_c and r_c are as indicated in Figure 6.8 and a_b is as indicated in Figure 6.6.

- (3) For a bolted connection, the effective width $b_{eff,t,wc}$ of column web in tension should be taken as equal to the effective length of equivalent T-stub representing the column flange, see 6.2.6.4.
- (4) The reduction factor ω to allow for the possible effects of shear in the column web panel should be determined from Table 6.3, using the value of $b_{eff,t,wc}$ given in 6.2.6.3(2) or 6.2.6.3(3) as appropriate.
- (5) Stiffeners or supplementary web plates may be used to increase the design tension resistance of a column web.
- (6) Transverse stiffeners and/or appropriate arrangements of diagonal stiffeners may be used to increase the design resistance of the column web in tension.

NOTE: In welded joints, the transverse stiffeners are normally aligned with the corresponding beam flange.

- (7) The welds connecting diagonal stiffeners to the column flange should be fill-in welds with a sealing run providing a combined throat thickness equal to the thickness of the stiffeners.
- (8) Where an unstiffened column web is reinforced by adding supplementary web plates conforming with 6.2.6.1, the design tension resistance depends on the throat thickness of the longitudinal welds connecting the supplementary web plates. The effective thickness of the web $t_{w,eff}$ should be taken as follows:
- when the longitudinal welds are full penetration butt welds with a throat thickness $a \geq t_s$ then:
 - for one supplementary web plate: $t_{w,eff} = 1,5 t_{wc}$... (6.17)
 - for supplementary web plates both sides: $t_{w,eff} = 2,0 t_{wc}$... (6.18)
 - when the longitudinal welds are fillet welds with a throat thickness $a \geq t_s / \sqrt{2}$ then for either one or two supplementary web plates:
 - for steel grades S 235, S 275 or S 355: $t_{w,eff} = 1,4 t_{wc}$... (6.19a)
 - for steel grades S 420 or S 460: $t_{w,eff} = 1,3 t_{wc}$... (6.19b)
- (9) In calculating the reduction factor ω for the possible effects of shear stress, the shear area A_{vc} of a column web reinforced by adding supplementary web plates may be increased only to the extent permitted when determining its design shear resistance, see 6.2.6.1(6).

6.2.6.4 Column flange in transverse bending

6.2.6.4.1 Unstiffened column flange, bolted connection

- (1) The design resistance and failure mode of an unstiffened column flange in transverse bending, together with the associated bolts in tension, should be taken as similar to those of an equivalent T-stub flange, see 6.2.4, for both:
- each individual bolt-row required to resist tension;
 - each group of bolt-rows required to resist tension.
- (2) The dimensions e_{min} and m for use in 6.2.4 should be determined from Figure 6.8.
- (3) The effective length of equivalent T-stub flange should be determined for the individual bolt-rows and the bolt-group in accordance with 6.2.4.2 from the values given for each bolt-row in Table 6.4.

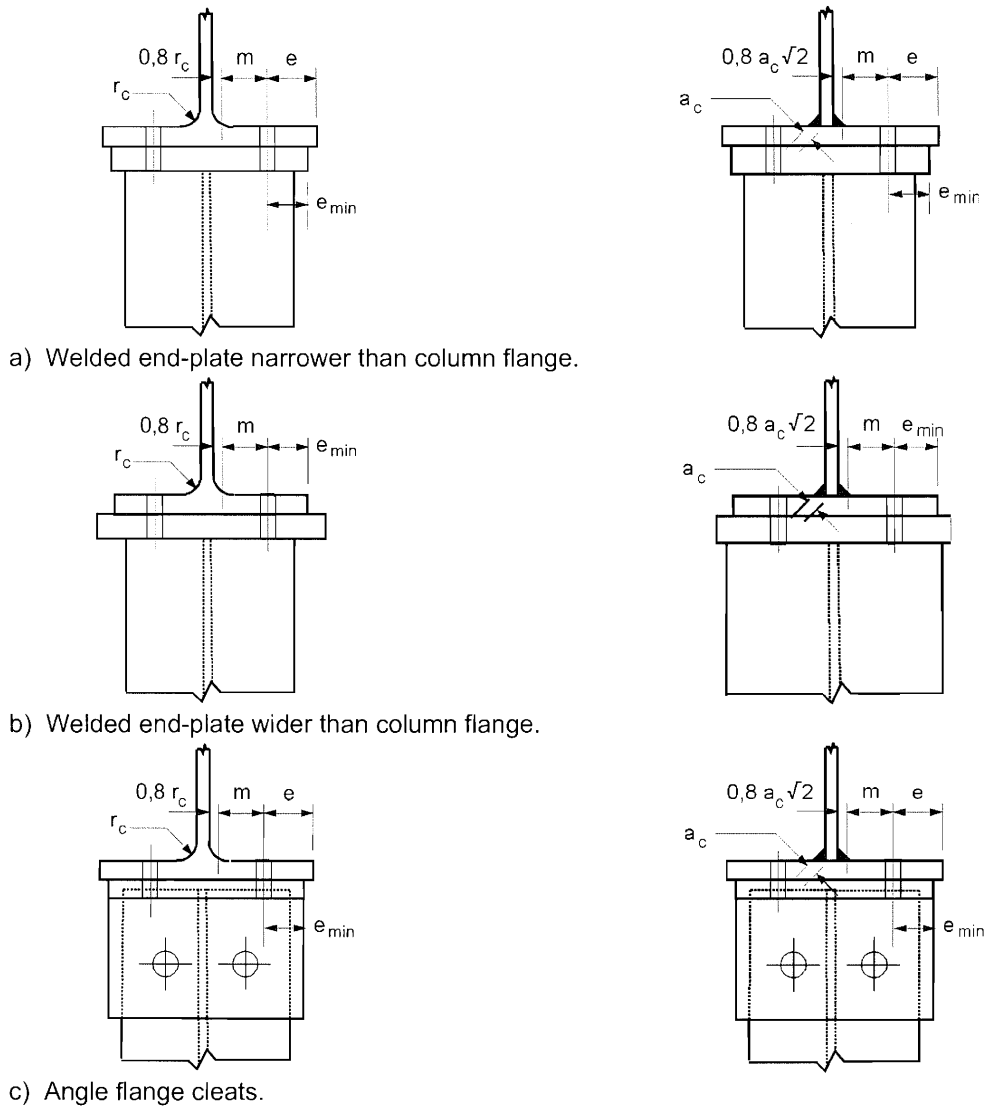


Figure 6.8: Definitions of e , e_{\min} , r_c and m

Table 6.4: Effective lengths for an unstiffened column flange

Bolt-row Location	Bolt-row considered individually		Bolt-row considered as part of a group of bolt-rows	
	Circular patterns $\ell_{\text{eff,ep}}$	Non $\ell_{\text{eff,nc}}$	Circular patterns $\ell_{\text{eff,ep}}$	Non-circular patterns $\ell_{\text{eff,nc}}$
Inner bolt-row	$2\pi m$	$4m + 1,25e$	$2p$	p
End bolt-row	The smaller of: $2\pi m$ $\pi m + 2e_1$	The smaller of: $4m + 1,25e$ $2m + 0,625e + e_1$	The smaller of: $\pi m + p$ $2e_1 + p$	The smaller of: $2m + 0,625e + 0,5p$ $e_1 + 0,5p$
Mode 1:	$\ell_{\text{eff,1}} = \ell_{\text{eff,nc}}$ but $\ell_{\text{eff,1}} \leq \ell_{\text{eff,ep}}$		$\sum \ell_{\text{eff,1}} = \sum \ell_{\text{eff,nc}}$ but $\sum \ell_{\text{eff,1}} \leq \sum \ell_{\text{eff,ep}}$	
Mode 2:	$\ell_{\text{eff,2}} = \ell_{\text{eff,nc}}$		$\sum \ell_{\text{eff,2}} = \sum \ell_{\text{eff,nc}}$	

$\langle AC_2 \rangle$ e_1 is the distance from the centre of the fasteners in the end row to the adjacent free end of the column flange measured in the direction of the axis of the column profile (see row 1 and row 2 in Figure 6.9). $\langle AC_2 \rangle$

6.2.6.4.2 Stiffened column flange, joint with bolted end-plate or flange cleats

- (1) Transverse stiffeners and/or appropriate arrangements of diagonal stiffeners may be used to increase the design resistance of the column flange in bending.
- (2) The design resistance and failure mode of a stiffened column flange in transverse bending, together with the associated bolts in tension, should be taken as similar to those of an equivalent T-stub flange, see 6.2.4, for both:
 - each individual bolt-row required to resist tension;
 - each group of bolt-rows required to resist tension.
- (3) The groups of bolt-rows on either side of a stiffener should be modelled as separate equivalent T-stub flanges, see Figure 6.9. The design resistance and failure mode should be determined separately for each equivalent T-stub.

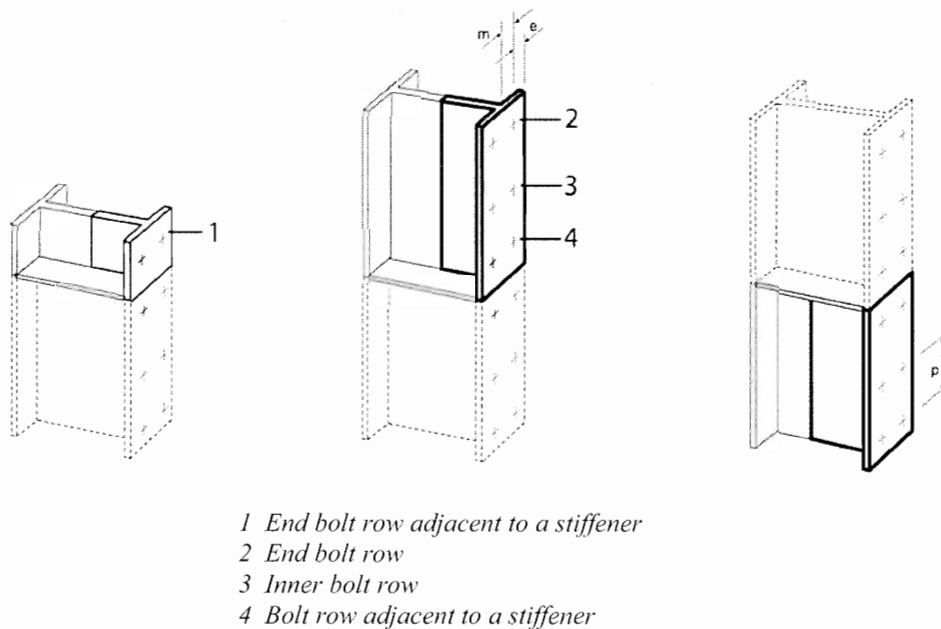


Figure 6.9: Modelling a stiffened column flange as separate T-stubs

- (4) The dimensions e_{\min} and m for use in 6.2.4 should be determined from Figure 6.8.
- (5) The effective lengths of an equivalent T-stub flange l_{eff} should be determined in accordance with 6.2.4.2 using the values for each bolt-row given in Table 6.5. The value of α for use in Table 6.5 should be obtained from Figure 6.11.
- (6) The stiffeners should meet the requirements specified in 6.2.6.1.

Table 6.5: Effective lengths for a stiffened column flange

Bolt-row Location	Bolt-row considered individually		Bolt-row considered as part of a group of bolt-rows	
	Circular patterns $\ell_{\text{eff,cp}}$	Non-circular patterns $\ell_{\text{eff,nc}}$	Circular patterns $\ell_{\text{eff,cp}}$	Non-circular patterns $\ell_{\text{eff,nc}}$
Bolt-row adjacent to a stiffener	$2\pi m$	αm	$\pi m + p$	$0,5p + \alpha m - (2m + 0,625e)$
Other inner bolt-row	$2\pi m$	$4m + 1,25e$	$2p$	p
Other end bolt-row	The smaller of: $2\pi m$ $\pi m + 2e_1$	The smaller of: $4m + 1,25e$ $2m + 0,625e + e_1$	The smaller of: $\pi m + p$ $2e_1 + p$	The smaller of: $2m + 0,625e + 0,5p$ $e_1 + 0,5p$
End bolt-row adjacent to a stiffener	The smaller of: $2\pi m$ $\pi m + 2e_1$	$e_1 + \alpha m - (2m + 0,625e)$	not relevant	not relevant
For Mode 1:	$\ell_{\text{eff},1} = \ell_{\text{eff,nc}}$ but $\ell_{\text{eff},1} \leq \ell_{\text{eff,cp}}$		$\sum \ell_{\text{eff},1} = \sum \ell_{\text{eff,nc}}$ but $\sum \ell_{\text{eff},1} \leq \sum \ell_{\text{eff,cp}}$	
For Mode 2:	$\ell_{\text{eff},2} = \ell_{\text{eff,nc}}$		$\sum \ell_{\text{eff},2} = \sum \ell_{\text{eff,nc}}$	

α should be obtained from Figure 6.11.
 $\langle \text{AC2} \rangle$ e_1 is the distance from the centre of the fasteners in the end row to the adjacent stiffener of the column flange measured in the direction of the axis of the column profile (see row 1 and row 4 in Figure 6.9). $\langle \text{AC2} \rangle$

6.2.6.4.3 Unstiffened column flange, welded connection

- (1) In a welded joint, the design resistance $F_{\text{fc,Rd}}$ of an unstiffened column flange in bending, due to tension or compression from a beam flange, should be obtained using:

$$F_{\text{fc,Rd}} = b_{\text{eff},b,\text{fc}} t_{\text{fb}} f_{\gamma,\text{fb}} / \gamma_{M0} \quad \dots (6.20)$$

where:

$b_{\text{eff},b,\text{fc}}$ is the effective breadth b_{eff} defined in 4.10 where the beam flange is considered as a plate.

NOTE: See also the requirements specified in $\langle \text{AC2} \rangle$ 4.10 $\langle \text{AC2} \rangle$.

6.2.6.5 End-plate in bending

- (1) The design resistance and failure mode of an end-plate in bending, together with the associated bolts in tension, should be taken as similar to those of an equivalent T-stub flange, see 6.2.4 for both:
- each individual bolt-row required to resist tension;
 - each group of bolt-rows required to resist tension.
- (2) The groups of bolt-rows either side of any stiffener connected to the end-plate should be treated as separate equivalent T-stubs. In extended end-plates, the bolt-row in the extended part should also be treated as a separate equivalent T-stub, see Figure 6.10. The design resistance and failure mode should be determined separately for each equivalent T-stub.
- (3) The dimension e_{min} required for use in 6.2.4 should be obtained from Figure 6.8 for that part of the end-plate located between the beam flanges. For the end-plate extension e_{min} should be taken as equal to e_x , see Figure 6.10.
- (4) The effective length of an equivalent T-stub flange ℓ_{eff} should be determined in accordance with 6.2.4.2 using the values for each bolt-row given in Table 6.6.

(5) The values of m and m_x for use in Table 6.6 should be obtained from Figure 6.10.

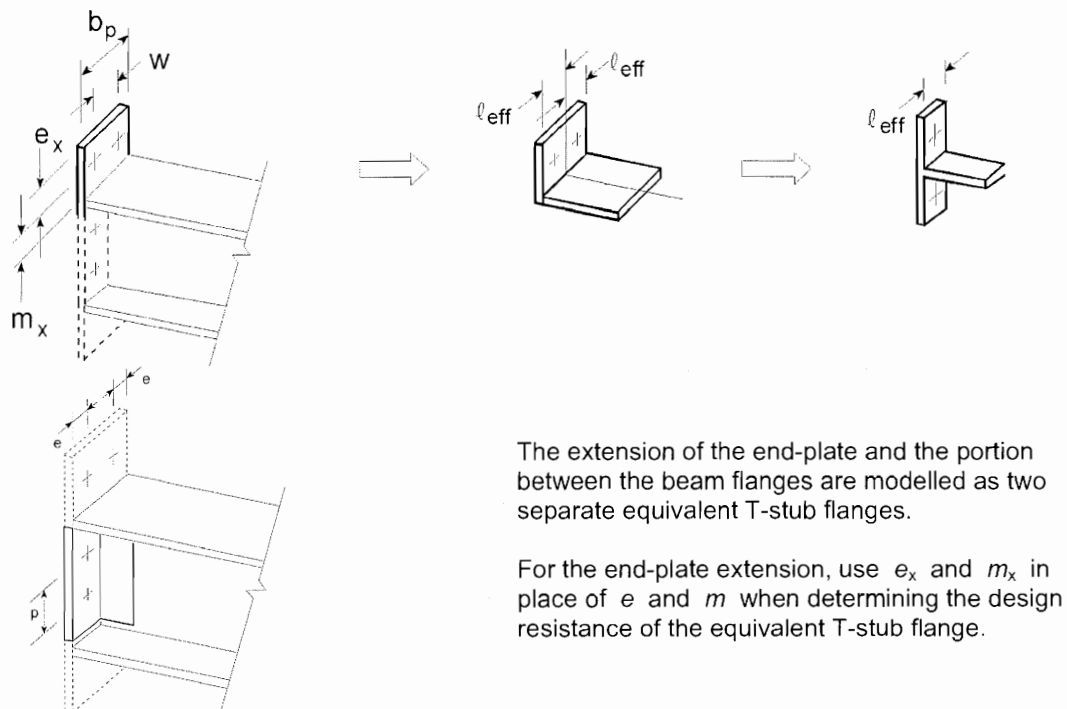


Figure 6.10: Modelling an extended end-plate as separate T-stubs

Table 6.6: Effective lengths for an end-plate

Bolt-row location	Bolt-row considered individually		Bolt-row considered as part of a group of bolt-rows	
	Circular patterns $\ell_{\text{eff,cp}}$	Non-circular patterns $\ell_{\text{eff,nc}}$	Circular patterns $\ell_{\text{eff,cp}}$	Non-circular patterns $\ell_{\text{eff,nc}}$
Bolt-row outside tension flange of beam	Smallest of: $2\pi m_x$ $\pi m_x + w$ $\pi m_x + 2e$	Smallest of: $4m_x + 1,25e_x$ $e + 2m_x + 0,625e_x$ $0,5b_p$ $0,5w + 2m_x + 0,625e_x$	—	—
First bolt-row below tension flange of beam	$2\pi m$	αm	$\pi m + p$	$0,5p + \alpha m - (2m + 0,625e)$
Other inner bolt-row	$2\pi m$	$4m + 1,25e$	$2p$	p
Other end bolt-row	$2\pi m$	$4m + 1,25e$	$\pi m + p$	$2m + 0,625e + 0,5p$
Mode 1:	$\ell_{\text{eff},1} = \ell_{\text{eff,nc}}$ but $\ell_{\text{eff},1} \leq \ell_{\text{eff,cp}}$		$\sum \ell_{\text{eff},1} = \sum \ell_{\text{eff,nc}}$ but $\sum \ell_{\text{eff},1} \leq \sum \ell_{\text{eff,cp}}$	
Mode 2:	$\ell_{\text{eff},2} = \ell_{\text{eff,nc}}$		$\sum \ell_{\text{eff},2} = \sum \ell_{\text{eff,nc}}$	
α should be obtained from Figure 6.11.				

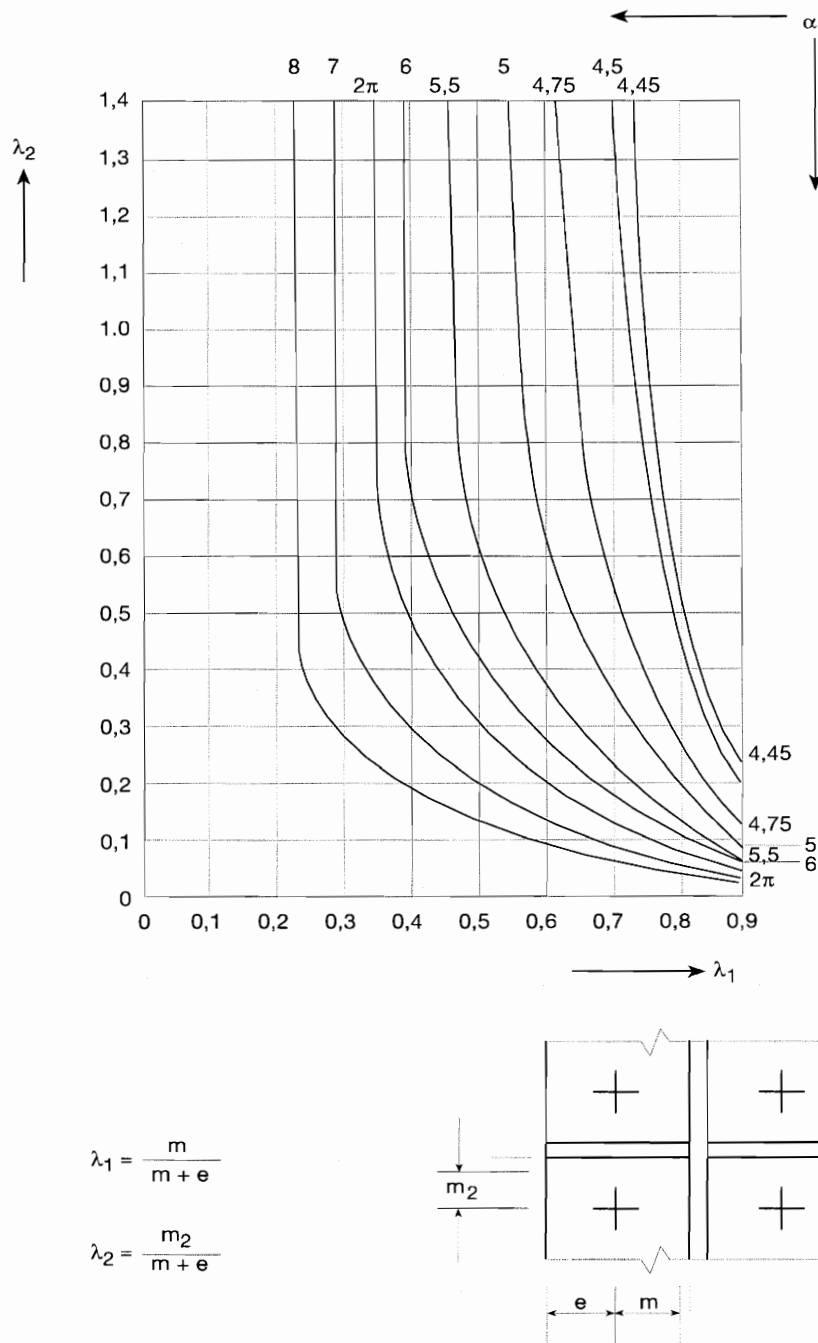


Figure 6.11: Values of α for stiffened column flanges and end-plates

6.2.6.6 Flange cleat in bending

- (1) The design resistance and failure mode of a bolted angle flange cleat in bending, together with the associated bolts in tension, should be taken as similar to those of an equivalent T-stub flange, see 6.2.4.
- (2) The effective length ℓ_{eff} of the equivalent T-stub flange should be taken as $0,5b_a$ where b_a is the length of the angle cleat, see Figure 6.12.

- (3) The dimensions e_{\min} and m for use in 6.2.4 should be determined from Figure 6.13.

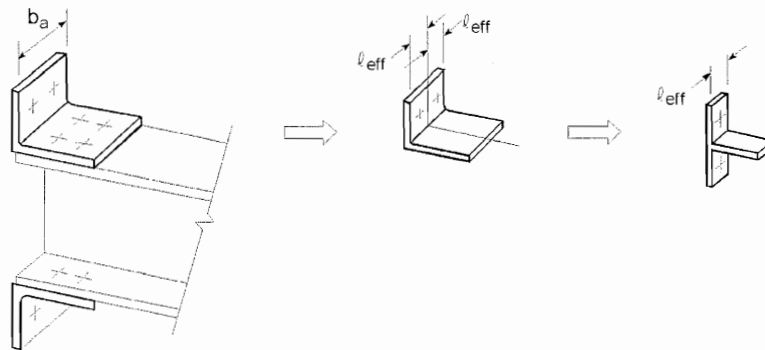
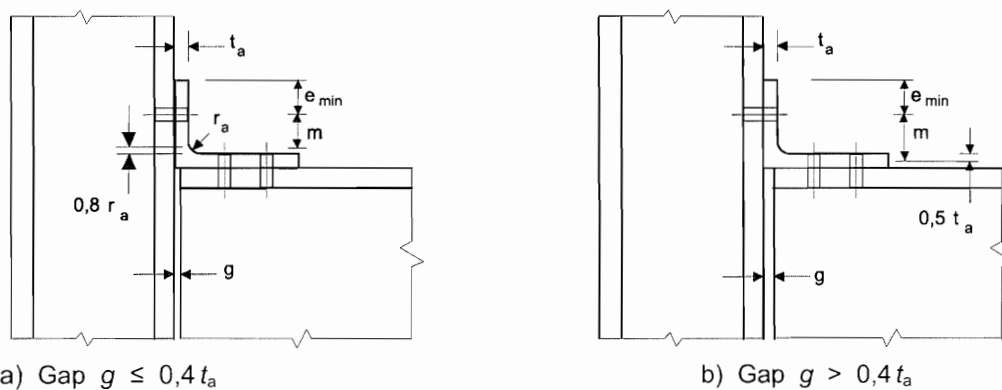


Figure 6.12: Effective length l_{eff} of an angle flange cleat



a) Gap $g \leq 0,4 t_a$

b) Gap $g > 0,4 t_a$

Notes:

- The number of bolt-rows connecting the cleat to the column flange is limited to one;
- The number of bolt-rows connecting the cleat to the beam flange is not limited;
- The length b_a of the cleat may be different from both the width of the beam flange and the width of the column flange.

Figure 6.13: Dimensions e_{\min} and m for a bolted angle cleat

6.2.6.7 Beam flange and web in compression

- (1) The resultant of the design compression resistance of a beam flange and the adjacent compression zone of the beam web, may be assumed to act at the level of the centre of compression, see 6.2.7. The design compression resistance of the combined beam flange and web is given by the following expression:

$$F_{c,fb,Rd} = M_{c,Rd}/(h - t_{fb}) \quad \dots (6.21)$$

where:

h is the depth of the connected beam;

$M_{c,Rd}$ is the design moment resistance of the beam cross-section, reduced if necessary to allow for shear, see EN 1993-1-1. For a haunched beam $M_{c,Rd}$ may be calculated neglecting the intermediate flange.

t_{fb} is the flange thickness of the connected beam.

If the height of the beam including the haunch exceeds 600 mm the contribution of the beam web to the design compression resistance should be limited to 20%.

- (2) If a beam is reinforced with haunches they should be arranged such that:
 - the steel grade of the haunch should match that of the member;
 - the flange size and the web thickness of the haunch should not be less than that of the member;
 - the angle of the haunch flange to the flange of the member should not be greater than 45°;
 - the length of stiff bearing s_s should be taken as equal to the thickness of the haunch flange parallel to the beam.
- (3) If a beam is reinforced with haunches, the design resistance of beam web in compression should be determined according to 6.2.6.2.

6.2.6.8 Beam web in tension

- (1) In a bolted end-plate connection, the design tension resistance of the beam web should be obtained from:

$$F_{t,wb,Rd} = b_{eff,t,wb} t_{wb} f_{y,wb} / \gamma_{M0} \quad \dots (6.22)$$

- (2) The effective width $b_{eff,t,wb}$ of the beam web in tension should be taken as equal to the effective length of the equivalent T-stub representing the end-plate in bending, obtained from 6.2.6.5 for an individual bolt-row or a bolt-group.

6.2.6.9 Concrete in compression including grout

- (1) The design bearing strength of the joint between the base plate and its concrete support should be determined taking account of the material properties and dimensions of both the grout and the concrete support. The concrete support should be designed according to EN 1992.
- (2) The design resistance of concrete in compression, including grout, together with the associated base plate in bending $F_{c,pl,Rd}$, should be taken as similar to those of an equivalent T-stub, see 6.2.5.

6.2.6.10 Base plate in bending under compression

- (1) The design resistance of a base plate in bending under compression, together with concrete slab on which the column base is placed $F_{c,pl,Rd}$, should be taken as similar to those of an equivalent T-stub, see 6.2.5.

6.2.6.11 Base plate in bending under tension

- (1) The design resistance and failure mode of a base plate in bending under tension, together with the associated anchor bolts in tension $F_{t,pl,Rd}$, may be determined using the rules given in 6.2.6.5.
- (2) In the case of base plates prying forces which may develop should $\overline{AC2}$ not be taken into consideration when determining the thickness of the base plate. Prying forces should be taken into account when determining the anchor bolts. $\overline{AC2}$

6.2.6.12 Anchor bolt in tension

- (1) Anchor bolts should be designed to resist the effects of the design loads. They should provide design resistance to tension due to uplift forces and bending moments where appropriate.
- (2) When calculating the tension forces in the anchor bolts due to bending moments, the lever arm should not be taken as more than the distance between the centroid of the bearing area on the compression side and the centroid of the bolt group on the tension side.

NOTE: Tolerances on the positions of the anchor bolts may have an influence.

- (3) The design resistance of the anchor bolts should be taken as the smaller of the design tension resistance of the anchor bolt, see 3.6, and the design bond resistance of the concrete on the anchor bolt according to EN 1992-1-1.
- (4) One of the following methods should be used to secure anchor bolts into the foundation:
- a hook (Figure 6.14(a)),
 - a washer plate (Figure 6.14(b)),
 - some other appropriate load distributing member embedded in the concrete,
 - some other fixing which has been adequately tested and approved.
- (5) When the bolts are provided with a hook, the anchorage length should be such as to prevent bond failure before yielding of the bolt. The anchorage length should be calculated in accordance with EN 1992-1-1. This type of anchorage should not be used for bolts with a yield strength f_{yb} higher than 300 N/mm^2 .
- (6) When the anchor bolts are provided with a washer plate or other load distributing member, no account should be taken of the contribution of bond. The whole of the force should be transferred through the load distributing device.

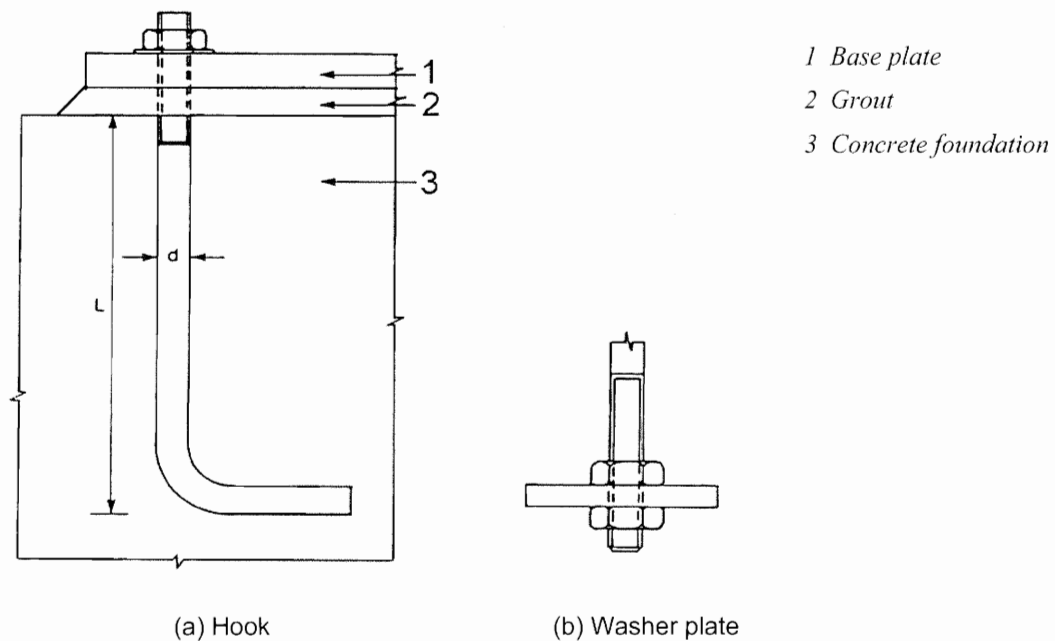


Figure 6.14: Fixing of anchor bolts

6.2.7 Design moment resistance of beam-to-column joints and splices

6.2.7.1 General

- (1) The applied design moment $M_{j,Ed}$ should satisfy:

$$\frac{M_{j,Ed}}{M_{j,Rd}} \leq 1,0 \quad \dots (6.23)$$

- (2) The methods given in 6.2.7 for determining the design moment resistance of a joint $M_{j,Rd}$ do not take account of any co-existing axial force N_{Ed} in the connected member. They should not be used if the axial force in the connected member exceeds 5% of the design plastic resistance $N_{pl,Rd}$ of its cross-section.
- (3) If the axial force N_{Ed} in the connected beam exceeds 5% of the design resistance, $N_{pl,Rd}$, the following conservative method may be used:

$$\frac{M_{j,Ed}}{M_{j,Rd}} + \frac{N_{j,Ed}}{N_{j,Rd}} \leq 1,0 \quad \dots (6.24)$$

where:

$M_{j,Rd}$ is the design moment resistance of the joint, assuming no axial force;

$N_{j,Rd}$ is the axial design resistance of the joint, assuming no applied moment.

- (4) The design moment resistance of a welded joint should be determined as indicated in Figure 6.15(a).
- (5) The design moment resistance of a bolted joint with a flush end-plate that has only one bolt-row in tension (or in which only one bolt-row in tension is considered, see 6.2.3(6)) should be determined as indicated in Figure 6.15(c).
- (6) The design moment resistance of a bolted joint with angle flange cleats should be determined as indicated in Figure 6.15(b).
- (7) The design moment resistance of a bolted end-plate joint with more than one row of bolts in tension should generally be determined as specified in 6.2.7.2.
- (8) As a conservative simplification, the design moment resistance of an extended end-plate joint with only two rows of bolts in tension may be approximated as indicated in Figure 6.16, provided that the total design resistance F_{Rd} does not exceed $3,8F_{t,Rd}$, where $F_{t,Rd}$ is given in Table 6.2. In this case the whole tension region of the end-plate may be treated as a single basic component. Provided that the two bolt-rows are approximately equidistant either side of the beam flange, this part of the end-plate may be treated as a T-stub to determine the bolt-row force $F_{1,Rd}$. The value of $F_{2,Rd}$ may then be assumed to be equal to $F_{1,Rd}$, and so F_{Rd} may be taken as equal to $2F_{1,Rd}$.
- (9) The centre of compression should be taken as the centre of the stress block of the compression forces. As a simplification the centre of compression may be taken as given in Figure 6.15.
- (10) A splice in a member or part subject to tension should be designed to transmit all the moments and forces to which the member or part is subjected at that point.
- (11) Splices should be designed to hold the connected members in place. Friction forces between contact surfaces may not be relied upon to hold connected members in place in a bearing splice.
- (12) Wherever practicable the members should be arranged so that the centroidal axis of any splice material coincides with the centroidal axis of the member. If eccentricity is present then the resulting forces should be taken into account.

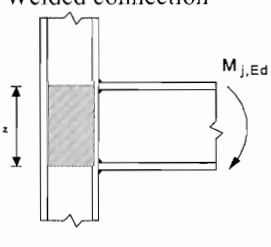
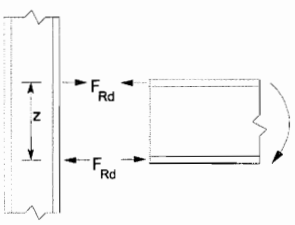
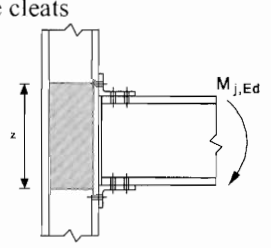
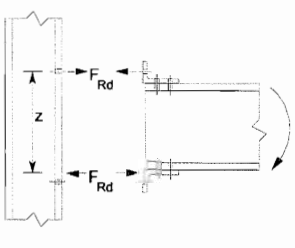
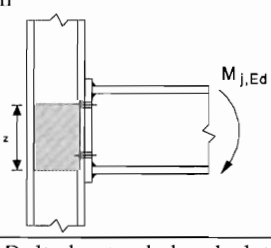
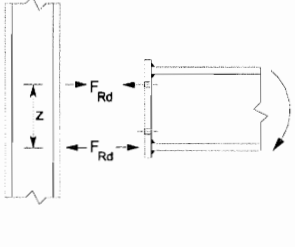
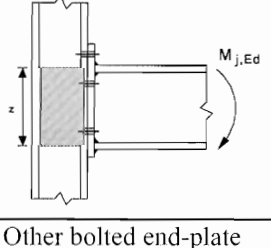
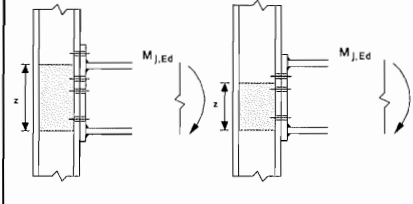
Type of connection	Centre of compression	Lever arm	Force distributions
<p>a) Welded connection</p> 	In line with the mid thickness of the compression flange	$z = h - t_{fb}$ h is the depth of the connected beam t_{fb} is the thickness of the beam flange	
<p>b) Bolted connection with angle flange cleats</p> 	In line with the mid-thickness of the leg of the angle cleat on the compression flange	Distance from the centre of compression to the bolt-row in tension	
<p>c) Bolted end-plate connection with only one bolt-row active in tension</p> 	In line with the mid-thickness of the compression flange	Distance from the centre of compression to the bolt-row in tension	
<p>d) Bolted extended end-plate connection with only two bolt-rows active in tension</p> 	In line with the mid-thickness of the compression flange	Conservatively z may be taken as the distance from the centre of compression to a point midway between these two bolt-rows	
<p>e) Other bolted end-plate connections with two or more bolt-rows in tension</p> 	In line with the mid-thickness of the compression flange	An approximate value may be obtained by taking the distance from the centre of compression to a point midway between the farthest two bolt-rows in tension	A more accurate value may be determined by taking the lever arm z as equal to z_{eq} obtained using the method given in 6.3.3.1.

Figure 6.15: Centre of compression, lever arm z and force distributions for deriving the design moment resistance $M_{j,Rd}$

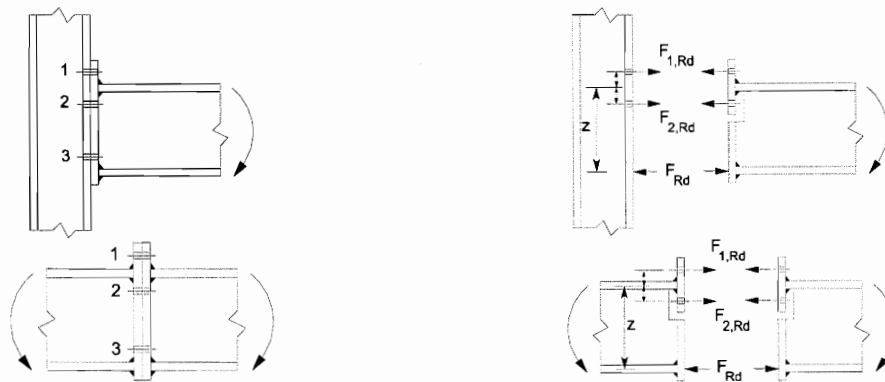


Figure 6.16: Simplified models for bolted joints with extended end-plates

- (13) Where the members are not prepared for full contact in bearing, splice material should be provided to transmit the internal forces and moments in the member at the spliced section, including the moments due to applied eccentricity, initial imperfections and second-order deformations. The internal forces and moments should be taken as not less than a moment equal to 25% of the moment capacity of the weaker section about both axes and a shear force equal to 2.5% of the normal force capacity of the weaker section in the directions of both axes.
- (14) Where the members are prepared for full contact in bearing, splice material should be provided to $\boxed{AC2}$ transmit at least 25% $\boxed{AC2}$ of the maximum compressive force in the column.
- (15) The alignment of the abutting ends of members subjected to compression should be maintained by cover plates or other means. The splice material and its fastenings should be proportioned to carry forces at the abutting ends, acting in any direction perpendicular to the axis of the member. In the design of splices the second order effects should also be taken into account.
- (16) Splices in flexural members should comply with the following:
- Compression flanges should be treated as compression members;
 - Tension flanges should be treated as tension members;
 - Parts subjected to shear should be designed to transmit the following effects acting together:
 - the shear force at the splice;
 - the moment resulting from the eccentricity, if any, of the centroids of the groups of fasteners on each side of the splice;
 - the proportion of moment, deformation or rotations carried by the web or part, irrespective of any shedding of stresses into adjoining parts assumed in the design of the member or part.

6.2.7.2 Beam-to-column joints with bolted end-plate connections

- (1) The design moment resistance $M_{j,Rd}$ of a beam-to-column joint with a bolted end-plate connection may be determined from:

$$M_{j,Rd} = \sum_r h_r F_{t,r,Rd} \quad \dots (6.25)$$

where:

- $F_{t,r,Rd}$ is the effective design tension resistance of bolt-row r ;
 h_r is the distance from bolt-row r to the centre of compression;
 r is the bolt-row number.

NOTE: In a bolted joint with more than one bolt-row in tension, the bolt-rows are numbered starting from the bolt-row farthest from the centre of compression.

- (2) For bolted end-plate connections, the centre of compression should be assumed to be in line with the centre of the compression flange of the connected member.
- (3) The effective design tension resistance $F_{tr,Rd}$ for each bolt-row should be determined in sequence, starting from bolt-row 1, the bolt-row farthest from the centre of compression, then progressing to bolt-row 2, etc.
- (4) When determining the effective design tension resistance $F_{tr,Rd}$ for bolt-row r the effective design tension resistance of all other bolt-rows closer to the centre of compression should be ignored.
- (5) The effective design tension resistance $F_{tr,Rd}$ of bolt-row r should be taken as its design tension resistance $F_{t,Rd}$ as an individual bolt-row determined from 6.2.7.2(6), reduced if necessary to satisfy the conditions specified in 6.2.7.2(7), (8) and (9).

- (6) The effective design tension resistance $F_{tr,Rd}$ of bolt-row r , taken as an individual bolt-row, should be taken as the smallest value of the design tension resistance for an individual bolt-row of the following basic components:

- the column web in tension	$F_{t,wc,Rd}$	-	see 6.2.6.3;
- the column flange in bending	$F_{t,fc,Rd}$	-	see 6.2.6.4;
- the end-plate in bending	$F_{t,ep,Rd}$	-	see 6.2.6.5;
- the beam web in tension	$F_{t,wb,Rd}$	-	see 6.2.6.8.

- (7) The effective design tension resistance $F_{tr,Rd}$ of bolt-row r should, if necessary, be reduced below the value of $F_{t,Rd}$ AC2 *text deleted* AC2 to ensure that, when account is taken of all bolt-rows up to and including bolt-row r the following conditions are satisfied:

- the total design resistance $\sum F_{t,Rd} \leq V_{wp,Rd}/\beta$ - with β from 5.3(7) - see 6.2.6.1;
- the total design resistance $\sum F_{t,Rd}$ does not exceed the smaller of:
 - the design resistance of the column web in compression $F_{c,wc,Rd}$ - see 6.2.6.2;
 - the design resistance of the beam flange and web in compression $F_{c,fb,Rd}$ - see 6.2.6.7.

- (8) The effective design tension resistance $F_{tr,Rd}$ of bolt-row r should, if necessary, be reduced below the value of $F_{t,Rd}$ AC2 *text deleted* AC2, to ensure that the sum of the design resistances taken for the bolt-rows up to and including bolt-row r that form part of the same group of bolt-rows, does not exceed the design resistance of that group as a whole. This should be checked for the following basic components:

- the column web in tension	$F_{t,wc,Rd}$	-	see 6.2.6.3;
- the column flange in bending	$F_{t,fc,Rd}$	-	see 6.2.6.4;
- the end-plate in bending	$F_{t,ep,Rd}$	-	see 6.2.6.5;
- the beam web in tension	$F_{t,wb,Rd}$	-	see 6.2.6.8.

- (9) Where the effective design tension resistance $F_{tr,Rd}$ of one of the previous bolt-rows x is greater than $1,9F_{t,Rd}$, then the effective design tension resistance $F_{tr,Rd}$ for bolt-row r should be reduced, if necessary, in order to ensure that:

$$F_{tr,Rd} \leq F_{tx,Rd} h_r / h_x \quad \dots (6.26)$$

where:

h_x is the distance from bolt-row x to the centre of compression;

x is the bolt-row farthest from the centre of compression that has a design tension resistance greater than $1,9F_{t,Rd}$.

NOTE: The National Annex may give further information on the use of equation (6.26).

- (10) The method described in 6.2.7.2(1) to 6.2.7.2(9) may be applied to a bolted beam splice with welded end-plates, see Figure 6.17, by omitting the items relating to the column.

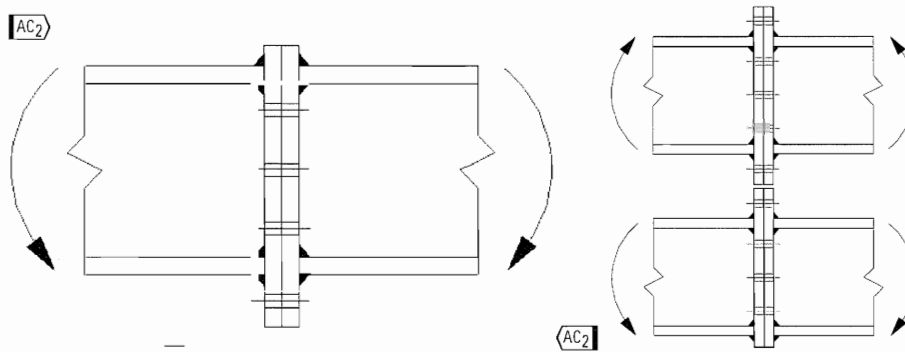


Figure 6.17: Bolted beam splices with welded end-plates

6.2.8 Design resistance of column bases with base plates

6.2.8.1 General

- (1) Column bases should be of sufficient size, stiffness and strength to transmit the axial forces, bending moments and shear forces in columns to their foundations or other supports without exceeding the load carrying capacity of these supports.
- (2) The design bearing strength between the base plate and its support may be determined on the basis of a uniform distribution of compressive force over the bearing area. For concrete foundations the bearing stress should not exceed the design bearing strength, f_{jd} , given in 6.2.5(7).
- (3) For a column base subject to combined axial force and bending the forces between the base plate and its support can take one of the following distribution depending on the relative magnitude of the applied axial force and bending moment:
 - In the case of a dominant compressive axial force, full compression may develop under both column flanges as shown in Figure 6.18(a).
 - In the case of a dominant tensile force, full tension may develop under both flanges as shown in Figure 6.18(b).
 - In the case of a dominant bending moment compression may develop under one column flange and tension under the other as shown in Figure 6.18(c) and Figure 6.18(d).
- (4) Base plates should be designed using the appropriate methods given in 6.2.8.2 and 6.2.8.3.
- (5) One of the following methods should be used to resist the shear force between the base plate and its support:
 - AC2 - Frictional design resistance at the joint between the base plate and its support added up with the design shear resistance of the anchor bolts. AC2
 - The design shear resistance of the surrounding part of the foundation.

If anchor bolts are used to resist the shear forces between the base plate and its support, rupture of the concrete in bearing should also be checked, according to EN 1992.

Where the above methods are inadequate special elements such as blocks or bar shear connectors should be used to transfer the shear forces between the base plate and its support.

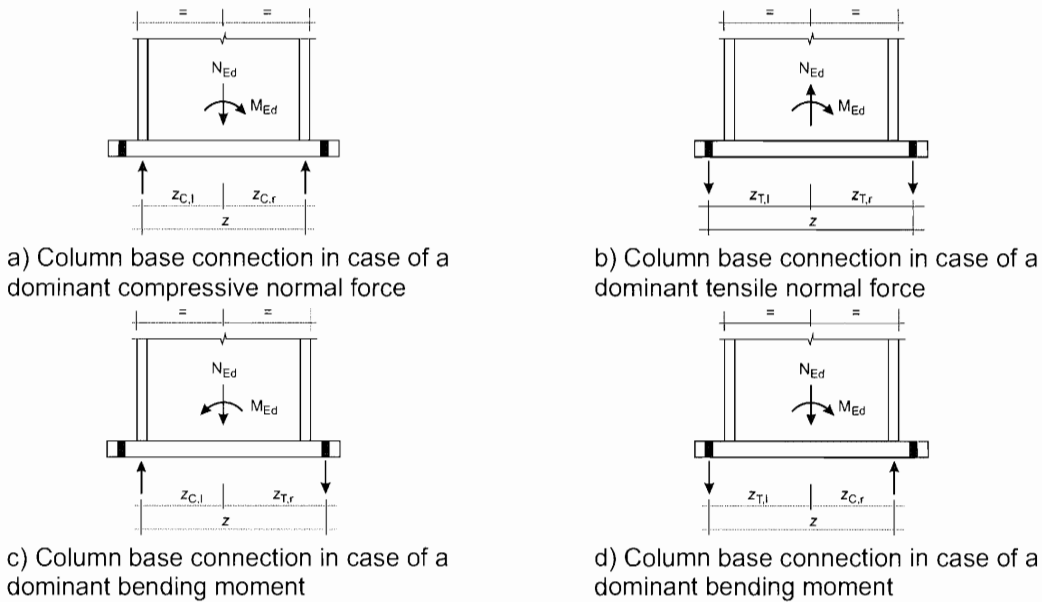


Figure 6.18: Determination of the lever arm z for column base connections

6.2.8.2 Column bases only subjected to axial forces

- (1) The design resistance, $N_{j,Rd}$, of a symmetric column base plate subject to an axial compressive force applied concentrically may be determined by adding together the individual design resistance $F_{C,Rd}$ of the three T-stubs shown in Figure 6.19 (Two T-stubs under the column flanges and one T-stub under the column web.) The three T-stubs should not be overlapping, see Figure 6.19. The design resistance of each of these T-stubs should be calculated using the method given in 6.2.5.

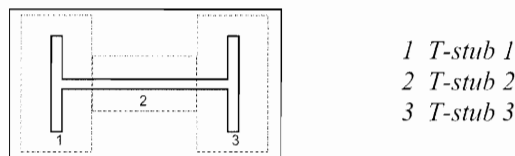


Figure 6.19: Non overlapping T-stubs

6.2.8.3 Column bases subjected to axial forces and bending moments

- (1) The design moment resistance $M_{j,Rd}$ of a column base subject to combined axial force and moment should be determined using the method given in Table 6.7 where the contribution of the concrete portion just under the column web (T-stub 2 of Figure 6.19) to the compressive capacity is omitted. The following parameters are used in this method:

- $F_{T,l,Rd}$ is the design tension resistance of the left hand side of the joint - see 6.2.8.3(2)
- $F_{T,r,Rd}$ is the design tension resistance of the right hand side of the joint - see 6.2.8.3(3)
- $F_{C,l,Rd}$ is the design compressive resistance of the left hand side of the joint - see 6.2.8.3(4)
- $F_{C,r,Rd}$ is the design compressive resistance of the right hand side of the joint - see 6.2.8.3(5)

- (2) The design tension resistance $F_{T,l,Rd}$ of the left side of the joint should be taken as the smallest values of the design resistance of following basic components:
- the column web in tension under the left column flange $F_{t,wc,Rd}$ - see 6.2.6.3;
 - the base plate in bending under the left column flange $F_{t,pl,Rd}$ - see 6.2.6.11.
- (3) The design tension resistance $F_{T,r,Rd}$ of the right side of the joint should be taken as the smallest values of the design resistance of following basic components:
- the column web in tension under the right column flange $F_{t,wc,Rd}$ - see 6.2.6.3;
 - the base plate in bending under the right column flange $F_{t,pl,Rd}$ - see 6.2.6.11.
- (4) The design compressive resistance $F_{C,l,Rd}$ of the left side of the joint should be taken as the smallest values of the design resistance of following basic components:
- the concrete in compression under the left column flange $F_{c,pl,Rd}$ - see 6.2.6.9;
 - the left column flange and web in compression $F_{c,fc,Rd}$ - see 6.2.6.7.
- (5) The design compressive resistance $F_{C,r,Rd}$ of the right side of the joint should be taken as the smallest values of the design resistance of following basic components:
- the concrete in compression under the right column flange $F_{c,pl,Rd}$ - see 6.2.6.9;
 - the right column flange and web in compression $F_{c,fc,Rd}$ - see 6.2.6.7.
- (6) For the calculation of $z_{T,l}$, $z_{C,l}$, $z_{T,r}$, $z_{C,r}$ see 6.2.8.1.

Table 6.7: Design moment resistance $M_{j,Rd}$ of column bases

Loading	Lever arm z	Design moment resistance $M_{j,Rd}$	
Left side in tension Right side in compression	$z = z_{T,l} + z_{C,r}$	$N_{Ed} > 0$ and $e > z_{T,l}$	$N_{Ed} \leq 0$ and $e \leq -z_{C,r}$
		The smaller of $\frac{F_{T,l,Rd} z}{z_{C,r} / e + 1}$ and $\frac{-F_{C,r,Rd} z}{z_{T,l} / e - 1}$	
Left side in tension Right side in tension	$z = z_{T,l} + z_{T,r}$	$N_{Ed} > 0$ and $0 < e < z_{T,l}$	$N_{Ed} > 0$ and $-z_{T,r} < e \leq 0$
		The smaller of $\frac{F_{T,l,Rd} z}{z_{T,r} / e + 1}$ and $\frac{F_{T,r,Rd} z}{z_{T,l} / e - 1}$ and $\frac{F_{T,l,Rd} z}{z_{T,r} / e + 1}$ and $\frac{F_{T,r,Rd} z}{z_{T,l} / e - 1}$	
Left side in compression Right side in tension	$z = z_{C,l} + z_{T,r}$	$N_{Ed} > 0$ and $e \leq -z_{T,r}$	$N_{Ed} \leq 0$ and $e > z_{C,l}$
		The smaller of $\frac{-F_{C,l,Rd} z}{z_{T,r} / e + 1}$ and $\frac{F_{T,r,Rd} z}{z_{C,l} / e - 1}$	
Left side in compression Right side in compression	$z = z_{C,l} + z_{C,r}$	$N_{Ed} \leq 0$ and $0 < e < z_{C,l}$	$N_{Ed} \leq 0$ and $-z_{C,r} < e \leq 0$
		The smaller of $\frac{-F_{C,l,Rd} z}{z_{C,r} / e + 1}$ and $\frac{-F_{C,r,Rd} z}{z_{C,l} / e - 1}$ and $\frac{-F_{C,l,Rd} z}{z_{C,r} / e + 1}$ and $\frac{-F_{C,r,Rd} z}{z_{C,l} / e - 1}$	
$M_{Ed} > 0$ is clockwise, $N_{Ed} > 0$ is tension $e = \frac{M_{Ed}}{N_{Ed}} = \frac{M_{Rd}}{N_{Rd}}$			

6.3 Rotational stiffness

6.3.1 Basic model

- (1) The rotational stiffness of a joint should be determined from the flexibilities of its basic components, each represented by an elastic stiffness coefficient k_i obtained from 6.3.2.

NOTE: These elastic stiffness coefficients are for general application.

- (2) For a bolted end-plate joint with more than one row of bolts in tension, the stiffness coefficients k_i for the related basic components should be combined. For beam-to-column joints and beam splices a method is given in 6.3.3 and for column bases a method is given in 6.3.4.
- (3) In a bolted end plate joint with more than one bolt-row in tension, as a simplification the contribution of any bolt-row may be neglected, provided that the contributions of all other bolt-rows closer to the centre of compression are also neglected. The number of bolt-rows retained need not necessarily be the same as for the determination of the design moment resistance.
- (4) Provided that the axial force N_{Ed} in the connected member does not exceed 5% of the design resistance $N_{pl,Rd}$ of its cross-section, the rotational stiffness S_j of a beam-to-column joint or beam splice, for a moment $M_{j,Ed}$ less than the design moment resistance $M_{j,Rd}$ of the joint, may be obtained with sufficient accuracy from:

$$S_j = \frac{Ez^2}{\mu \sum_i \frac{1}{k_i}} \quad \dots (6.27)$$

where:

- k_i is the stiffness coefficient for basic joint component i ;
 z is the lever arm, see 6.2.7;
 μ is the stiffness ratio $S_{j,ini}/S_j$, see 6.3.1(6).

NOTE: The initial rotational stiffness $S_{j,ini}$ of the joint is given by expression (6.27) with $\mu = 1,0$.

- (5) The rotational stiffness S_j of a column base, for a moment $M_{j,Ed}$ less than the design moment resistance $M_{j,Rd}$ of the joint, may be obtained with sufficient accuracy from 6.3.4.
- (6) The stiffness ratio μ should be determined from the following:

$$\begin{aligned} & \text{if } M_{j,Ed} \leq 2/3 M_{j,Rd}: \\ & \mu = 1 \end{aligned} \quad \dots (6.28a)$$

$$\begin{aligned} & \text{if } 2/3 M_{j,Rd} < M_{j,Ed} \leq M_{j,Rd}: \\ & \mu = (1,5 M_{j,Ed} / M_{j,Rd})^\psi \end{aligned} \quad \dots (6.28b)$$

in which the coefficient ψ is obtained from Table 6.8.

Table 6.8: Value of the coefficient ψ

Type of connection	ψ
Welded	2,7
Bolted end-plate	2,7
Bolted angle flange cleats	3,1
Base plate connections	2,7

- (7) The basic components that should be taken into account when calculating the stiffness of a welded beam-to-column joint and a joint with bolted angle flange cleats are given in Table 6.9. Similarly, the basic components for a bolted end-plate connection and a base plate are given in Table 6.10. In both of these tables the stiffness coefficients, k_i , for the basic components are defined in Table 6.11.
- (8) For beam-to-column end plate joints the following procedure should be used for obtaining the joint stiffness. The equivalent stiffness coefficient, k_{eq} , and the equivalent lever arm, z_{eq} , of the joint should be obtained from 6.3.3. The stiffness of the joint should then be obtained from 6.3.1(4) based on the stiffness coefficients, k_{eq} (for the joint), k_i (for the column web in shear), and with the lever arm, z , taken equal to the equivalent lever arm of the joint, z_{eq} .

Table 6.9: Joints with welded connections or bolted angle flange cleat connections

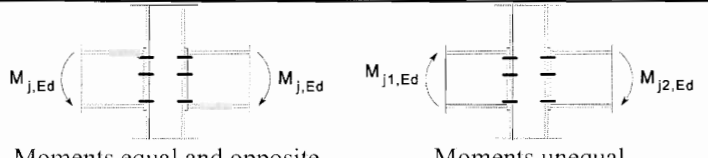
Beam-to-column joint with welded connections	Stiffness coefficients k_i to be taken into account
Single-sided	$k_1; k_2; k_3$
Double-sided – Moments equal and opposite	$k_2; k_3$
Double-sided – Moments unequal	$k_1; k_2; k_3$
Beam-to-column joint with Bolted angle flange cleat connections	Stiffness coefficients k_i to be taken into account
Single-sided	$k_1; k_2; k_3; k_4; k_6; k_{10}; k_{11}^*); k_{12}^{**})$
Double-sided – Moments equal and opposite	$k_2; k_3; k_4; k_6; k_{10}; k_{11}^*); k_{12}^{**})$
Double-sided – Moments unequal	$k_1; k_2; k_3; k_4; k_6; k_{10}; k_{11}^*); k_{12}^{**})$
 <p>Moments equal and opposite Moments unequal</p>	<p>*) Two k_{11} coefficients, one for each flange;</p> <p>**) Four k_{12} coefficients, one for each flange and one for each cleat.</p>

Table 6.10: Joints with bolted end-plate connections and base plate connections

Beam-to-column joint with bolted end-plate connections	Number of bolt-rows in tension	Stiffness coefficients k_i to be taken into account
Single-sided	One	$k_1; k_2; k_3; k_4; k_5; k_{10}$
	Two or more	$k_1; k_2; k_{eq}$
Double sided – Moments equal and opposite	One	$k_2; k_3; k_4; k_5; k_{10}$
	Two or more	$k_2; k_{eq}$
Double sided – Moments unequal	One	$k_1; k_2; k_3; k_4; k_5; k_{10}$
	Two or more	$k_1; k_2; k_{eq}$
Beam splice with bolted end-plates	Number of bolt-rows in tension	Stiffness coefficients k_i to be taken into account
Double sided - Moments equal and opposite	One	k_5 [left]; k_5 [right]; k_{10}
	Two or more	k_{eq}
Base plate connections	Number of bolt-rows in tension	Stiffness coefficients k_i to be taken into account
Base plate connections	One	$k_{13}; k_{15}; k_{16}$
	Two or more	$k_{13}; k_{15}$ and k_{16} for each bolt row

6.3.2 Stiffness coefficients for basic joint components

- (1) The stiffness coefficients for basic joint component should be determined using the expressions given in Table 6.11.

Table 6.11: Stiffness coefficients for basic joint components

Component	Stiffness coefficient k_i	
<i>Column web panel in shear</i>	unstiffened, single-sided joint, or a double-sided joint in which the beam depths are similar	stiffened
	$k_1 = \frac{0,38 A_{vC}}{\beta z}$	$k_1 = \infty$
	z is the lever arm from Figure 6.15; β is the transformation parameter from 5.3(7).	
<i>Column web in compression</i>	unstiffened	stiffened
	$k_2 = \frac{0,7 b_{eff,c,wc} t_{wc}}{d_c}$	$k_2 = \infty$
	$b_{eff,c,wc}$ is the effective width from 6.2.6.2	
<i>Column web in tension</i>	stiffened or unstiffened bolted connection with a single bolt-row in tension or unstiffened welded connection	stiffened welded connection
	$k_3 = \frac{0,7 b_{eff,t,wc} t_{wc}}{d_c}$	$k_3 = \infty$
	$b_{eff,t,wc}$ is the effective width of the column web in tension from 6.2.6.3. For a joint with a single bolt-row in tension, $b_{eff,t,wc}$ should be taken as equal to the smallest of the effective lengths ℓ_{eff} (individually or as part of a group of bolt-rows) given for this bolt-row in Table 6.4 (for an unstiffened column flange) or Table 6.5 (for a stiffened column flange).	
<i>Column flange in bending (for a single bolt-row in tension)</i>	$k_4 = \frac{0,9 \ell_{eff} t_{fc}^3}{m^3}$	
	ℓ_{eff} is the smallest of the effective lengths (individually or as part of a bolt group) for this bolt-row given in Table 6.4 for an unstiffened column flange or Table 6.5 for a stiffened column flange;	
	m is as defined in Figure 6.8.	
<i>End-plate in bending (for a single bolt-row in tension)</i>	$k_5 = \frac{0,9 \ell_{eff} t_p^3}{m^3}$	
	ℓ_{eff} is the smallest of the effective lengths (individually or as part of a group of bolt-rows) given for this bolt-row in Table 6.6;	
	m is generally as defined in Figure 6.11, but for a bolt-row located in the extended part of an extended end-plate $m = m_x$, where m_x is as defined in Figure 6.10.	
<i>Flange cleat in bending</i>	$k_6 = \frac{0,9 \ell_{eff} t_a^3}{m^3}$	
	ℓ_{eff} is the effective length of the flange cleat from Figure 6.12;	
	m is as defined in Figure 6.13.	

Component	Stiffness coefficient k_i	
<i>Bolts in tension</i> (for a single bolt-row)	$k_{10} = 1,6A_s / L_b$ preloaded or non-preloaded L_b is the bolt elongation length, taken as equal to the grip length (total thickness of material and washers), plus half the sum of the height of the bolt head and the height of the nut.	
<i>Bolts in shear</i>	non-preloaded	preloaded *)
	k_{11} (or $k_{17}) = \frac{16n_b d^2 f_{ub}}{Ed_{M16}}$	$k_{11} = \infty$
	d_{M16} is the nominal diameter of an M16 bolt; n_b is the number of bolt-rows in shear.	
<i>Bolts in bearing</i> (for each component j on which the bolts bear)	non-preloaded	preloaded *)
	k_{12} (or $k_{18}) = \frac{24n_b k_b k_t d f_u}{E}$	$k_{12} = \infty$
	$k_b = k_{b1}$ but $k_b \leq k_{b2}$ $k_{b1} = 0,25 e_b / d + 0,5$ but $k_{b1} \leq 1,25$ $k_{b2} = 0,25 p_b / d + 0,375$ but $k_{b2} \leq 1,25$ $k_t = 1,5 t_j / d_{M16}$ but $k_t \leq 2,5$	e_b is the distance from the bolt-row to the free edge of the plate in the direction of load transfer; f_u is the ultimate tensile strength of the steel on which the bolt bears; p_b is the spacing of the bolt-rows in the direction of load transfer; t_j is the thickness of that component.
<i>Concrete in compression</i> (including grout)	$k_{13} = \frac{E_c \sqrt{b_{eff} l_{eff}}}{1,275 E}$ b_{eff} is the effective width of the T-stub flange, see 6.2.5(3); l_{eff} is the effective length of the T-stub flange, see 6.2.5(3).	
<i>Plate in bending under compression</i>	$k_{14} = \infty$ This coefficient is already taken into consideration in the calculation of the stiffness coefficient k_{13}	
<i>Base plate in bending under tension</i> (for a single bolt row in tension)	with prying forces **)	without prying forces **)
	$k_{15} = \frac{0,85 \ell_{eff} t_p^3}{m^3}$	$k_{15} = \frac{0,425 \ell_{eff} t_p^3}{m^3}$
	ℓ_{eff} is the effective length of the T-stub flange, see 6.2.5(3); t_p is the thickness of the base plate; m is the distance according to Figure 6.8.	
<i>Anchor bolts in tension</i>	with prying forces **)	without prying forces **)
	$k_{16} = 1,6A_s / L_b$	$k_{16} = 2,0A_s / L_b$
	L_b is the anchor bolt elongation length, taken as equal to the sum of 8 times the nominal bolt diameter, the grout layer, the plate thickness, the washer and half of the height of the nut.	
*) provided that the bolts have been designed not to slip into bearing at the load level concerned **) prying forces may develop, if $L_b \leq \frac{8,8m^3 A_s}{l_{eff} t^3}$		

NOTE 1: When calculating b_{eff} and l_{eff} the distance c should be taken as 1,25 times the base plate thickness.

NOTE 2: Backing plates should be assumed not to affect the rotational stiffness S_j of the joint.

NOTE 3: For *welds* (k_{19}) the stiffness coefficient should be taken as equal to infinity. This component need not be taken into account when calculating the rotational stiffness S_j .

NOTE 4: For *beam flange and web in compression* (k_7), *beam web in tension* (k_8), *plate in tension or compression* (k_9), *haunched beams* (k_{20}), the stiffness coefficients should be taken as equal to infinity. These components need not be taken into account when calculating the rotational stiffness S_j .

NOTE 5: Where a *supplementary web plate* is used, the stiffness coefficients for the relevant basic joint components k_1 to k_3 should be increased as follows:

- k_1 for the column web panel in shear should be based on the increased shear area A_{vc} from 6.2.6.1(6);
- k_2 for the column web in compression should be based on the effective thickness of the web from 6.2.6.2(6);
- k_3 for the column web in tension, should be based on the effective thickness of the web from 6.2.6.3(8).

6.3.3 End-plate joints with two or more bolt-rows in tension

6.3.3.1 General method

- (1) For end-plate joints with two or more bolt-rows in tension, the basic components related to all of these bolt-rows should be represented by a single equivalent stiffness coefficient k_{eq} determined from:

$$k_{\text{eq}} = \frac{\sum k_{\text{eff},r} h_r}{z_{\text{eq}}} \quad \dots (6.29)$$

where:

h_r is the distance between bolt-row r and the centre of compression;

$k_{\text{eff},r}$ is the effective stiffness coefficient for bolt-row r taking into account the stiffness coefficients k_i for the basic components listed in 6.3.3.1(4) or 6.3.3.1(5) as appropriate;

z_{eq} is the equivalent lever arm, see 6.3.3.1(3).

- (2) The effective stiffness coefficient $k_{\text{eff},r}$ for bolt-row r should be determined from:

$$k_{\text{eff},r} = \frac{1}{\sum_i \frac{1}{k_{i,r}}} \quad \dots (6.30)$$

where:

$k_{i,r}$ is the stiffness coefficient representing component i relative to bolt-row r .

- (3) The equivalent lever arm z_{eq} should be determined from:

$$z_{\text{eq}} = \frac{\sum_r k_{\text{eff},r} h_r^2}{\sum_r k_{\text{eff},r} h_r} \quad \dots (6.31)$$

- (4) In the case of a beam-to-column joint with an end-plate connection, k_{eq} should be based upon (and replace) the stiffness coefficients k_i for:
- the column web in tension (k_3);
 - the column flange in bending (k_4);
 - the end-plate in bending (k_5);
 - the bolts in tension (k_{10}).
- (5) In the case of a beam splice with bolted end-plates, k_{eq} should be based upon (and replace) the stiffness coefficients k_i for:
- the end-plates in bending (k_5);
 - the bolts in tension (k_{10}).

6.3.3.2 Simplified method for extended end-plates with two bolt-rows in tension

- (1) For extended end-plate connections with two bolt-rows in tension, (one in the extended part of the end-plate and one between the flanges of the beam, see Figure 6.20), a set of modified values may be used for the stiffness coefficients of the related basic components to allow for the combined contribution of both bolt-rows. Each of these modified values should be taken as twice the corresponding value for a single bolt-row in the extended part of the end-plate.

NOTE: This approximation leads to a slightly lower estimate of the rotational stiffness.

- (2) When using this simplified method, the lever arm z should be taken as equal to the distance from the centre of compression to a point midway between the two bolt-rows in tension, see Figure 6.20.

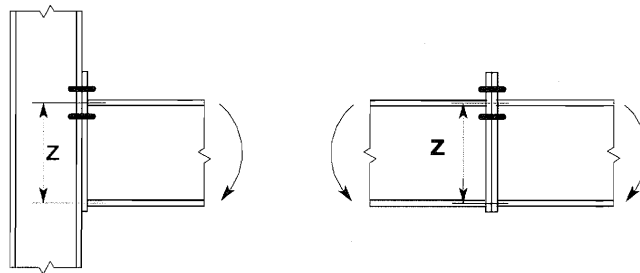


Figure 6.20: Lever arm z for simplified method

6.3.4 Column bases

- (1) The rotational stiffness, S_j , of a column base subject to combined axial force and bending moment should be calculated using the method given in Table 6.12. This method uses the following stiffness coefficients:

$k_{T,1}$ is the tension stiffness coefficient of the left hand side of the joint $\boxed{AC_2}$ and the inverse of it should be taken as equal to the sum of the inverses of the stiffness coefficients $\boxed{AC_2}$ k_{15} and k_{16} (given in Table 6.11) acting on the left hand side of the joint.

$k_{T,r}$ is the tension stiffness coefficient of the right hand side of the joint $\overline{\text{AC2}}$ and the inverse of it should be taken as equal to the sum of the inverses of the stiffness coefficients $\overline{\text{AC2}}$ k_{15} and k_{16} (given in Table 6.11) acting on the right hand side of the joint.

$k_{C,l}$ is the compression stiffness coefficient of the left hand side of the joint and should be taken as equal to the stiffness coefficient k_{13} (given in Table 6.11) acting on the left hand side of the joint.

$k_{C,r}$ is the compression stiffness coefficient of the right hand side of the joint and should be taken as equal to the stiffness coefficient k_{13} (given in Table 6.11) acting on the right hand side of the joint.

- (2) For the calculation of $z_{T,l}$, $z_{C,l}$, $z_{T,r}$, $z_{C,r}$ see 6.2.8.1.

Table 6.12: Rotational stiffness S_j of column bases

Loading	Lever arm z	Rotational stiffness $S_{j,ini}$	
Left side in tension Right side in compression	$z = z_{T,l} + z_{C,r}$	$N_{Ed} > 0$ and $e > z_{T,l}$	$N_{Ed} \leq 0$ and $e \leq -z_{C,r}$
		$\frac{Ez^2}{\mu(1/k_{T,l} + 1/k_{C,r})} \frac{e}{e + e_k}$ where $e_k = \frac{z_{C,r}k_{C,r} - z_{T,l}k_{T,l}}{k_{T,l} + k_{C,r}}$	
Left side in tension Right side in tension	$z = z_{T,l} + z_{T,r}$	$N_{Ed} > 0$ and $0 < e < z_{T,l}$	$N_{Ed} > 0$ and $-z_{T,r} < e \leq 0$
		$\frac{Ez^2}{\mu(1/k_{T,l} + 1/k_{T,r})} \frac{e}{e + e_k}$ where $e_k = \frac{z_{T,r}k_{T,r} - z_{T,l}k_{T,l}}{k_{T,l} + k_{T,r}}$	
Left side in compression Right side in tension	$z = z_{C,l} + z_{T,r}$	$N_{Ed} > 0$ and $e \leq -z_{T,r}$	$N_{Ed} \leq 0$ and $e > z_{C,l}$
		$\frac{Ez^2}{\mu(1/k_{C,l} + 1/k_{T,r})} \frac{e}{e + e_k}$ where $e_k = \frac{z_{T,r}k_{T,r} - z_{C,l}k_{C,l}}{k_{C,l} + k_{T,r}}$	
Left side in compression Right side in compression	$z = z_{C,l} + z_{C,r}$	$N_{Ed} \leq 0$ and $0 < e < z_{C,l}$	$N_{Ed} \leq 0$ and $-z_{C,r} < e \leq 0$
		$\frac{Ez^2}{\mu(1/k_{C,l} + 1/k_{C,r})} \frac{e}{e + e_k}$ where $e_k = \frac{z_{C,r}k_{C,r} - z_{C,l}k_{C,l}}{k_{C,l} + k_{C,r}}$	
$M_{Ed} > 0$ is clockwise, $N_{Ed} > 0$ is tension, μ see 6.3.1(6).			
$e = \frac{M_{Ed}}{N_{Ed}} = \frac{M_{Rd}}{N_{Rd}}$			

6.4 Rotation capacity

6.4.1 General

- $\overline{\text{AC1}}$ (1)P In the case of rigid plastic global analysis, a joint at a plastic hinge location shall have sufficient rotation capacity. $\overline{\text{AC1}}$
- (2) The rotation capacity of a bolted or welded joint should be determined using the provisions given in 6.4.2 or 6.4.3. The design methods given in these clauses are only valid for S235, S275 and S355 steel grades and for joints in which the design value of the axial force N_{Ed} in the connected member does not exceed 5% of the design plastic resistance $N_{pI,Rd}$ of its cross-section.
- (3) As an alternative to 6.4.2 and 6.4.3 the rotation capacity of a joint need not be checked provided that the design moment resistance $M_{j,Rd}$ of the joint is at least 1.2 times the design plastic moment resistance $M_{pI,Rd}$ of the cross section of the connected member.

- (4) In cases not covered by 6.4.2 and 6.4.3 the rotation capacity may be determined by testing in accordance with EN 1990, Annex D. Alternatively, appropriate calculation models may be used, provided that they are based on the results of tests in accordance with EN 1990.

6.4.2 Bolted joints

- (1) A beam-to-column joint in which the design moment resistance of the joint $M_{j,Rd}$ is governed by the design resistance of the column web panel in shear, may be assumed to have adequate rotation capacity for plastic global analysis, provided that $\sqrt{AC_2} d_{wc}/t_w \leq 69\epsilon \sqrt{AC_2}$.
- (2) A joint with either a bolted end-plate or angle flange cleat connection may be assumed to have sufficient rotation capacity for plastic analysis, provided that both of the following conditions are satisfied:
- the design moment resistance of the joint is governed by the design resistance of either:
 - the column flange in bending or
 - the beam end-plate or tension flange cleat in bending.
 - the thickness t of either the column flange or the beam end-plate or tension flange cleat (not necessarily the same basic component as in (a)) satisfies:

$$t \leq 0,36 d \sqrt{f_{ub} / f_y} \quad \dots (6.32)$$

where:

- f_y is the yield strength of the relevant basic component;
- $\sqrt{AC_2} d$ is the nominal diameter of the bolt;
- f_{ub} is the ultimate tensile strength of the bolt material. $\sqrt{AC_2}$

- (3) A joint with a bolted connection in which the design moment resistance $M_{j,Rd}$ is governed by the design resistance of its bolts in shear, should not be assumed to have sufficient rotation capacity for plastic global analysis.

6.4.3 Welded Joints

- (1) The rotation capacity ϕ_{Cd} of a welded beam-to-column connection may be assumed to be not less than the value given by the following expression provided that its column web is stiffened in compression but unstiffened in tension, and its design moment resistance is not governed by the design shear resistance of the column web panel, see 6.4.2(1):

$$\phi_{Cd} = 0,025 h_c / h_b \quad \dots (6.33)$$

where:

- h_b is the depth of the beam;
- h_c is the depth of the column.

- (2) An unstiffened welded beam-to-column joint designed in conformity with the provisions of this section, may be assumed to have a rotation capacity ϕ_{Cd} of at least 0,015 radians.

7 Hollow section joints

7.1 General

7.1.1 Scope

- (1) This section gives detailed application rules to determine the static design resistances of uniplanar and multiplanar joints in lattice structures composed of circular, square or rectangular hollow sections, and of uniplanar joints in lattice structures composed of combinations of hollow sections with open sections.
- (2) The static design resistances of the joints are expressed in terms of maximum design axial and/or moment resistances for the brace members.
- (3) These application rules are valid both for hot finished hollow sections to EN 10210 and for cold formed hollow sections to EN 10219, if the dimensions of the structural hollow sections fulfil the requirements of this section.
- (4) For hot finished hollow sections and cold formed hollow sections the nominal yield strength of the end product should not exceed 460 N/mm^2 . For end products with a nominal yield strength higher than 355 N/mm^2 , the static design resistances given in this section should be reduced by a factor 0,9.
- (5) The nominal wall thickness of hollow sections should not be less than 2,5 mm.
- (6) The nominal wall thickness of a hollow section chord should not be greater than 25 mm unless special measures have been taken to ensure that the through thickness properties of the material will be adequate.
- (7) For fatigue assessment see EN 1993-1-9.
- (8) The types of joints covered are indicated in Figure 7.1.

7.1.2 Field of application

- (1) The application rules for hollow section joints may be used only where all of the conditions given in 7.1.2(2) to 7.1.2(8) are satisfied.
- (2) The compression elements of the members should satisfy the requirements for Class 1 or Class 2 given in EN 1993-1-1 $\boxed{\text{AC}_2}$ for the condition of axial compression $\boxed{\text{AC}_2}$.
- (3) The angles θ_i between the chords and the brace members, and between adjacent brace members, should satisfy:
$$\theta_i \geq 30^\circ$$
- (4) The ends of members that meet at a joint should be prepared in such a way that their cross-sectional shape is not modified. Flattened end connections and cropped end connections are not covered in this section.
- (5) In gap type joints, in order to ensure that the clearance is adequate for forming satisfactory welds, the gap between the brace members should not be less than $(t_1 + t_2)$.
- (6) In overlap type joints, the overlap should be large enough to ensure that the interconnection of the brace members is sufficient for adequate shear transfer from one brace to the other. In any case the overlap should be at least 25%.

$\boxed{\text{AC}_2}$ If the overlap exceeds $\lambda_{\text{ov,lim.}}=60\%$ in case the hidden seam of the overlapped brace is not welded or $\lambda_{\text{ov,lim.}}=80\%$ in case the hidden seam of the overlapped brace is welded or if the braces are rectangular sections with $h_i < b_i$ and/or $h_j < b_j$, the connection between the braces and the chord face should be checked for shear. $\boxed{\text{AC}_2}$

- (7) Where overlapping brace members have different thicknesses and/or different strength grades, the member with the lowest $t_i f_{yi}$ value should overlap the other member.
- (8) Where overlapping brace members are of different widths, the narrower member should overlap the wider one.

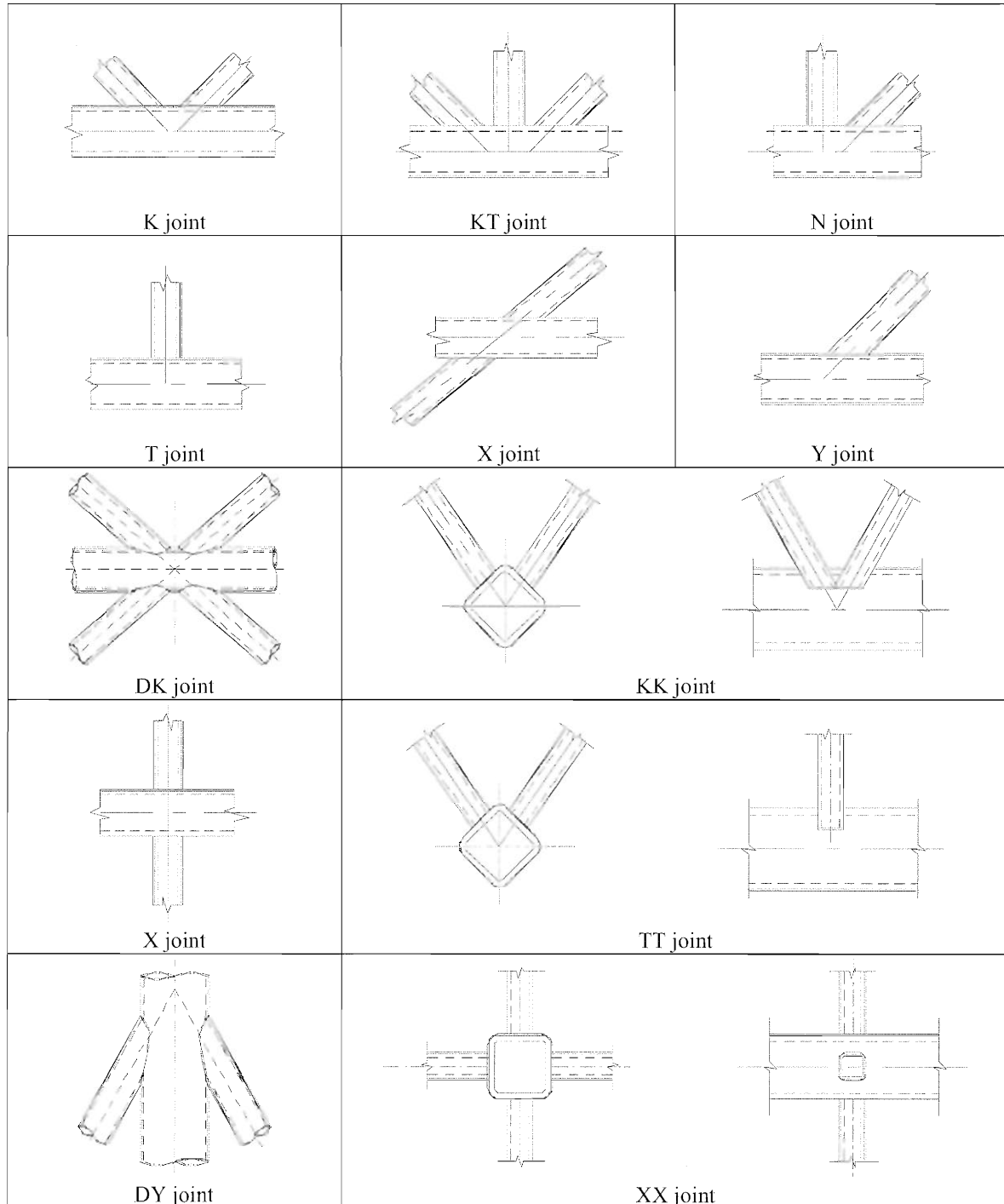


Figure 7.1: Types of joints in hollow section lattice girders

7.2 Design

7.2.1 General

- Ⓐ (1)P The design values of the internal axial forces both in the brace members and in the chords at the ultimate limit state shall not exceed the design resistances of the members determined from EN 1993-1-1.
- (2)P The design values of the internal axial forces in the brace members at the ultimate limit state shall also not exceed the design resistances of the joints given in 7.4, 7.5, 7.6 or 7.7 as appropriate. Ⓐ
- (3) The stresses $\sigma_{0,Ed}$ or $\sigma_{p,Ed}$ in the chord at a joint should be determined from:

$$\sigma_{0,Ed} = \frac{N_{0,Ed}}{A_0} + \frac{M_{0,Ed}}{W_{el,0}} \quad \dots (7.1)$$

$$\sigma_{p,Ed} = \frac{N_{p,Ed}}{A_0} + \frac{M_{0,Ed}}{W_{el,0}} \quad \dots (7.2)$$

where:

$$N_{p,Ed} = N_{0,Ed} - \sum_{i>0} N_{i,Ed} \cos \theta_i$$

7.2.2 Failure modes for hollow section joints

- (1) The design joint resistances of connections between hollow sections and of connections between hollow sections and open sections, should be based on the following failure modes as applicable:
- Chord face failure** (plastic failure of the chord face) or chord plastification (plastic failure of the chord cross-section);
 - Chord side wall failure** (or **chord web failure**) by yielding, crushing or instability (cripling or buckling of the chord side wall or chord web) under the compression brace member;
 - Chord shear failure**;
 - Punching shear** failure of a hollow section chord wall (crack initiation leading to rupture of the brace members from the chord member);
 - Brace failure** with reduced effective width (cracking in the welds or in the brace members);
 - Local buckling** failure of a brace member or of a hollow section chord member at the joint location.

NOTE: The phrases printed in boldface type in this list are used to describe the various failure modes in the tables of design resistances given in 7.4 to 7.7.

- (2) Figure 7.2 illustrates failure modes (a) to (f) for joints between CHS brace and chord members.
- (3) Figure 7.3 illustrates failure modes (a) to (f) for joints between RHS brace and chord members.
- (4) Figure 7.4 illustrates failure modes (a) to (f) for joints between CHS or RHS brace members and I or H section chord members.
- (5) Although the resistance of a joint with properly formed welds is generally higher under tension than under compression, the design resistance of the joint is generally based on the resistance of the brace in compression to avoid the possible excessive local deformation or reduced rotation capacity or deformation capacity which might otherwise occur.

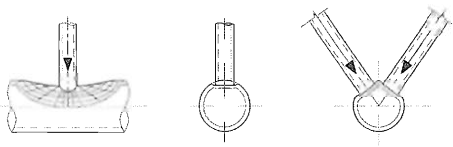
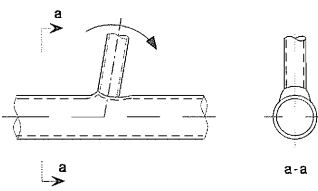
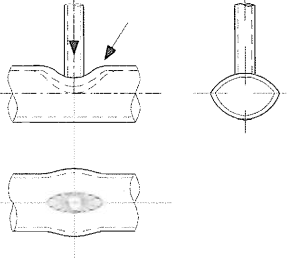
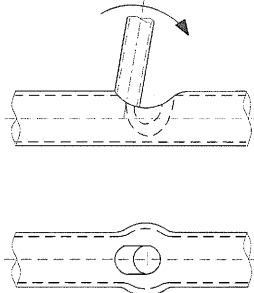
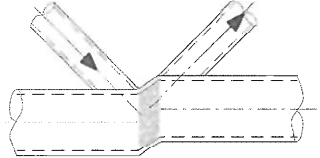
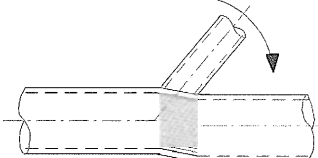
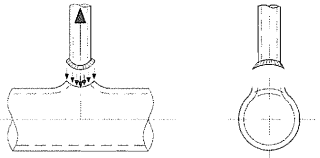
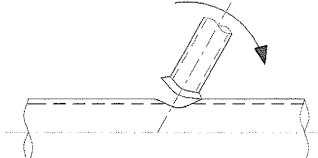
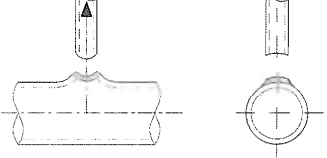
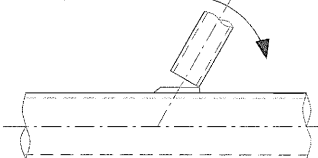
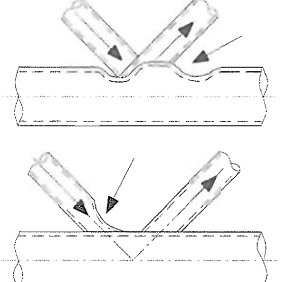
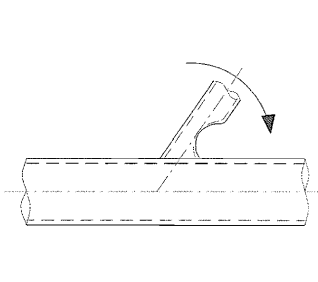
Mode	Axial loading	Bending moment
a		
b		
c		
d		
e		
f		

Figure 7.2: Failure modes for joints between CHS members

Mode	Axial loading	Bending moment
a		
b		
c		
d		
e		
f		

Figure 7.3: Failure modes for joints between RHS brace members and RHS chord members

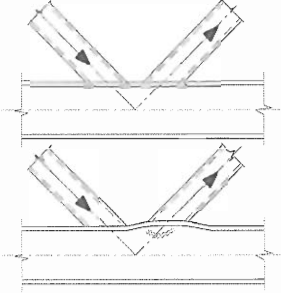
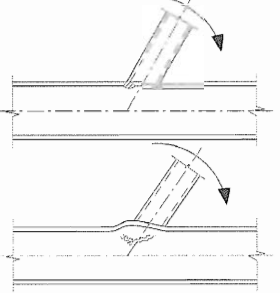
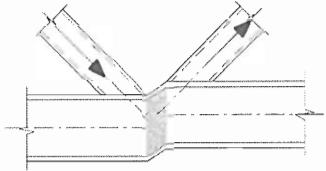
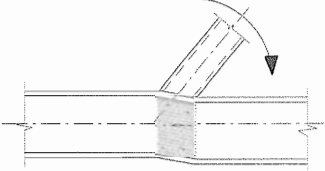
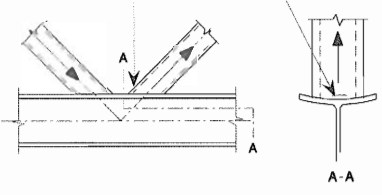
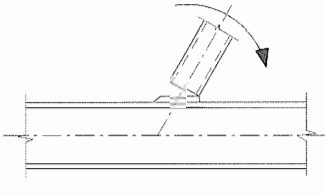
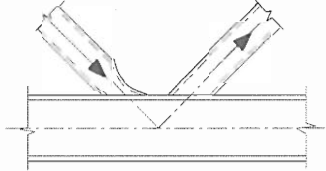
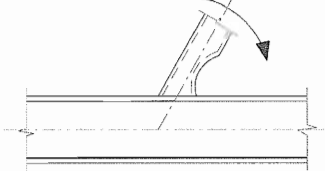
Mode	Axial loading	Bending moment
a	—	—
b		
c		
d	—	—
e		
f		

Figure 7.4: Failure modes for joints between CHS or RHS brace members and I or H section chord members

7.3 Welds

7.3.1 Design resistance

- Ⓐ (1)P The welds connecting the brace members to the chords shall be designed to have sufficient resistance to allow for non-uniform stress-distributions and sufficient deformation capacity to allow for redistribution of bending moments. Ⓐ
- (2) In welded joints, the connection should normally be formed around the entire perimeter of the hollow section by means of a butt weld, a fillet weld, or combinations of the two. However in partially overlapping joints the hidden part of the connection need not be welded, provided that the axial forces in the brace members are such that their components perpendicular to the axis of the chord do not differ by more than 20%.
 - (3) Typical weld details are indicated in 1.2.7 Reference Standards: Group 7.
 - (4) The design resistance of the weld, per unit length of perimeter of a brace member, should not normally be less than the design resistance of the cross-section of that member per unit length of perimeter.
 - (5) The required throat thickness should be determined from section 4.
 - (6) The criterion given in 7.3.1(4) may be waived where a smaller weld size can be justified both with regard to resistance and with regard to deformation capacity and rotation capacity, taking account of the possibility that only part of its length is effective.
 - (7) For rectangular structural hollow sections the design throat thickness of flare groove welds is defined in Figure 7.5.

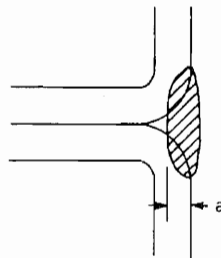


Figure 7.5: Design throat thickness of flare groove welds in rectangular structural hollow section

- (8) For welding in cold-formed zones, see 4.14.

7.4 Welded joints between CHS members

7.4.1 General

- (1) Provided that the geometry of the joints is within the range of validity given in Table 7.1, the design resistances of welded joints between circular hollow section members may be determined using 7.4.2 and 7.4.3.
- (2) For joints within the range of validity given in Table 7.1, only chord face failure and punching shear need be considered. The design resistance of a connection should be taken as the minimum value for these two criteria.
- (3) For joints outside the range of validity given in Table 7.1, $\boxed{\text{AC}_2}$ all the failure modes given in $\boxed{\text{AC}_2}$ 7.2.2 should be considered. In addition, the secondary moments in the joints caused by their rotational stiffness should be taken into account.

Table 7.1: Range of validity for welded joints between CHS brace members and CHS chords

$\boxed{\text{AC}_2}$	Diameter ratio	$0.2 \leq d_i/d_0 \leq 1,0$	
	Chords	tension	$10 \leq d_0/t_0 \leq 50$ (generally), but:
		compression	Class 1 or 2 and $10 \leq d_0/t_0 \leq 50$ (generally), but:
	Braces	tension	$d_i/t_i \leq 50$
		compression	Class 1 or 2
	Overlap	$25\% \leq \lambda_{ov} \leq \lambda_{ov,lim.}$, see 7.1.2 (6)	
	Gap	$g \geq t_1 + t_2$ $\boxed{\text{AC}_2}$	

7.4.2 Uniplanar joints

- $\boxed{\text{AC}_1}$ (1)P In brace member connections subject only to axial forces, the design internal axial force $N_{i,Ed}$ shall not exceed the design axial resistance of the welded joint $N_{i,Rd}$ obtained from Table 7.2, Table 7.3 or Table 7.4 as appropriate. $\boxed{\text{AC}_1}$
- (2) Brace member connections subject to combined bending and axial force should satisfy:

$$\boxed{\text{AC}_2} \frac{N_{i,Ed}}{N_{i,Rd}} + \left[\frac{M_{ip,i,Ed}}{M_{ip,i,Rd}} \right]^2 + \frac{|M_{op,i,Ed}|}{M_{op,i,Rd}} \leq 1,0 \quad \boxed{\text{AC}_2} \quad \dots (7.3)$$

where:

- $M_{ip,i,Rd}$ is the design in-plane moment resistance;
- $M_{ip,i,Ed}$ is the design in-plane internal moment;
- $M_{op,i,Rd}$ is the design out-of-plane moment resistance;
- $M_{op,i,Ed}$ is the design out-of-plane internal moment.

Table 7.2: Design axial resistances of welded joints between CHS brace members and CHS chords

Chord face failure - T and Y joints	
	$N_{1,Rd} = \frac{\gamma^{0,2} k_p f_{y0} t_0^2}{\sin \theta_1} (2,8 + 14,2 \beta^2) / \gamma_{M5}$
Chord face failure - X joints	
	$N_{1,Rd} = \frac{k_p f_{y0} t_0^2}{\sin \theta_1} \frac{5,2}{(1 - 0,81 \beta)} / \gamma_{M5}$
Chord face failure - K and N gap or overlap joints	
	$N_{1,Rd} = \frac{k_g k_p f_{y0} t_0^2}{\sin \theta_1} \left(1,8 + 10,2 \frac{d_1}{d_0} \right) / \gamma_{M5}$ $N_{2,Rd} = \frac{\sin \theta_1}{\sin \theta_2} N_{1,Rd}$
[AC2] Punching shear failure for K, N and KT gap joints and T, Y and X joints [i = 1, 2 or 3] [AC2]	
When $d_i \leq d_0 - 2t_0$: $N_{i,Rd} = \frac{f_{y0}}{\sqrt{3}} t_0 \pi d_i \frac{1 + \sin \theta_i}{2 \sin^2 \theta_i} / \gamma_{M5}$	
Factors k_g and k_p	
$k_g = \gamma^{0,2} \left(1 + \frac{0,024 \gamma^{1,2}}{1 + \exp(0,5g/t_0 - 1,33)} \right)$ (see Figure 7.6)	
For $n_p > 0$ (compression): $k_p = 1 - 0,3 n_p (1 + n_p)$ but $k_p \leq 1,0$ For $n_p \leq 0$ (tension): $k_p = 1,0$	

Table 7.3: Design resistances of welded joints connecting gusset plates to CHS members

Chord face failure	
	$N_{1,Rd} = k_p f_{y0} t_0^2 (4 + 20\beta^2) / \gamma_{M5}$ $M_{ip,1,Rd} = 0$ $M_{op,1,Rd} = 0,5 b_1 N_{1,Rd}$
	$N_{1,Rd} = \frac{5k_p f_{y0} t_0^2}{1 - 0,81\beta} / \gamma_{M5}$ $M_{ip,1,Rd} = 0$ $M_{op,1,Rd} = 0,5 b_1 N_{1,Rd}$
	$N_{1,Rd} = 5k_p f_{y0} t_0^2 (1 + 0,25\eta) / \gamma_{M5}$ $M_{ip,1,Rd} = h_1 N_{1,Rd}$ $M_{op,1,Rd} = 0$
	$N_{1,Rd} = 5k_p f_{y0} t_0^2 (1 + 0,25\eta) / \gamma_{M5}$ $M_{ip,1,Rd} = h_1 N_{1,Rd}$ $M_{op,1,Rd} = 0$
Punching shear failure	
$\sigma_{\max} t_1 = (N_{Ed} / A + M_{Ed} / W_{el}) t_1 \leq 2t_0 (f_{y0} / \sqrt{3}) / \gamma_{M5}$	
Range of validity	Factor k_p
In addition to the limits given in Table 7.1:	For $n_p > 0$ (compression):
$\beta \geq 0,4$ and $\eta \leq 4$	$k_p = 1 - 0,3 n_p (1 + n_p)$ but $k_p \leq 1,0$
where $\beta = b_1 / d_0$ and $\eta = h_1 / d_0$	For $n_p \leq 0$ (tension): $k_p = 1,0$

Table 7.4: Design resistances of welded joints connecting I, H or RHS sections to CHS members

Chord face failure	
	$N_{1,Rd} = k_p f_{y0} t_0^2 (4 + 20\beta^2)(1 + 0,25\eta) / \gamma_{M5}$ $M_{1p,1,Rd} = h_1 N_{1,Rd} / (1 + 0,25\eta)$ $M_{1op,1,Rd} = 0,5 b_1 N_{1,Rd}$
	$N_{1,Rd} = \frac{5k_p f_{y0} t_0^2}{1 - 0,81\beta} (1 + 0,25\eta) / \gamma_{M5}$ $M_{1p,1,Rd} = h_1 N_{1,Rd} / (1 + 0,25\eta)$ $M_{1op,1,Rd} = 0,5 b_1 N_{1,Rd}$
	$N_{1,Rd} = k_p f_{y0} t_0^2 (4 + 20\beta^2)(1 + 0,25\eta) / \gamma_{M5}$ $M_{1p,1,Rd} = h_1 N_{1,Rd}$ $M_{1op,1,Rd} = 0,5 b_1 N_{1,Rd}$
	$N_{1,Rd} = \frac{5k_p f_{y0} t_0^2}{1 - 0,81\beta} (1 + 0,25\eta) / \gamma_{M5}$ $M_{1p,1,Rd} = h_1 N_{1,Rd}$ $M_{1op,1,Rd} = 0,5 b_1 N_{1,Rd}$
Punching shear failure	
<p>AC2 I or H sections with $\eta > 2$ (for axial compression and out-of-plane bending) and RHS sections: $\sigma_{\max} t_1 = (N_{Ed,1} / A_1 + M_{Ed,1} / W_{el,1}) t_1 \leq t_0 (f_{y0} / \sqrt{3}) / \gamma_{M5}$</p> <p>All other cases: $\sigma_{\max} t_1 = (N_{Ed,1} / A_1 + M_{Ed,1} / W_{el,1}) t_1 \leq 2 t_0 (f_{y0} / \sqrt{3}) / \gamma_{M5}$</p> <p>where t_1 is the flange or wall thickness of the transverse I-, H-, or RHS section AC2</p>	
Range of validity	Factor k_p
<p>In addition to the limits given in Table 7.1:</p> <p>$\beta \geq 0,4$ and $\eta \leq 4$</p> <p>where $\beta = b_1 / d_0$ and $\eta = h_1 / d_0$</p>	<p>For $n_p > 0$ (compression):</p> <p>$k_p = 1 - 0,3 n_p (1 + n_p)$ but $k_p \leq 1,0$</p> <p>For $n_p \leq 0$ (tension): $k_p = 1,0$</p>

BS EN 1993-1-8:2005
EN 1993-1-8:2005 (E)

- (3) The design internal moment $M_{i,Ed}$ may be taken as the value at the point where the centreline of the brace member meets the face of the chord member.
- (4) The design in-plane moment resistance and the design out-of-plane moment resistance $M_{i,Rd}$ should be obtained from Table 7.3, Table 7.4 or Table 7.5 as appropriate.
- (5) The special types of welded joints indicated in Table 7.6 should satisfy the appropriate design criteria specified for each type in that table.
- (6) Values of the factor k_g which is used in Table 7.2 for K, N and KT joints are given in Figure 7.6. The factor k_g is used to cover both gap type and overlap type joints by adopting g for both the gap and the overlap and using negative values of g to represent the overlap q as defined in Figure 1.3(b).

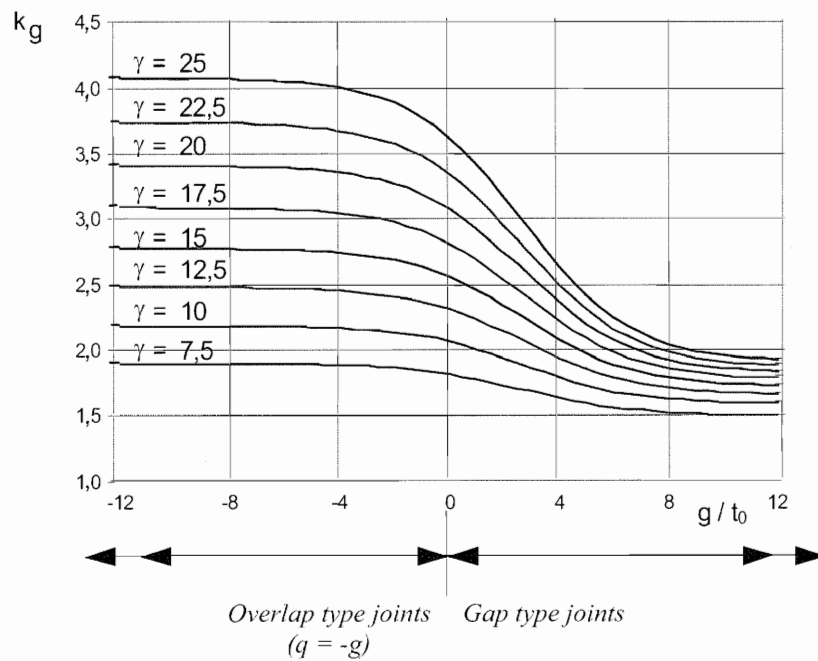
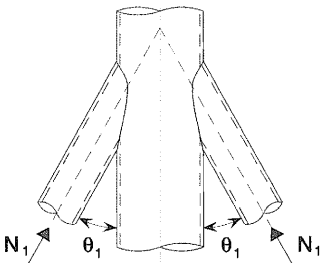
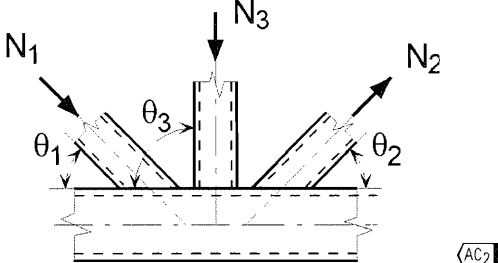
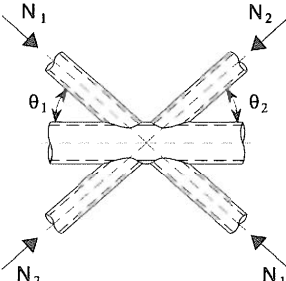
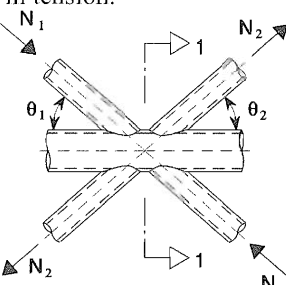


Figure 7.6: Values of the factor k_g for use in Table 7.2

Table 7.5: Design resistance moments of welded joints between CHS brace members and CHS chords

Chord face failure - T, X, and Y joints	
	$M_{ip,1,Rd} = 4,85 \frac{f_{y0} t_0^2 d_1}{\sin \theta_1} \sqrt{\gamma} \beta k_p / \gamma_{M5}$
Chord face failure - K, N, T, X and Y joints	
	$M_{op,1,Rd} = \frac{f_{y0} t_0^2 d_1}{\sin \theta_1} \frac{2,7}{1 - 0,81\beta} k_p / \gamma_{M5}$
Punching shear failure - K and N gap joints and all T, X and Y joints	
When $d_1 \leq d_0 - 2t_0$:	
$M_{ip,1,Rd} = \frac{f_{y0} t_0 d_1^2}{\sqrt{3}} \frac{1 + 3 \sin \theta_1}{4 \sin^2 \theta_1} / \gamma_{M5}$	
$M_{op,1,Rd} = \frac{f_{y0} t_0 d_1^2}{\sqrt{3}} \frac{3 + \sin \theta_1}{4 \sin^2 \theta_1} / \gamma_{M5}$	
Factor k_p	
For $n_p > 0$ (compression): $k_p = 1 - 0,3 n_p (1 + n_p)$ but $k_p \leq 1,0$ For $n_p \leq 0$ (tension): $k_p = 1,0$	

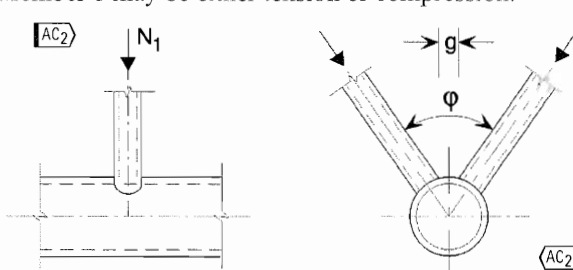
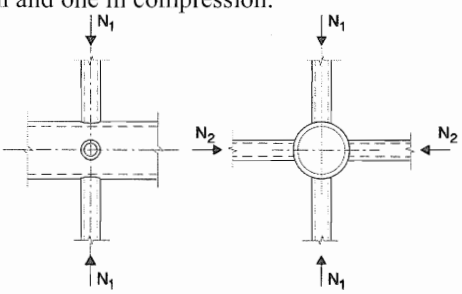
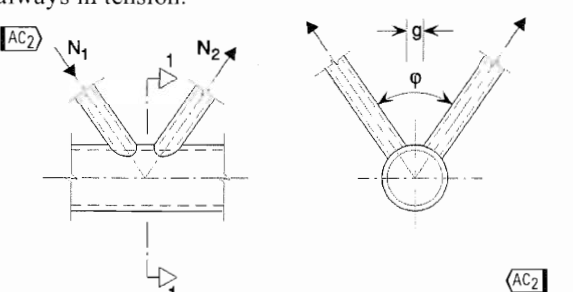
Table 7.6: Design criteria for special types of welded joints between CHS brace members and CHS chords

Type of joint	Design criteria
<p>The forces may be either tension or compression but should act in the same direction for both members.</p> 	$N_{1,Ed} \leq N_{1,Rd}$ <p>where $N_{1,Rd}$ is the value of $N_{1,Rd}$ for an X joint from Table 7.2.</p>
<p>AC2 Members 1 and 3 are here in compression and member 2 is here in tension.</p> 	$N_{1,Ed} \sin \theta_1 + N_{3,Ed} \sin \theta_3 \leq N_{1,Rd} \sin \theta_1$ $N_{2,Ed} \sin \theta_2 \leq N_{1,Rd} \sin \theta_1$ <p>where $N_{1,Rd}$ is the value of $N_{1,Rd}$ for a K joint from Table 7.2 but with $\frac{d_1}{d_0}$ replaced by: $\frac{d_1 + d_2 + d_3}{3d_0}$</p>
<p>All bracing members should always be in either compression or tension.</p> 	$N_{1,Ed} \sin \theta_1 + N_{2,Ed} \sin \theta_2 \leq N_{x,Rd} \sin \theta_x$ <p>where $N_{x,Rd}$ is the value of $N_{x,Rd}$ for an X joint from Table 7.2, where $N_{x,Rd} \sin \theta_x$ is the larger of:</p> $ N_{1,Rd} \sin \theta_1 \text{ and } N_{2,Rd} \sin \theta_2 $
<p>Member 1 is always in compression and member 2 is always in tension.</p> 	$N_{1,Ed} \leq N_{1,Rd}$ <p>where $N_{1,Rd}$ is the value of $N_{1,Rd}$ for a K joint from Table 7.2, provided that, in a gap-type joint, at section 1-1 the chord satisfies:</p> $\left[\frac{N_{0,Ed}}{N_{pl,0,Rd}} \right]^2 + \left[\frac{V_{0,Ed}}{V_{pl,0,Rd}} \right]^2 \leq 1,0$

7.4.3 Multiplanar joints

- (1) In each relevant plane of a multiplanar joint, the design criteria given in 7.4.2 should be satisfied using the reduced design resistances obtained from 7.4.3(2).
- (2) The design resistances for each relevant plane of a multiplanar joint should be determined by applying the appropriate reduction factor μ given in Table 7.7 to the resistance of the corresponding uniplanar joint calculated according to 7.4.2 by using the appropriate chord force for k_p .

Table 7.7: Reduction factors for multiplanar joints

Type of joint	Reduction factor μ
TT joint	$60^\circ \leq \varphi \leq 90^\circ$
<p>Member 1 may be either tension or compression.</p> 	$\mu = 1,0$
XX joint	
<p>Members 1 and 2 can be either in compression or tension. $N_{2,Ed}/N_{1,Ed}$ is negative if one member is in tension and one in compression.</p> 	$\mu = 1 + 0,33 N_{2,Ed} / N_{1,Ed}$ <p>taking account of the sign of $N_{1,Ed}$ and $N_{2,Ed}$ where $N_{2,Ed} \leq N_{1,Ed}$</p>
KK joint	$60^\circ \leq \varphi \leq 90^\circ$
<p>Member 1 is always in compression and member 2 is always in tension.</p> 	$\mu = 0,9$ <p>provided that, in a gap-type joint, at section 1-1 the chord satisfies:</p> $\left[\frac{N_{0,Ed}}{N_{pl,0,Rd}} \right]^2 + \left[\frac{V_{0,Ed}}{V_{pl,0,Rd}} \right]^2 \leq 1,0$

7.5 Welded joints between CHS or RHS brace members and RHS chord members

7.5.1 General

- (1) Provided that the geometry of the joints is within the range of validity given in Table 7.8, the design resistances of welded joints between hollow section brace members and rectangular or square hollow section chord members may be determined using 7.5.2 and 7.5.3.
- (2) For joints within the range of validity given in Table 7.8, only the design criteria covered in the appropriate table need be considered. The design resistance of a connection should be taken as the minimum value for all applicable criteria.
- (3) For joints outside the range of validity given in Table 7.8, $\overline{\text{AC2}}$ all the failure modes given in $\overline{\text{AC2}}$ 7.2.2 should be considered. In addition, the secondary moments in the joints caused by their rotational stiffness should be taken into account.

Table 7.8: Range of validity for welded joints between CHS or RHS brace members and RHS chord members

Type of joint	Joint parameters [$i = 1$ or 2 , $j =$ overlapped brace]					
	b_i/b_0 or d_i/b_0	b_i/t_i and h_i/t_i or d_i/t_i		h_0/b_0 and h_i/b_i	b_0/t_0 and h_0/t_0	Gap or overlap b_i/b_j
		Compression	Tension			
T, Y or X	$b_i/b_0 \geq 0,25$	$b_i/t_i \leq 35$ and $h_i/t_i \leq 35$	$b_i/t_i \leq 35$	$\geq 0,5$ but $\leq 2,0$	≤ 35 and $\overline{\text{AC2}}$ Class 1 or 2 $\overline{\text{AC2}}$	–
K gap N gap	$b_i/b_0 \geq 0,35$ and $\geq 0,1 + 0,01 b_0/t_0$	and $\overline{\text{AC2}}$ Class 1 or 2 $\overline{\text{AC2}}$	and $h_i/t_i \leq 35$		≤ 35 and $\overline{\text{AC2}}$ Class 1 or 2 $\overline{\text{AC2}}$	$g/b_0 \geq 0,5(1 - \beta)$ but $\leq 1,5(1 - \beta)$ ¹⁾ and as a minimum $g \geq t_1 + t_2$
K overlap N overlap	$b_i/b_0 \geq 0,25$	Class 1			$\overline{\text{AC2}}$ Class 1 or 2 $\overline{\text{AC2}}$	$\overline{\text{AC2}}$ $25\% \leq \lambda_{ov} \leq \lambda_{ov,lim.}$ ²⁾ $b_i/b_j \leq 0,75 \overline{\text{AC2}}$
Circular brace member	$d_i/b_0 \geq 0,4$ but $\leq 0,8$	Class 1	$d_i/t_i \leq 50$	As above but with d_i replacing b_i and d_j replacing b_j .		

¹⁾ If $g/b_0 > 1,5(1 - \beta)$ and $\overline{\text{AC2}}$ $g > t_1 + t_2 \overline{\text{AC2}}$ treat the joint as two separate T or Y joints.

²⁾ $\overline{\text{AC2}}$ $\lambda_{ov,lim.} = 60\%$ if the hidden seam is not welded and 80% if the hidden seam is welded. If the overlap exceeds $\lambda_{ov,lim.}$ or if the braces are rectangular sections with $h_i < b_i$ and/or $h_j < b_j$, the connection between the braces and chord face has to be checked for shear. $\overline{\text{AC2}}$

7.5.2 Uniplanar joints

7.5.2.1 Unreinforced joints

- (1) In brace member connections subject only to axial forces, the design internal axial force $N_{i,Ed}$ should not exceed the design axial resistance of the welded joint $N_{i,Rd}$, determined from 7.5.2.1(2) or 7.5.2.1(4) as appropriate.
- (2) For welded joints between square or circular hollow section brace members and square hollow section chord members only, where the geometry of the joints is within the range of validity given in Table 7.8 and also satisfies the additional conditions given in Table 7.9, the design axial resistances may be determined from the expressions given in Table 7.10.
- (3) For joints within the range of validity of Table 7.9, the only design criteria that need be considered are chord face failure and brace failure with reduced effective width. The design axial resistance should be taken as the minimum value for these two criteria.

NOTE: The design axial resistances for joints of hollow section brace members to square hollow section chords given in Table 7.10 have been simplified by omitting design criteria that are never critical within the range of validity of Table 7.9.

- (4) The design axial resistances of any unreinforced welded joint between CHS or RHS brace members and RHS chords, within the range of validity of Table 7.8, may be determined using the expressions given in ~~AC2~~ text deleted ~~AC2~~ Table 7.11, Table 7.12 or Table 7.13 as appropriate. For reinforced joints see 7.5.2.2.

Table 7.9: Additional conditions for the use of Table 7.10

Type of brace	Type of joint	Joint parameters	
Square hollow section	T, Y or X	$b_1/b_0 \leq 0,85$	$b_0/t_0 \geq 10$
	K gap or N gap	$0,6 \leq \frac{b_1 + b_2}{2b_1} \leq 1,3$	$b_0/t_0 \geq 15$
Circular hollow section	T, Y or X		$b_0/t_0 \geq 10$
	K gap or N gap	$0,6 \leq \frac{d_1 + d_2}{2d_1} \leq 1,3$	$b_0/t_0 \geq 15$

Table 7.10: Design axial resistances of welded joints between square or circular hollow section

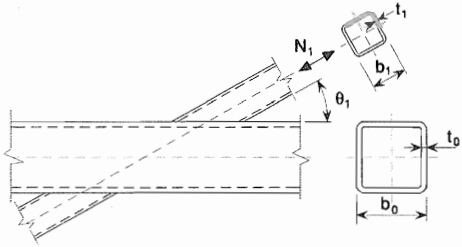
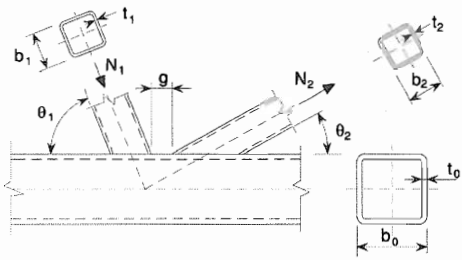
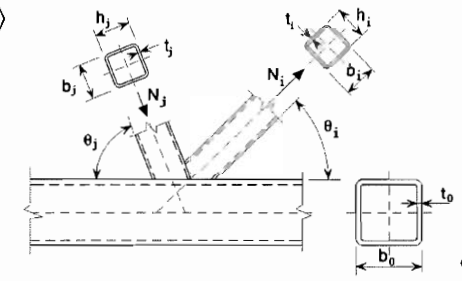
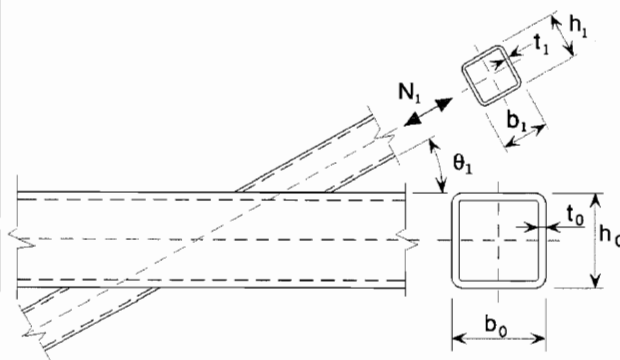
Type of joint	Design resistance [$i = 1$ or 2 , $j =$ overlapped brace]
T, Y and X joints	Chord face failure $\beta \leq 0,85$
	$N_{i,Rd} = \frac{k_n f_{y0} t_0^2}{(1 - \beta) \sin \theta_1} \left(\frac{2\beta}{\sin \theta_1} + 4\sqrt{1 - \beta} \right) / \gamma_{M5}$
K and N gap joints	Chord face failure $\beta \leq 1,0$
	$N_{i,Rd} = \frac{8,9 \gamma^{0,5} k_n f_{y0} t_0^2}{\sin \theta_i} \left(\frac{b_1 + b_2}{2b_0} \right) / \gamma_{M5}$
K and N overlap joints *)	Brace failure $25\% \leq \lambda_{ov} < 50\%$
Member i or member j may be either tension or compression but one should be tension and the other compression.	$\langle AC2 \rangle N_{i,Rd} = f_{yi} t_i \left(b_{eff} + b_{e,ov} + 2h_i \frac{\lambda_{ov}}{50} - 4t_i \right) / \gamma_{M5} \langle AC2 \rangle$
	Brace failure $50\% \leq \lambda_{ov} < 80\%$
	$N_{i,Rd} = f_{yi} t_i \left[b_{eff} + b_{e,ov} + 2h_i - 4t_i \right] / \gamma_{M5}$
	Brace failure $\lambda_{ov} \geq 80\%$
	$N_{i,Rd} = f_{yi} t_i \left[b_i + b_{e,ov} + 2h_i - 4t_i \right] / \gamma_{M5}$
Parameters b_{eff} , $b_{e,ov}$ and k_n	
$b_{eff} = \frac{10}{b_0 / t_0} \frac{f_{y0} t_0}{f_{yi} t_i} b_i \quad \text{but } b_{eff} \leq b_i$	For $n > 0$ (compression):
	$k_n = 1,3 - \frac{0,4n}{\beta}$
$b_{e,ov} = \frac{10}{b_j / t_j} \frac{f_{yj} t_j}{f_{yi} t_i} b_i \quad \text{but } b_{e,ov} \leq b_i$	but $k_n \leq 1,0$
	For $n \leq 0$ (tension):
	$k_n = 1,0$
For circular braces, multiply the above resistances by $\pi/4$, replace b_1 and h_1 by d_1 and replace b_2 and h_2 by d_2 .	
*) Only the overlapping brace member i need be checked. The brace member efficiency (i.e. the design resistance of the joint divided by the design plastic resistance of the brace member) of the overlapped brace member j should be taken as equal to that of the overlapping brace member. $\langle AC2 \rangle$ See also Table 7.8. $\langle AC2 \rangle$	

Table 7.11: Design axial resistances of welded T, X and Y joints between RHS or CHS braces and RHS chords

AC2

Type of joint	Design resistance
	Chord face failure $\beta \leq 0,85$
	$N_{1,Rd} = \frac{k_n f_{y0} t_0^2}{(1 - \beta) \sin \theta_1} \left(\frac{2\eta}{\sin \theta_1} + 4\sqrt{1 - \beta} \right) / \gamma_{M5}$
	Chord side wall buckling ¹⁾ $\beta = 1,0$ ²⁾
	$N_{1,Rd} = \frac{k_n f_b t_0}{\sin \theta_1} \left(\frac{2h_1}{\sin \theta_1} + 10t_0 \right) / \gamma_{M5}$
	Brace failure $\beta \geq 0,85$
	$N_{1,Rd} = f_{yt} t_1 (2h_1 - 4t_1 + 2b_{eff}) / \gamma_{M5}$
Punching shear $0,85 \leq \beta \leq (1 - 1/\gamma)$	
$N_{1,Rd} = \frac{f_{y0} t_0}{\sqrt{3} \sin \theta_1} \left(\frac{2h_1}{\sin \theta_1} + 2b_{c,p} \right) / \gamma_{M5}$	
¹⁾ For X joints with $\cos \theta_1 > h_1/h_0$ use the smaller of this value and the design shear resistance of the chord side walls given for K and N gap joints in Table 7.12.	
²⁾ For $0,85 \leq \beta \leq 1,0$ use linear interpolation between the value for chord face failure at $\beta = 0,85$ and the governing value for chord side wall failure at $\beta = 1,0$ (side wall buckling or chord shear).	
For circular braces, multiply the above resistances by $\pi/4$, replace b_1 and h_1 by d_1 and replace b_2 and h_2 by d_2 .	
For tension: $f_b = f_{y0}$	$b_{eff} = \frac{10}{b_0/t_0} \frac{f_{y0} t_0}{f_{yt} t_1} b_1 \quad \text{but } b_{eff} \leq b_1$
For compression: $f_b = \chi f_{y0}$ (T and Y joints) $f_b = 0,8 \chi f_{y0} \sin \theta_1$ (X joints)	$b_{c,p} = \frac{10}{b_0/t_0} b_1 \quad \text{but } b_{c,p} \leq b_1$
where χ is the reduction factor for flexural buckling obtained from EN 1993-1-1 using the relevant buckling curve and a normalized slenderness $\bar{\lambda}$ determined from: $\bar{\lambda} = 3,46 \frac{\left(\frac{h_0}{t_0} - 2 \right) \sqrt{\frac{1}{\sin \theta_1}}}{\pi \sqrt{\frac{E}{f_{y0}}}}$	For $n > 0$ (compression): $k_n = 1,3 - \frac{0,4n}{\beta}$ but $k_n \leq 1,0$ For $n \leq 0$ (tension): $k_n = 1,0$

AC2

Table 7.12: Design axial resistances of welded K and N joints between RHS or CHS braces and RHS chords

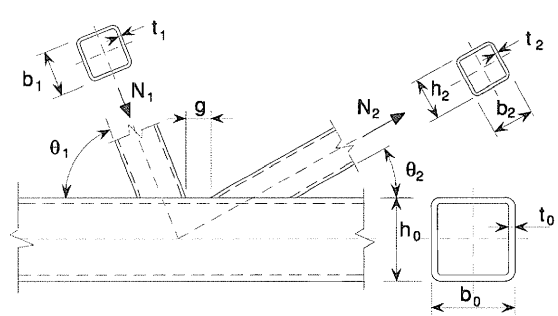
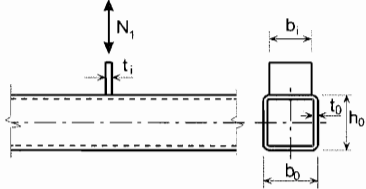
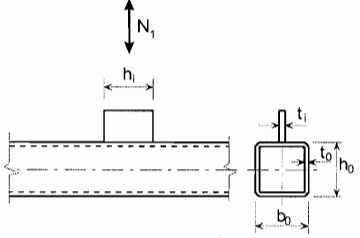
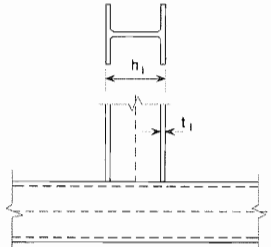
Type of joint	Design resistance [$i = 1$ or 2]
K and N gap joints	Chord face failure
	$N_{i,Rd} = \frac{8,9k_n f_{y0} t_0^2 \sqrt{\gamma}}{\sin \theta_i} \left(\frac{b_1 + b_2 + h_1 + h_2}{4b_0} \right) / \gamma_{M5}$
	Chord shear
	$N_{i,Rd} = \frac{f_{y0} A_v}{\sqrt{3} \sin \theta_i} / \gamma_{M5}$
	$N_{0,Rd} = \left[(A_0 - A_v) f_{y0} + A_v f_{y0} \sqrt{1 - (V_{Ed} / V_{pl,Rd})^2} \right] / \gamma_{M5}$
	Brace failure
	$N_{i,Rd} = f_{yt_i} (2h_i - 4t_i + b_i + b_{eff}) / \gamma_{M5}$
	Punching shear $\beta \leq (1 - 1/\gamma)$
$N_{i,Rd} = \frac{f_{y0} t_0}{\sqrt{3} \sin \theta_i} \left(\frac{2h_i}{\sin \theta_i} + b_i + b_{e,p} \right) / \gamma_{M5}$	
K and N overlap joints	As in Table 7.10.
For circular braces, multiply the above resistances by $\pi/4$, replace b_1 and h_1 by d_1 and replace b_2 and h_2 by d_2 , except for chord shear. AC2	
$A_v = (2h_0 + ab_0)t_0$ For a square or rectangular brace member: $\alpha = \sqrt{\frac{1}{1 + \frac{4g^2}{3t_0^2}}}$ where g is the gap, see Figure 1.3(a). AC2 For circular brace members: $\alpha = 0$ AC2	$b_{eff} = \frac{10}{b_0/t_0} \frac{f_{y0} t_0}{f_{yt_i}} b_i \quad \text{but } b_{eff} \leq b_i$
	$\text{AC2 } b_{c,p} = \frac{10}{b_0/t_0} b_i \text{ AC2} \quad \text{but } b_{c,p} \leq b_i$
	For $n > 0$ (compression): $k_n = 1,3 - \frac{0,4n}{\beta}$ but $k_n \leq 1,0$ For $n \leq 0$ (tension): $k_n = 1,0$

Table 7.13: Design resistances of welded joints connecting gusset plates or I or H sections to RHS members

Transverse plate	$\langle AC2 \rangle$ Chord face failure $\beta \leq 0,85 \langle AC2 \rangle$
	$\langle AC2 \rangle N_{1,Rd} = k_n f_{y0} t_0^2 \frac{2 + 2,8\beta}{\sqrt{1 - 0,9\beta}} / \gamma_{M5} \quad * \langle AC2 \rangle$
	Chord side wall crushing when $b_1 \geq b_0 - 2t_0$
	$\langle AC2 \rangle N_{1,Rd} = k_n f_{y0} t_0 (2t_1 + 10t_0) / \gamma_{M5} \quad \langle AC2 \rangle$
	Punching shear when $b_1 \leq b_0 - 2t_0$
	$N_{1,Rd} = \frac{f_{y0} t_0}{\sqrt{3}} (2t_1 + 2b_{e,p}) / \gamma_{M5}$
Longitudinal plate	Chord face failure
	$\langle AC2 \rangle$ $N_{1,Rd} = k_m f_{y0} t_0^2 (2h_1 / b_0 + 4\sqrt{1 - t_1 / b_0}) / \gamma_{M5} \quad \langle AC2 \rangle$
$t_1 / b_0 \leq 0,2$	
I or H section	
	<p>As a conservative approximation, if $\eta \geq 2\sqrt{1 - \beta}$, $N_{1,Rd}$ for an I or H section may be assumed to be equal to the design resistance of two transverse plates of similar dimensions to the flanges of the I or H section, determined as specified above.</p> <p>If $\eta < 2\sqrt{1 - \beta}$, a linear interpolation between one and two plates should be made.</p> $M_{ip,I,Rd} = N_{1,Rd} (h_1 - t_1)$ <p>$\langle AC2 \rangle N_{1,Rd}$ is the capacity of one flange; β is the ratio of the width of the flange of the I or H brace section and the width of the RHS chord. $\langle AC2 \rangle$</p>
Range of validity	
In addition to the limits given in Table 7.8: $0,5 \leq \beta \leq 1,0$ $b_0 / t_0 \leq 30$	
Parameters b_{eff} , $b_{e,p}$ and k_m	
$b_{eff} = \frac{10}{b_0 / t_0} \frac{f_{y0} t_0}{f_{y1} t_1} b_1$ but $b_{eff} \leq b_1$	For $n > 0$ (compression): $k_m = 1,3(1 - n)$ but $k_m \leq 1,0$
$b_{e,p} = \frac{10}{b_0 / t_0} b_1$ but $b_{e,p} \leq b_1$	For $n \leq 0$ (tension): $k_m = 1,0$
*)	Fillet welded connections should be designed in accordance with 4.10.

- (5) Brace member connections subjected to combined bending and axial force should satisfy the following requirement:

$$\frac{N_{i,Ed}}{N_{i,Rd}} + \frac{M_{ip,i,Ed}}{M_{ip,i,Rd}} + \frac{M_{op,i,Ed}}{M_{op,i,Rd}} \leq 1,0 \quad \dots (7.4)$$

where:

$M_{ip,i,Rd}$ is the design in-plane moment resistance

$M_{ip,i,Ed}$ is the design in-plane internal moment

$M_{op,i,Rd}$ is the design out-of-plane moment resistance

$M_{op,i,Ed}$ is the design out-of-plane internal moment

- (6) The design internal moment $M_{i,Ed}$ may be taken as the value at the point where the centreline of the brace member meets the face of the chord member.
- (7) For unreinforced joints, the design in-plane moment resistance and design out-of-plane moment resistance $M_{i,Rd}$ should be obtained from Table 7.13 or Table 7.14 as appropriate. For reinforced joints see 7.5.2.2.
- (8) The special types of welded joints indicated in Table 7.15 and Table 7.16 should satisfy the appropriate design criteria specified for each type in that table.

7.5.2.2 Reinforced joints

- (1) Various types of joint reinforcement may be used. The appropriate type depends upon the failure mode that, in the absence of reinforcement, governs the design resistance of the joint.
- (2) Flange reinforcing plates may be used to increase the resistance of the joint to chord face failure, punching shear failure or brace failure with reduced effective width.
- (3) A pair of side plates may be used to reinforce a joint against chord side wall failure or chord shear failure.
- (4) In order to avoid partial overlapping of brace members in a K or N joint, the brace members may be welded to a vertical stiffener.
- (5) Any combinations of these types of joint reinforcement may also be used.
- (6) The grade of steel used for the reinforcement should not be lower than that of the chord member.
- (7) The design resistances of reinforced joints should be determined using Table 7.17 and Table 7.18.

Table 7.14: Design resistance moments of welded joints between RHS brace members and RHS chords

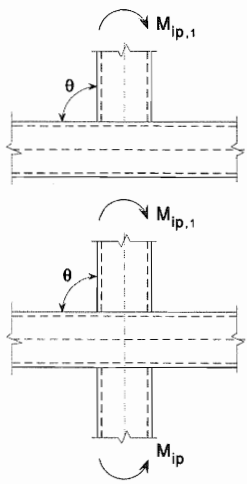
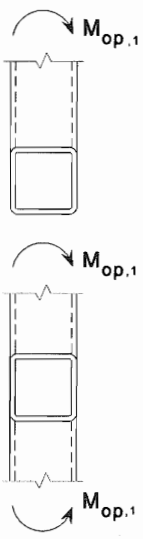
T and X joints	Design resistance
In-plane moments ($\theta = 90^\circ$)	Chord face failure $\beta \leq 0,85$
	$M_{ip,1,Rd} = k_n f_{y0} t_0^2 h_1 \left(\frac{1}{2\eta} + \frac{2}{\sqrt{1-\beta}} + \frac{\eta}{1-\beta} \right) / \gamma_{M5}$
	Chord side wall crushing $\text{AC2} \ 0,85 < \beta \leq 1,0 \ \text{AC2}$
	$M_{ip,1,Rd} = 0,5 f_{yk} t_0 (h_1 + 5t_0)^2 / \gamma_{M5}$ $f_{yk} = f_{y0} \quad \text{for T joints}$ $f_{yk} = 0,8 f_{y0} \quad \text{for X joints}$
	Brace failure $\text{AC2} \ 0,85 < \beta \leq 1,0 \ \text{AC2}$
	$\text{AC2} \ M_{ip,1,Rd} = f_{y1} (W_{pl,1} - (1 - b_{eff} / b_1) b_1 (h_1 - t_1) t_1) / \gamma_{M5} \ \text{AC2}$
Out-of-plane moments ($\theta = 90^\circ$)	Chord face failure $\beta \leq 0,85$
	$M_{op,1,Rd} = k_n f_{y0} t_0^2 \left(\frac{h_1(1+\beta)}{2(1-\beta)} + \sqrt{\frac{2b_0 b_1(1+\beta)}{1-\beta}} \right) / \gamma_{M5}$
	Chord side wall crushing $\text{AC2} \ 0,85 < \beta \leq 1,0 \ \text{AC2}$
	$M_{op,1,Rd} = f_{yk} t_0 (b_0 - t_0) (h_1 + 5t_0) / \gamma_{M5}$ $f_{yk} = f_{y0} \quad \text{for T joints}$ $f_{yk} = 0,8 f_{y0} \quad \text{for X joints}$
	Chord distortional failure (T joints only) *)
	$M_{op,1,Rd} = 2 f_{y0} t_0 (h_1 t_0 + \sqrt{b_0 h_0 t_0 (b_0 + h_0)}) / \gamma_{M5}$
	Brace failure $\text{AC2} \ 0,85 < \beta \leq 1,0 \ \text{AC2}$
	$M_{op,1,Rd} = f_{y1} (W_{pl,1} - 0,5(1 - b_{eff} / b_1)^2 b_1^2 t_1) / \gamma_{M5}$
Parameters b_{eff} and k_n	
$b_{eff} = \frac{10}{b_0 / t_0} \frac{f_{y0} t_0}{f_{y1} t_1} b_1$ <p>but $b_{eff} \leq b_1$</p>	<p>For $n > 0$ (compression):</p> $k_n = 1,3 - \frac{0,4n}{\beta}$ <p>but $k_n \leq 1,0$</p> <p>For $n \leq 0$ (tension):</p> $k_n = 1,0$
*) This criterion does not apply where chord distortional failure is prevented by other means.	

Table 7.15: Design criteria for special types of welded joints between RHS brace members and RHS chords

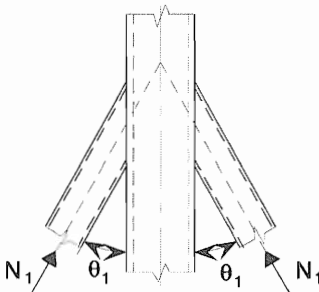
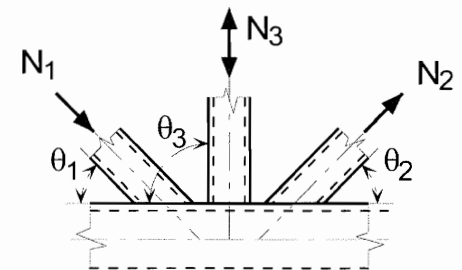
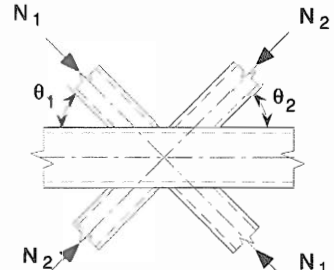
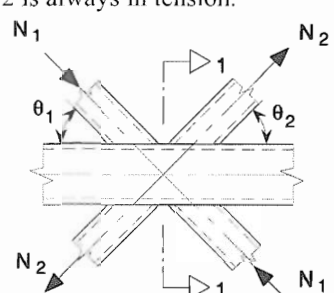
Type of joint	Design criteria
<p>The members may be in either tension or compression and should act as in the same direction for both members.</p> 	$N_{1,Ed} \leq N_{1,Rd}$ <p>where $N_{1,Rd}$ is the value of $N_{1,Rd}$ for an X joint from Table 7.11.</p>
<p>The member 1 is always in compression and member 2 is always in tension.</p> 	$N_{1,Ed} \sin \theta_1 + N_{3,Ed} \sin \theta_3 \leq N_{1,Rd} \sin \theta_1$ $N_{2,Ed} \sin \theta_2 \leq N_{1,Rd} \sin \theta_1$ <p>where $N_{1,Rd}$ is the value of $N_{1,Rd}$ for a K joint from Table 7.12, but with $\frac{b_1 + b_2 + h_1 + h_2}{4b_0}$</p> <p>replaced by: $\frac{b_1 + b_2 + b_3 + h_1 + h_2 + h_3}{6b_0}$</p>
<p>All bracing members should be either compression or tension.</p> 	$N_{1,Ed} \sin \theta_1 + N_{2,Ed} \sin \theta_2 \leq N_{x,Rd} \sin \theta_x$ <p>where $N_{x,Rd}$ is the value of $N_{x,Rd}$ for an X joint from Table 7.11, and $N_{x,Rd} \sin \theta_x$ is the larger of:</p> $ N_{1,Rd} \sin \theta_1 \quad \text{and} \quad N_{2,Rd} \sin \theta_2 $
<p>Member 1 is always in compression and member 2 is always in tension.</p> 	$N_{i,Ed} \leq N_{i,Rd}$ <p>where $N_{i,Rd}$ is the value of $N_{i,Rd}$ for a K joint from Table 7.12, provided that, in a gap-type joint, at section 1-1 the chord satisfies:</p> $\left[\frac{N_{0,Ed}}{N_{pl,0,Rd}} \right]^2 + \left[\frac{V_{0,Ed}}{V_{pl,0,Rd}} \right]^2 \leq 1,0$

Table 7.16: Design criteria for welded knee joints and cranked-chord joints in RHS members

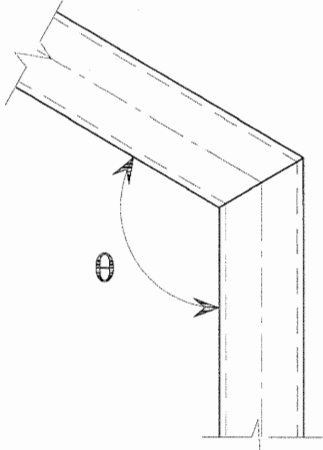
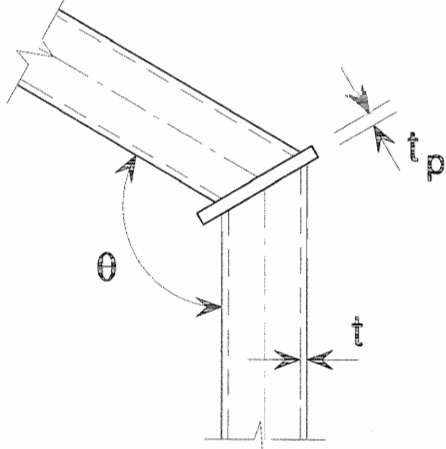
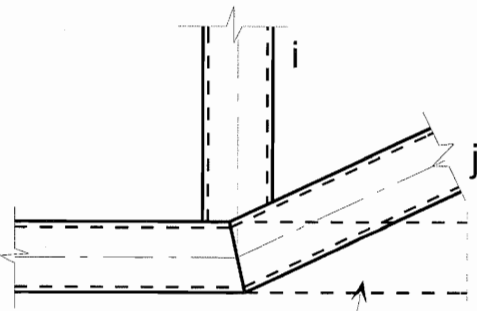
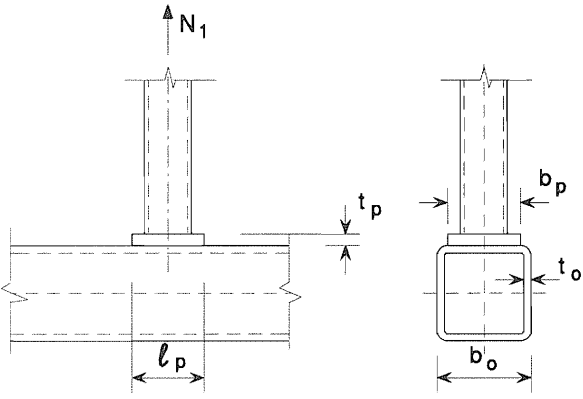
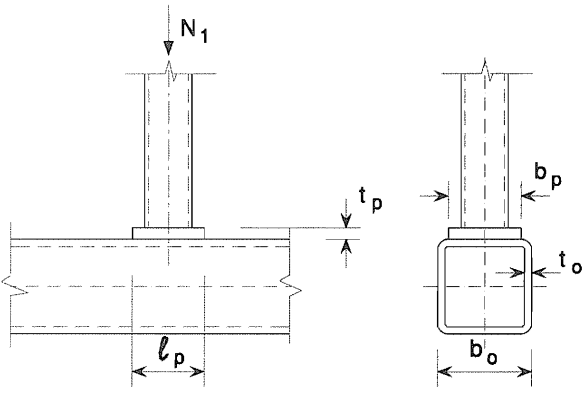
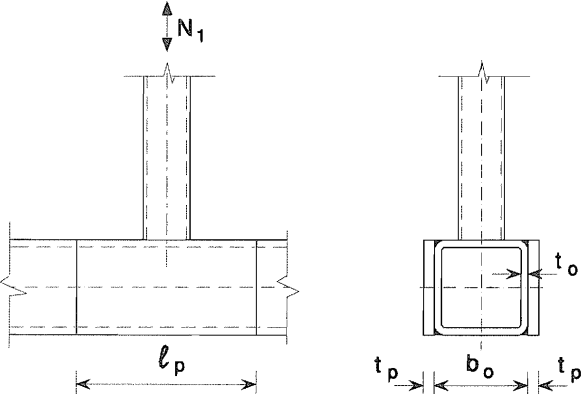
Type of joint	Criteria
Welded knee joints	
	<p>The cross-section should be Class 1 for pure bending, see EN 1993-1-1.</p> $N_{Ed} \leq 0,2N_{pl,Rd}$ <p>and</p> $\frac{N_{Ed}}{N_{pl,Rd}} + \frac{M_{Ed}}{M_{pl,Rd}} \leq \kappa$ <p>If $\theta \leq 90^\circ$:</p> $\kappa = \frac{3\sqrt{b_0/h_0}}{[b_0/t_0]^{0,8}} + \frac{1}{1+2b_0/h_0}$ <p>If $90^\circ < \theta \leq 180^\circ$:</p> $\kappa = 1 - (\sqrt{2} \cos(\theta/2))(1 - \kappa_{90})$ <p>where κ_{90} is the value of κ for $\theta = 90^\circ$.</p>
	$t_p \geq 1,5t \quad \text{and} \quad \geq 10 \text{ mm}$ $\frac{N_{Ed}}{N_{pl,Rd}} + \frac{M_{Ed}}{M_{pl,Rd}} \leq 1,0$
Cranked-chord	
 <p>Imaginary extension of chord</p>	$N_{i,Ed} \leq N_{i,Rd}$ <p>where $N_{i,Rd}$ is the value of $N_{i,Rd}$ for a K or N overlap joint from Table 7.12.</p>

Table 7.17: Design resistances of reinforced welded T, Y and X joints between RHS or CHS brace members and RHS chords

AC2

Type of joint	Design resistance
Reinforced with flange plates to avoid chord face failure, brace failure or punching shear.	
Tension loading $\beta_p \leq 0,85$	
	$l_p \geq \frac{h_1}{\sin \theta_1} + \sqrt{b_p (b_p - b_1)}$ <p>and</p> $b_p \geq b_0 - 2t_0$ $t_p \geq 2t_1$ $N_{1,Rd} = \frac{f_{yp} t_p^2}{(1 - b_1 / b_p) \sin \theta_1} \dots$ $\dots \cdot \left(\frac{2h_1 / b_p}{\sin \theta_1} + 4\sqrt{1 - b_1 / b_p} \right) / \gamma_{M5}$
Compression loading $\beta_p \leq 0,85$	
	$l_p \geq \frac{h_1}{\sin \theta_1} + \sqrt{b_p (b_p - b_1)}$ <p>and</p> $b_p \geq b_0 - 2t_0$ $t_p \geq 2t_1$ <p>Take $N_{1,Rd}$ as the value of $N_{1,Rd}$ for a T, X or Y joint from Table 7.11, but with $k_n = 1,0$ and t_0 replaced by t_p for chord face failure, brace failure and punching shear only.</p>
Reinforced with side plates to avoid chord side wall buckling or chord side wall shear.	
	$l_p \geq 1,5h_1 / \sin \theta_1$ $t_p \geq 2t_1$ <p>Take $N_{1,Rd}$ as the value of $N_{1,Rd}$ for a T, X or Y joint from Table 7.11, but with t_0 replaced by $(t_0 + t_p)$ for chord side wall buckling failure and chord side wall shear failure only.</p>

AC2

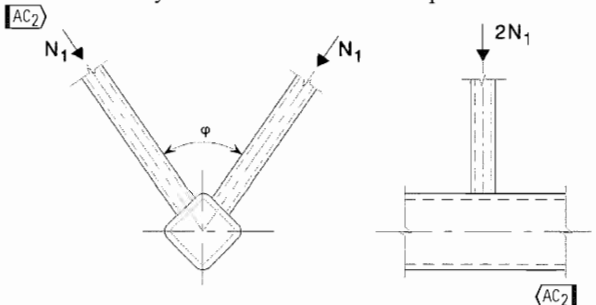
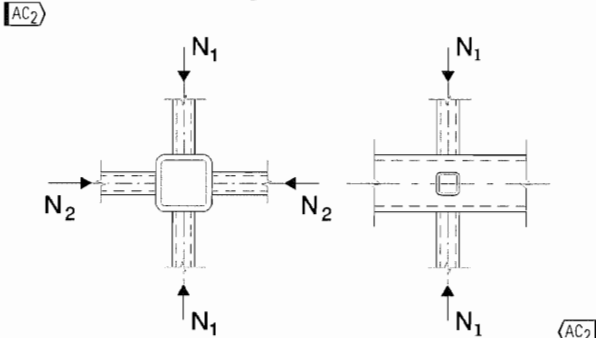
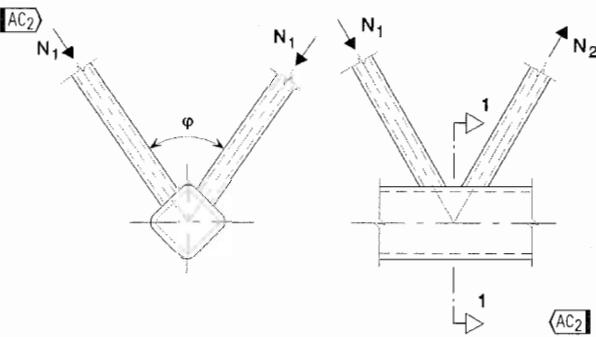
Table 7.18: Design resistances of reinforced welded K and N joints between RHS or CHS brace members and RHS chords

Type of joint	Design resistance [$i = 1$ or 2]
Reinforced with flange plates to avoid chord face failure, brace failure or punching shear.	
	$\ell_p \geq 1,5 \left(\frac{h_1}{\sin \theta_1} + g + \frac{h_2}{\sin \theta_2} \right)$ $b_p \geq b_0 - 2t_0$ $t_p \geq 2t_1 \text{ and } 2t_2$ <p>Take $N_{i,Rd}$ as the value of $N_{i,Rd}$ for a K or N joint from Table 7.12, but with t_0 replaced by t_p for chord face failure, brace failure and punching shear only.</p>
Reinforced with a pair of side plates to avoid chord shear failure.	
	$\ell_p \geq 1,5 \left(\frac{h_1}{\sin \theta_1} + g + \frac{h_2}{\sin \theta_2} \right)$ <p>Take $N_{i,Rd}$ as the value of $N_{i,Rd}$ for a K or N joint from Table 7.12, but with t_0 replaced by $(t_0 + t_p)$ for chord shear failure only.</p>
Reinforced by a division plate between the brace members because of insufficient overlap.	
	$t_p \geq 2t_1 \text{ and } 2t_2$ <p>Take $N_{i,Rd}$ as the value of $N_{i,Rd}$ for a K or N overlap joint from Table 7.12 with $\lambda_{ov} < 80\%$, but with b_j, t_j and f_{yj} replaced by b_p, t_p and f_{yp} in the expression for $b_{c,ov}$ given in Table 7.10.</p>

7.5.3 Multiplanar joints

- (1) In each relevant plane of a multiplanar joint, the design criteria given in 7.5.2 should be satisfied using the reduced design resistances obtained from 7.5.3(2).
- (2) The design resistances for each relevant plane of a multiplanar joint should be determined by applying the appropriate reduction factor μ given in Table 7.19 to the resistance of the corresponding uniplanar joint calculated according to 7.5.2 with the appropriate chord load in the multiplanar situation.

Table 7.19: Reduction factors for multiplanar joints

Type of joint	Reduction factor μ
<p>TT joint</p> <p>Member 1 may be either tension or compression.</p>  <p>AC2</p>	<p>$60^\circ \leq \varphi \leq 90^\circ$</p> <p>$\mu = 0,9$</p>
<p>XX joint</p> <p>Members 1 and 2 can be either in compression or tension. $N_{2,Ed}/N_{1,Ed}$ is negative if one member is in tension and one in compression.</p>  <p>AC2</p>	<p>$\mu = 0,9(1 + 0,33N_{2,Ed} / N_{1,Ed})$</p> <p>taking account of the sign of $N_{1,Ed}$ and $N_{2,Ed}$</p> <p>where $N_{2,Ed} \leq N_{1,Ed}$</p>
<p>KK joint</p>  <p>AC2</p>	<p>$60^\circ \leq \varphi \leq 90^\circ$</p> <p>$\mu = 0,9$</p> <p>provided that, in a gap-type joint, at section 1-1 the chord satisfies:</p> $\left[\frac{N_{0,Ed}}{N_{pl,0,Rd}} \right]^2 + \left[\frac{V_{0,Ed}}{V_{pl,0,Rd}} \right]^2 \leq 1,0$

7.6 Welded joints between CHS or RHS brace members and I or H section chords

- (1) Provided that the geometry of the joints is within the range of validity given in Table 7.20, the design resistances of the joints should be determined using the expressions given in Table 7.21 or Table 7.22 as appropriate.

Table 7.20: Range of validity for welded joints between CHS or RHS brace members and I or H section chord members

Type of joint	Joint parameter [$i = 1$ or 2 , $j =$ overlapped brace]					
	d_w/t_w	b_i/t_i and h_i/t_i or d_i/t_i		h_i/b_i	b_0/t_f	b_i/b_j
		Compression	Tension			
X	Class 1 and $d_w \leq 400$ mm	$\overline{AC2}$ Class 1 or 2 and $\overline{AC2}$ $\frac{h_i}{t_i} \leq 35$	$\frac{h_i}{t_i} \leq 35$	$\geq 0,5$ but $\leq 2,0$		—
T or Y	$\overline{AC2}$ Class 1 or 2 and $\overline{AC2}$ $d_w \leq 400$ mm	$\overline{AC2}$ $\frac{h_i}{t_i} \leq 35$ $\frac{b_i}{t_i} \leq 35$ $\frac{d_i}{t_i} \leq 50$	$\frac{b_i}{t_i} \leq 35$ $\frac{d_i}{t_i} \leq 50$	1,0	$\overline{AC2}$ Class 1 or 2 $\overline{AC2}$	—
K gap						
N gap						
K overlap						$\geq 0,5$ but $\leq 2,0$
N overlap						

$\overline{AC2}$ ¹⁾ $\lambda_{ov,lim.} = 60\%$ if the hidden seam is not welded and 80% if the hidden seam is welded. If the overlap exceeds $\lambda_{ov,lim.}$ or if the braces are rectangular sections with $h_i < b_i$ and/or $h_j < b_j$, the connection between the braces and chord face has to be checked for shear. $\overline{AC2}$

- (2) For joints within the range of validity given in Table 7.20, only $\overline{AC2}$ the failure modes covered in $\overline{AC2}$ the appropriate table need be considered. The design resistance of a connection should be taken as the minimum value for all applicable criteria.
- (3) For joints outside the range of validity given in Table 7.20, $\overline{AC2}$ all the failure modes given in $\overline{AC2}$ 7.2.2 should be considered. In addition, the secondary moments in the joints caused by their rotational stiffness should be taken into account.
- (4) In brace member connections subjected only to axial forces, the design axial force $N_{i,Ed}$ should not exceed the design axial resistance of the welded joint $N_{i,Rd}$, determined from Table 7.21.
- (5) Brace member connections subject to combined bending and axial force should satisfy:

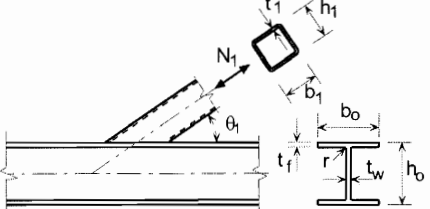
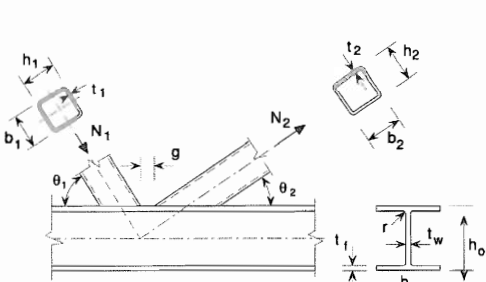
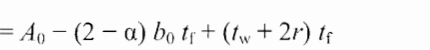
$$\frac{N_{i,Ed}}{N_{i,Rd}} + \frac{M_{ip,i,Ed}}{M_{ip,i,Rd}} \leq 1,0 \quad \dots (7.5)$$

where:

$M_{ip,i,Rd}$ is the design in-plane moment resistance;

$M_{ip,i,Ed}$ is the design in-plane internal moment.

Table 7.21: Design resistances of welded joints between RHS or CHS brace members and I or H section chords

Type of joint	Design resistance [$i = 1$ or 2 , $j =$ overlapped brace]
T, Y and X joints	Chord web yielding
	$N_{i,Rd} = \frac{f_{y0} t_w b_w}{\sin \theta_1} / \gamma_{M5}$
	Brace failure
	$N_{i,Rd} = 2 f_{y1} t_1 p_{eff} / \gamma_{M5}$
K and N gap joints [$i = 1$ or 2]	$N_{i,Rd} = \frac{f_{y0} t_w b_w}{\sin \theta_1} / \gamma_{M5}$
	<p>Brace failure need not be checked if: $g/t_f \leq 20 - 28\beta$; $\beta \leq 1,0 - 0,03\gamma$ where $\gamma = b_0/2t_f$ and for CHS: $0,75 \leq d_1/d_2 \leq 1,33$ or for RHS: $0,75 \leq b_1/b_2 \leq 1,33$</p>
K and N overlap joints *) [$i = 1$ or 2]	Chord shear
	$N_{i,Rd} = \frac{f_{y0} A_v}{\sqrt{3} \sin \theta_i} / \gamma_{M5}$
	$N_{0,Rd} = \left[(A_0 - A_v) f_{y0} + A_v f_{y0} \sqrt{1 - (V_{Ed} / V_{pl,Rd})^2} \right] / \gamma_{M5}$
Members i and j may be in either tension or compression.	$N_{i,Rd} = f_{yi} t_i (p_{eff} + b_{e,ov} + 2h_i \frac{\lambda_{ov}}{50} - 4t_i) / \gamma_{M5}$
	Brace failure $25\% \leq \lambda_{ov} < 50\%$
	$N_{i,Rd} = f_{yi} t_i (p_{eff} + b_{e,ov} + 2h_i - 4t_i) / \gamma_{M5}$
	Brace failure $50\% \leq \lambda_{ov} < 80\%$
	$N_{i,Rd} = f_{yi} t_i (b_i + b_{e,ov} + 2h_i - 4t_i) / \gamma_{M5}$
	Brace failure $\lambda_{ov} \geq 80\%$
$A_v = A_0 - (2 - \alpha) b_0 t_f + (t_w + 2r) t_f$	$p_{eff} = t_w + 2r + 7t_f f_{y0} / f_{yi}$
For RHS brace: $\alpha = \sqrt{\frac{1}{(1 + 4g^2 / (3t_f^2))}}$	<p>but for T, Y, X joints and K and N gap joints: $p_{eff} \leq b_i + h_i - 2t_i$ but for K and N overlap joints: $p_{eff} \leq b_i$</p>
For CHS brace: $\alpha = 0$	$b_{e,ov} = \frac{10 f_{yj} t_j b_i}{b_j / t_j f_{yi} t_i}$
	<p>but $b_{e,ov} \leq b_i$</p> $b_w = \frac{h_i}{\sin \theta_i} + 5(t_f + r)$ <p>but</p> $b_w \leq 2t_i + 10(t_f + r)$
For CHS braces multiply the above resistances for brace failure by $\pi/4$ and replace both b_1 and h_1 by d_1 and both b_2 and h_2 by d_2 , except for chord shear.	
*) Only the overlapping brace member i need be checked. The efficiency (i.e. the design resistance of the joint divided by the design plastic resistance of the brace member) of the overlapped brace member j should be taken as equal to that of the overlapping brace member. See also Table 7.20.	

- (6) The design internal moment $M_{i,Ed}$ may be taken as the value at the point where the centreline of the brace member meets the face of the chord member.
- (7) The design in-plane moment resistance $M_{ip,1,Rd}$ should be obtained from Table 7.22.
- (8) If stiffeners in the chord (see Figure 7.7) are used, then the $\boxed{AC2}$ design brace failure resistance $\boxed{AC2}$ $N_{i,Rd}$ for T-, X-, Y-, K-gap and N-gap joints (Table 7.22) is determined as follows:

$$N_{i,Rd} = 2 f_{yi} t_i (b_{eff} + b_{eff,s}) / \gamma_{M5} \quad \dots (7.6)$$

where:

$$b_{eff} = t_w + 2r + 7 t_f f_{y0} / f_{yi} \quad \text{but} \quad \leq b_i + h_i - 2t_i$$

$$b_{eff,s} = t_s + 2a + 7 t_f f_{y0} / f_{yi} \quad \text{but} \quad \leq b_i + h_i - 2t_i$$

$$b_{eff} + b_{eff,s} \leq b_i + h_i - 2t_i$$

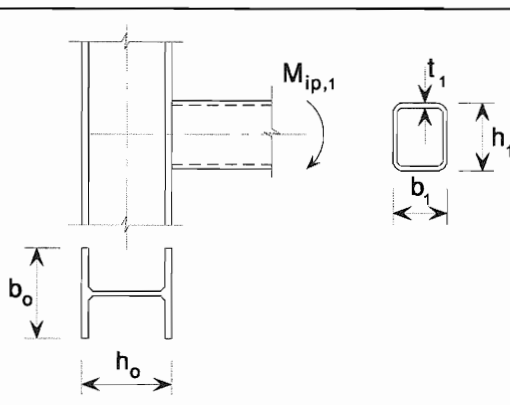
where:

a is stiffener weld throat thickness, ' $2a$ ' becomes ' a ' if single sided fillet welds are used;

s refers to the stiffener.

- (9) The stiffeners should be at least as thick as the I-section web.

Table 7.22: Design moment resistances of welded joints between rectangular hollow section brace members and I or H section chords

Type of joint	Design resistance [$i = 1$ or $2, j =$ overlapped brace]
T and Y joints	Chord web yielding
	$\boxed{AC2} M_{ip,1,Rd} = 0,5 f_{y0} t_w b_w (h_1 - t_1) / \gamma_{M5} \boxed{AC2}$
	Brace failure
$\boxed{AC2}$ Parameters p_{eff} and $b_w \boxed{AC2}$	
$\boxed{AC2} p_{eff} = t_w + 2r + 7 t_f f_{y0} / f_{y1} \quad \text{but} \quad p_{eff} \leq b_1 + h_1 - 2t_1$ $\boxed{AC2}$	$b_w = \frac{h_1}{\sin \theta_1} + 5(t_f + r) \quad \text{but} \quad b_w \leq 2t_1 + 10(t_f + r)$

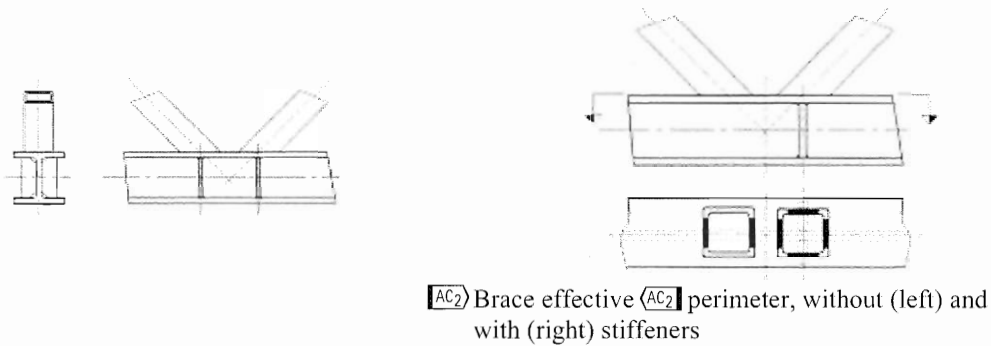


Figure 7.7: Stiffeners for I-section chords

7.7 Welded joints between CHS or RHS brace members and channel section chord members

- (1) Provided that the geometry of the joints is within the range of validity given in Table 7.23, the design resistances of welded joints between hollow section brace members and channel section chord members may be determined using Table 7.24.
- (2) The secondary moments in the joints caused by their bending stiffness should be taken into account.
- (3) In a gap type joint, the design axial resistance of the chord cross-section $N_{0,Rd}$ should be determined allowing for the shear force transferred between the brace members by the chord, neglecting the associated secondary moment. Verification should be made according to EN 1993-1-1.

Table 7.23: Range of validity for welded joints between CHS or RHS brace members and channel section chord

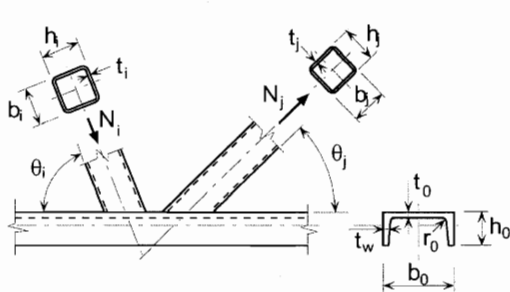
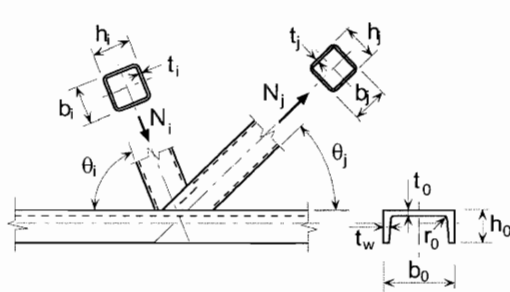
Type of joint	Joint parameter [$i = 1$ or 2 , $j =$ overlapped brace]					
	b_i/b_0	b_i/t_i and h_i/t_i or d_i/t_i		h_i/b_i	b_0/t_0	Gap or overlap b_i/b_j
		Compression	Tension			
K gap N gap	$\geq 0,4$ and $b_0 \leq 400$ mm	[AC2] Class 1 or 2 and [AC2] $\frac{h_i}{t_i} \leq 35$	$\frac{h_i}{t_i} \leq 35$	$\geq 0,5$ but $\leq 2,0$	[AC2] Class 1 or 2 [AC2]	$0,5(1-\beta^*) \leq g/b_0^* \leq 1,5(1-\beta^*)$ ¹⁾ and $g \geq t_1 + t_2$
K overlap N overlap	$\geq 0,25$ and $b_0 \leq 400$ mm	$\frac{b_i}{t_i} \leq 35$ $\frac{d_i}{t_i} \leq 50$	$\frac{b_i}{t_i} \leq 35$ $\frac{d_i}{t_i} \leq 50$			[AC2] $25\% \leq \lambda_{ov} \leq \lambda_{ov,lim.}$ ²⁾ [AC2] $b_i/b_j \geq 0,75$

$\beta^* = b_1/b_0^*$
 $b_0^* = b_0 - 2(t_w + r_0)$

¹⁾ This condition only apply when $\beta \leq 0,85$.

[AC2] ²⁾ $\lambda_{ov,lim.} = 60\%$ if the hidden seam is not welded and 80% if the hidden seam is welded. If the overlap exceeds $\lambda_{ov,lim.}$ or if the braces are rectangular sections with $h_i < b_i$ and/or $h_j < b_j$, the connection between the braces and chord face has to be checked for shear. [AC2]

Table 7.24: Design resistance of welded joints between RHS or CHS brace members and channel section chords

Type of joint	Design resistance [$i = 1$ or 2 , $j =$ overlapped brace]
K and N gap joints	Brace failure
	$N_{i,Rd} = f_{yi} t_i (b_i + b_{eff} + 2h_i - 4t_i) / \gamma_{M5}$
	Chord failure
	$N_{i,Rd} = \frac{f_{y0} A_v}{\sqrt{3} \sin \theta_i} / \gamma_{M5}$ $N_{0,Rd} = \left[(A_0 - A_v) f_{y0} + A_v f_{y0} \sqrt{1 - (V_{Ed} / V_{pl,Rd})^2} \right] / \gamma_{M5}$
K and N overlap joints ^{*)}	Brace failure $25\% \leq \lambda_{ov} < 50\%$
	$\boxed{AC2} \quad N_{i,Rd} = f_{yi} t_i (b_{eff} + b_{e,ov} + 2h_i \frac{\lambda_{ov}}{50} - 4t_i) / \gamma_{M5} \quad \boxed{AC2}$
	Brace failure $50\% \leq \lambda_{ov} < 80\%$
	$N_{i,Rd} = f_{yi} t_i (b_{eff} + b_{e,ov} + 2h_i - 4t_i) / \gamma_{M5}$
	Brace failure $\lambda_{ov} \geq 80\%$
	$N_{i,Rd} = f_{yi} t_i (b_i + b_{e,ov} + 2h_i - 4t_i) / \gamma_{M5}$
$A_v = A_0 - (1 - \alpha) b_0^* t_0$ $b_0^* = b_0 - 2(t_w + r_0)$ <p>For RHS: $\alpha = \sqrt{\frac{1}{1 + 4g^2 / 3t_f^2}}$</p> <p>For CHS: $\alpha = 0$</p> $V_{pl,Rd} = \frac{f_{y0} A_v}{\sqrt{3}} / \gamma_{M5}$ $V_{Ed} = (N_{i,Ed} \sin \theta_i)_{max}$	$b_{eff} = \frac{10}{b_0^* / t_0} \frac{f_{y0} t_0}{f_{yi} t_i} b_i \quad \text{but } b_{eff} \leq b_i$ $b_{e,ov} = \frac{10}{b_j / t_j} \frac{f_{yj} t_j}{f_{yi} t_i} b_i \quad \text{but } b_{e,ov} \leq b_i$
For CHS braces $\boxed{AC2}$ except for the chord shear $\boxed{AC2}$, multiply the above resistances by $\pi/4$ and replace both b_1 and h_1 by d_1 as well as b_2 and h_2 by d_2 .	
*) Only the overlapping brace member i needs to be checked. The efficiency (i.e. the design resistance of the joint divided by the design plastic resistance of the brace member) of the overlapped brace member j should be taken as equal to that of the overlapping brace member.	