

The European Union

EDICT OF GOVERNMENT

In order to promote public education and public safety, equal justice for all, a better informed citizenry, the rule of law, world trade and world peace, this legal document is hereby made available on a noncommercial basis, as it is the right of all humans to know and speak the laws that govern them.

EN 1993-1-2 (2005) (English): Eurocode 3: Design of steel structures - Part 1-2: General rules - Structural fire design [Authority: The European Union Per Regulation 305/2011, Directive 98/34/EC, Directive 2004/18/EC]



BLANK PAGE



English version

**Eurocode 3: Design of steel structures - Part 1-2: General rules -
Structural fire design**

Eurocode 3: Calcul des structures en acier - Partie 1-2:
Règles générales - Calcul du comportement au feu

Eurocode 3: Bemessung und Konstruktion von Stahlbauten
- Teil 1-2: Allgemeine Regeln - Tragwerksbemessung für
den Brandfall

This European Standard was approved by CEN on 23 April 2004.

CEN members are bound to comply with the CEN/CENELEC Internal Regulations which stipulate the conditions for giving this European Standard the status of a national standard without any alteration. Up-to-date lists and bibliographical references concerning such national standards may be obtained on application to the Central Secretariat or to any CEN member.

This European Standard exists in three official versions (English, French, German). A version in any other language made by translation under the responsibility of a CEN member into its own language and notified to the Central Secretariat has the same status as the official versions.

CEN members are the national standards bodies of Austria, Belgium, Cyprus, Czech Republic, Denmark, Estonia, Finland, France, Germany, Greece, Hungary, Iceland, Ireland, Italy, Latvia, Lithuania, Luxembourg, Malta, Netherlands, Norway, Poland, Portugal, Slovakia, Slovenia, Spain, Sweden, Switzerland and United Kingdom.



EUROPEAN COMMITTEE FOR STANDARDIZATION
COMITÉ EUROPÉEN DE NORMALISATION
EUROPÄISCHES KOMITEE FÜR NORMUNG

Management Centre: rue de Stassart, 36 B-1050 Brussels

Contents

Page

Foreword	4
1. General	9
1.1 Scope	9
1.2 Normative references.....	10
1.3 Assumptions	11
1.4 Distinction between principles and application rules.....	11
1.5 Terms and definitions	11
1.6 Symbols.....	12
2 Basis of design	16
2.1 Requirements.....	16
2.1.1 Basic requirements	16
2.1.2 Nominal fire exposure	16
2.1.3 Parametric fire exposure.....	16
2.2 Actions.....	17
2.3 Design values of material properties	17
2.4 Verification methods	17
2.4.1 General	17
2.4.2 Member analysis.....	18
2.4.3 Analysis of part of the structure	19
2.4.4 Global structural analysis	20
3 Material properties.....	20
3.1 General	20
3.2 Mechanical properties of carbon steels	20
3.2.1 Strength and deformation properties	20
3.2.2 Unit mass	20
3.3 Mechanical properties of stainless steels.....	23
3.4 Thermal properties.....	23
3.4.1 Carbon steels	23
3.4.2 Stainless steels	26
3.4.3 Fire protection materials.....	26
4 Structural fire design	27
4.1 General	27
4.2 Simple calculation models.....	27
4.2.1 General	27
4.2.2 Classification of cross-sections	28
4.2.3 Resistance	28
4.2.4 Critical temperature	36
4.2.5 Steel temperature development	37
4.3 Advanced calculation models.....	43
4.3.1 General	43
4.3.2 Thermal response.....	43
4.3.3 Mechanical response.....	43
4.3.4 Validation of advanced calculation models.....	44
Annex A [normative] Strain-hardening of carbon steel at elevated temperatures.....	45
Annex B [normative] Heat transfer to external steelwork	47
Annex C [informative] Stainless steel.....	65
Annex D [informative] Joints	73

Annex E [informative] Class 4 cross-sections76

Foreword

This European Standard EN 1993, Eurocode 3: Design of steel structures, has been prepared by Technical Committee CEN/TC250 « Structural Eurocodes », the Secretariat of which is held by BSI. CEN/TC250 is responsible for all Structural Eurocodes.

This European Standard shall be given the status of a National Standard, either by publication of an identical text or by endorsement, at the latest by October 2005, and conflicting National Standards shall be withdrawn at latest by March 2010.

This Eurocode supersedes ENV 1993-1-2.

According to the CEN-CENELEC Internal Regulations, the National Standard Organizations of the following countries are bound to implement these European Standard: Austria, Belgium, Cyprus, Czech Republic, Denmark, Estonia, Finland, France, Germany, Greece, Hungary, Iceland, Ireland, Italy, Latvia, Lithuania, Luxembourg, Malta, Netherlands, Norway, Poland, Portugal, Slovakia, Slovenia, Spain, Sweden, Switzerland and United Kingdom.

Background to the Eurocode programme

In 1975, the Commission of the European Community decided on an action programme in the field of construction, based on article 95 of the Treaty. The objective of the programme was the elimination of technical obstacles to trade and the harmonization of technical specifications.

Within this action programme, the Commission took the initiative to establish a set of harmonized technical rules for the design of construction works which, in a first stage, would serve as an alternative to the national rules in force in the Member States and, ultimately, would replace them.

For fifteen years, the Commission, with the help of a Steering Committee with Representatives of Member States, conducted the development of the Eurocodes programme, which led to the first generation of European codes in the 1980s.

In 1989, the Commission and the Member States of the EU and EFTA decided, on the basis of an agreement¹ between the Commission and CEN, to transfer the preparation and the publication of the Eurocodes to CEN through a series of Mandates, in order to provide them with a future status of European Standard (EN). This links *de facto* the Eurocodes with the provisions of all the Council's Directives and/or Commission's Decisions dealing with European standards (e.g. the Council Directive 89/106/EEC on construction products - CPD - and Council Directives 93/37/EEC, 92/50/EEC and 89/440/EEC on public works and services and equivalent EFTA Directives initiated in pursuit of setting up the internal market).

The Structural Eurocode programme comprises the following standards generally consisting of a number of Parts:

EN 1990	Eurocode 0:	Basis of Structural Design
EN 1991	Eurocode 1:	Actions on structures
EN 1992	Eurocode 2:	Design of concrete structures
EN 1993	Eurocode 3:	Design of steel structures
EN 1994	Eurocode 4:	Design of composite steel and concrete structures
EN 1995	Eurocode 5:	Design of timber structures
EN 1996	Eurocode 6:	Design of masonry structures
EN 1997	Eurocode 7:	Geotechnical design
EN 1998	Eurocode 8:	Design of structures for earthquake resistance
EN 1999	Eurocode 9:	Design of aluminium structures

¹ Agreement between the Commission of the European Communities and the European Committee for Standardisation (CEN) concerning the work on EUROCODES for the design of building and civil engineering works (BC/CEN/03/89).

Eurocode standards recognize the responsibility of regulatory authorities in each Member State and have safeguarded their right to determine values related to regulatory safety matters at national level where these continue to vary from State to State.

Status and field of application of eurocodes

The Member States of the EU and EFTA recognize that Eurocodes serve as reference documents for the following purposes :

- as a means to prove compliance of building and civil engineering works with the essential requirements of Council Directive 89/106/EEC, particularly Essential Requirement N°1 – Mechanical resistance and stability – and Essential Requirement N°2 – Safety in case of fire;
- as a basis for specifying contracts for construction works and related engineering services;
- as a framework for drawing up harmonized technical specifications for construction products (ENs and ETAs)

The Eurocodes, as far as they concern the construction works themselves, have a direct relationship with the Interpretative Documents² referred to in Article 12 of the CPD, although they are of a different nature from harmonized product standards³. Therefore, technical aspects arising from the Eurocodes work need to be adequately considered by CEN Technical Committees and/or EOTA Working Groups working on product standards with a view to achieving full compatibility of these technical specifications with the Eurocodes.

The Eurocode standards provide common structural design rules for everyday use for the design of whole structures and component products of both a traditional and an innovative nature. Unusual forms of construction or design conditions are not specifically covered and additional expert consideration will be required by the designer in such cases.

National Standards implementing Eurocodes

The National Standards implementing Eurocodes will comprise the full text of the Eurocode (including any annexes), as published by CEN, which may be preceded by a National title page and National foreword, and may be followed by a National annex.

The National annex may only contain information on those parameters which are left open in the Eurocode for national choice, known as Nationally Determined Parameters, to be used for the design of buildings and civil engineering works to be constructed in the country concerned, *i.e.* :

- values and/or classes where alternatives are given in the Eurocode,
- values to be used where a symbol only is given in the Eurocode,
- country specific data (geographical, climatic, etc.), *e.g.* snow map,
- the procedure to be used where alternative procedures are given in the Eurocode.

It may contain

- decisions on the application of informative annexes,
- references to non-contradictory complementary information to assist the user to apply the Eurocode.

² According to Art. 3.3 of the CPD, the essential requirements (ERs) shall be given concrete form in interpretative documents for the creation of the necessary links between the essential requirements and the mandates for harmonized ENs and ETAGs/ETAs.

³ According to Art. 12 of the CPD the interpretative documents shall :

- a) give concrete form to the essential requirements by harmonizing the terminology and the technical bases and indicating classes or levels for each requirement where necessary ;
- b) indicate methods of correlating these classes or levels of requirement with the technical specifications, *e.g.* methods of calculation and of proof, technical rules for project design, etc. ;
- c) serve as a reference for the establishment of harmonized standards and guidelines for European technical approvals.

The Eurocodes, *de facto*, play a similar role in the field of the ER 1 and a part of ER 2.

Links between Eurocodes and harmonized technical specifications (ENs and ETAs) for products

There is a need for consistency between the harmonized technical specifications for construction products and the technical rules for works⁴. Furthermore, all the information accompanying the CE Marking of the construction products which refer to Eurocodes should clearly mention which Nationally Determined Parameters have been taken into account.

Additional information specific to EN 1993-1-2

EN 1993-1-2 describes the principles, requirements and rules for the structural design of steel buildings exposed to fire, including the following aspects.

Safety requirements

EN 1993-1-2 is intended for clients (e.g. for the formulation of their specific requirements), designers, contractors and relevant authorities.

The general objectives of fire protection are to limit risks with respect to the individual and society, neighbouring property, and where required, environment or directly exposed property, in the case of fire.

Construction Products Directive 89/106/EEC gives the following essential requirement for the limitation of fire risks:

"The construction works must be designed and build in such a way, that in the event of an outbreak of fire

- the load bearing resistance of the construction can be assumed for a specified period of time
- the generation and spread of fire and smoke within the works are limited
- the spread of fire to neighbouring construction works is limited
- the occupants can leave the works or can be rescued by other means
- the safety of rescue teams is taken into consideration".

According to the Interpretative Document N° 2 "Safety in case of fire" the essential requirement may be observed by following various possibilities for fire safety strategies prevailing in the Member States like conventional fire scenarios (nominal fires) or "natural" (parametric) fire scenarios, including passive and/or active fire protection measures.

The fire parts of Structural Eurocodes deal with specific aspects of passive fire protection in terms of designing structures and parts thereof for adequate load bearing resistance and for limiting fire spread as relevant.

Required functions and levels of performance can be specified either in terms of nominal (standard) fire resistance rating, generally given in national fire regulations or by referring to fire safety engineering for assessing passive and active measures.

Supplementary requirements concerning, for example

- the possible installation and maintenance of sprinkler systems,
- conditions on occupancy of building or fire compartment,
- the use of approved insulation and coating materials, including their maintenance,

are not given in this document, because they are subject to specification by the competent authority.

Numerical values for partial factors and other reliability elements are given as recommended values that provide an acceptable level of reliability. They have been selected assuming that an appropriate level of workmanship and of quality management applies.

⁴ see Art.3.3 and Art.12 of the CPD, as well as clauses 4.2, 4.3.1, 4.3.2 and 5.2 of ID 1.

Design procedures

A full analytical procedure for structural fire design would take into account the behaviour of the structural system at elevated temperatures, the potential heat exposure and the beneficial effects of active and passive fire protection systems, together with the uncertainties associated with these three features and the importance of the structure (consequences of failure).

At the present time it is possible to undertake a procedure for determining adequate performance which incorporates some, if not all, of these parameters and to demonstrate that the structure, or its components, will give adequate performance in a real building fire. However, where the procedure is based on a nominal (standard) fire the classification system, which calls for specific periods of fire resistance, takes into account (though not explicitly), the features and uncertainties described above.

Application of this Part 1-2 is illustrated in Figure 1. The prescriptive approach and the performance-based approach are identified. The prescriptive approach uses nominal fires to generate thermal actions. The performance-based approach, using fire safety engineering, refers to thermal actions based on physical and chemical parameters.

For design according to this part, EN 1991-1-2 is required for the determination of thermal and mechanical actions to the structure.

Design aids

Where simple calculation models are not available, the Eurocode fire parts give design solutions in terms of tabulated data (based on tests or advanced calculation models), which may be used within the specified limits of validity.

It is expected, that design aids based on the calculation models given in EN 1993-1-2, will be prepared by interested external organizations.

The main text of EN 1993-1-2 together with normative Annexes includes most of the principal concepts and rules necessary for structural fire design of steel structures.

National Annex for EN 1993-1-2

This standard gives alternative procedures, values and recommendations for classes with notes indicating where national choices may have to be made. Therefore the National Standard implementing EN 1993-1-2 should have a National annex containing all Nationally Determined Parameters to be used for the design of steel structures to be constructed in the relevant country.

National choice is allowed in EN 1993-1-2 through paragraphs:

- 2.3 (1)
- 2.3 (2)
- 4.1 (2)
- 4.2.3.6 (1)
- 4.2.4 (2)

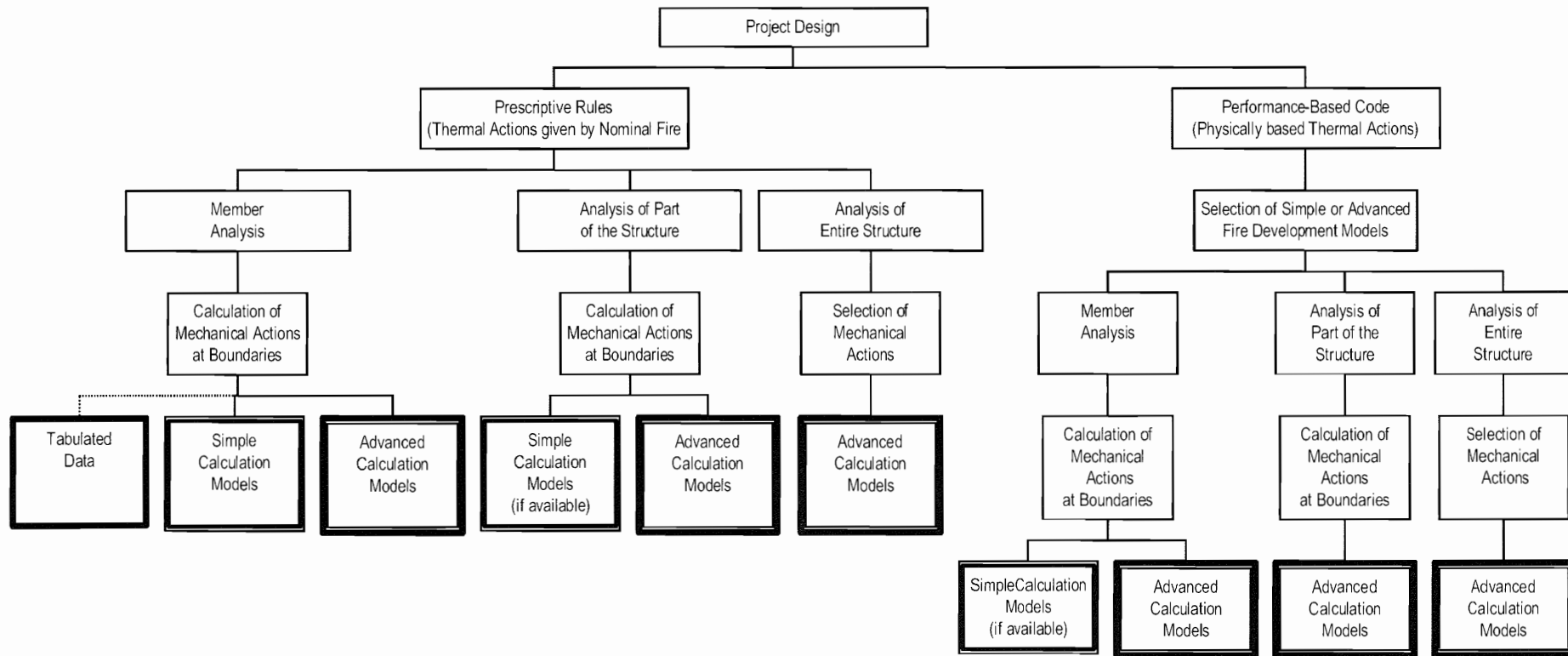

Figure 0.1: Design procedure

1. General

1.1 Scope

1.1.1 Scope of EN 1993

(1) EN 1993 applies to the design of buildings and civil engineering works in steel. It complies with the principles and requirements for the safety and serviceability of structures, the basis of their design and verification that are given in EN 1990 – Basis of structural design.

(2) EN 1993 is only concerned with requirements for resistance, serviceability, durability and fire resistance of steel structures. Other requirements, e.g concerning thermal or sound insulation, are not considered.

(3) EN 1993 is intended to be used in conjunction with:

- EN 1990 “Basis of structural design”
- EN 1991 “Actions on structures”
- hEN’s for construction products relevant for steel structures
- EN 1090 “Execution of steel structures”
- EN 1998 “Design of structures for earthquake resistance”, where steel structures are built in seismic regions

(4) EN 1993 is subdivided in six parts:

- EN 1993-1 Design of Steel Structures : Generic rules.
- EN 1993-2 Design of Steel Structures : Steel bridges.
- EN 1993-3 Design of Steel Structures : Towers, masts and chimneys.
- EN 1993-4 Design of Steel Structures : Silos, tanks and pipelines.
- EN 1993-5 Design of Steel Structures : Piling.
- EN 1993-6 Design of Steel Structures : Crane supporting structures.

1.1.2 Scope of EN 1993-1-2

(1) EN 1993-1-2 deals with the design of steel structures for the accidental situation of fire exposure and is intended to be used in conjunction with EN 1993-1-1 and EN 1991-1-2. EN 1993-1-2 only identifies differences from, or supplements to, normal temperature design.

(2) EN 1993-1-2 deals only with passive methods of fire protection.

(3) EN 1993-1-2 applies to steel structures that are required to fulfil this load bearing function if exposed to fire, in terms of avoiding premature collapse of the structure.

NOTE: This part does not include rules for separating elements.

(4) EN 1993-1-2 gives principles and application rules for designing structures for specified requirements in respect of the load bearing function and the levels of performance.

(5) EN 1993-1-2 applies to structures, or parts of structures, that are within the scope of EN 1993-1 and are designed accordingly.

BS EN 1993-1-2:2005 EN 1993-1-2:2005 (E)

(6) The methods given are applicable to structural steel grades S235, S275, S355, S420 and S460 of EN 10025 and all grades of EN 10210 and EN 10219.

(7) The methods given are also applicable to cold-formed steel members and sheeting within the scope of EN 1993-1-3.

(8) The methods given are applicable to any steel grade for which material properties at elevated temperatures are available, based on harmonized European standards.

(9) The methods given are also applicable stainless steel members and sheeting within the scope of EN 1993-1-4.

NOTE: For the fire resistance of composite steel and concrete structures, see EN 1994-1-2.

1.2 Normative references

(1) This European Standard incorporates by dated or undated reference, provisions from other publications. These normative references are cited at the appropriate places in the text and the publications are listed hereafter. For dated references subsequent amendments to or revisions of any of these publications apply to this European Standard only when incorporated in it by amendment or revision. For undated references the latest edition of the publication referred to applies (including amendments).

EN 10025 Hot rolled products of structural steels;

AC₂ *Text deleted* **AC₂**

EN 10210 Hot finished structural hollow sections of non-alloy and fine grain structural steels:

Part 1: *Technical delivery conditions;*

EN 10219 Cold formed welded structural hollow sections of non-alloy and fine grain structural steels:

Part 1: *Technical delivery conditions;*

EN 1363 Fire resistance: General requirements;

EN 13501 Fire classification of construction products and building elements

Part 2: *Classification using data from fire resistance tests*

ENV 13381 Fire tests on elements of building construction:

Part 1: *Test method for determining the contribution to the fire resistance of structural members: by horizontal protective membranes;*

Part 2: *Test method for determining the contribution to the fire resistance of structural members: by vertical protective membranes;*

Part 4: *Test method for determining the contribution to the fire resistance of structural members: by applied protection to steel structural elements;*

EN 1990 Eurocode: Basis of structural design

EN 1991 Eurocode 1. Actions on structures:

Part 1-2: *Actions on structures exposed to fire;*

EN 1993 Eurocode 3. Design of steel structures:

Part 1-1: *General rules: General rules and rules for buildings;*

Part 1-3: *General rules: Supplementary rules for cold formed steel members and sheeting;*

Part 1-4: *General rules: Supplementary rules for stainless steels*

Part 1-8: *General Rules: Design of joints*

EN 1994 Eurocode 4. Design of composite steel and concrete structures:

Part 1-2: *General rules: Structural fire design;*

ISO 1000 SI units.

1.3 Assumptions

- (1) In addition to the general assumptions of EN 1990 the following assumption applies:
 - Any passive fire protection systems taken into account in the design should be adequately maintained.

1.4 Distinction between principles and application rules

- (1) The rules given in clause 1.4 of EN1990 and EN1991-1-2 apply.

1.5 Terms and definitions

- (1) The rules in EN 1990 clause 1.5 apply.
- (2) The following terms and definitions are used in EN 1993-1-2 with the following meanings:

1.5.1 Special terms relating to design in general

1.5.1.1 Braced frame

A frame may be classified as braced if its sway resistance is supplied by a bracing system with a response to in-plane horizontal loads which is sufficiently stiff for it to be acceptably accurate to assume that all horizontal loads are resisted by the bracing system.

1.5.1.2 Part of structure

Isolated part of an entire structure with appropriate support and boundary conditions.

1.5.2 Terms relating to thermal actions

1.5.2.1 Standard temperature-time curve

A nominal curve, defined in EN 13501-2 for representing a model of a fully developed fire in a compartment.

1.5.3 Terms relating to material and products

1.5.3.1 Carbon steel

In this standard: steel grades according to in EN1993-1-1, except stainless steels

1.5.3.2 Fire protection material

Any material or combination of materials applied to a structural member for the purpose of increasing its fire resistance.

1.5.3.3 Stainless steel

All steels referred to in EN 1993-1-4.

1.5.4 Terms relating to heat transfer analysis

1.5.4.1 Configuration factor

The configuration factor for radiative heat transfer from surface A to surface B is defined as the fraction of diffusely radiated energy leaving surface A that is incident on surface B.

1.5.4.2 Convective heat transfer coefficient

Convective heat flux to the member related to the difference between the bulk temperature of gas bordering the relevant surface of the member and the temperature of that surface.

1.5.4.3 Emissivity

Equal to absorptivity of a surface, i.e. the ratio between the radiative heat absorbed by a given surface, and that of a black body surface.

BS EN 1993-1-2:2005 EN 1993-1-2:2005 (E)

1.5.4.4 Net heat flux

Energy per unit time and surface area definitely absorbed by members.

1.5.4.5 Section factor

For a steel member, the ratio between the exposed surface area and the volume of steel; for an enclosed member, the ratio between the internal surface area of the exposed encasement and the volume of steel.

1.5.4.6 Box value of section factor

Ratio between the exposed surface area of a notional bounding box to the section and the volume of steel.

1.5.5 Terms relating to mechanical behaviour analysis

1.5.5.1 Critical temperature of structural steel element

For a given load level, the temperature at which failure is expected to occur in a structural steel element for a uniform temperature distribution.

1.5.5.2 Effective yield strength

For a given temperature, the stress level at which the stress-strain relationship of steel is truncated to provide a yield plateau.

1.6 Symbols

(1) For the purpose of EN 1993-1-2, the following symbols apply:

Latin upper case letters

A_i	an elemental area of the cross-section with a temperature θ_i ;
A_m	the surface area of a member per unit length;
A_m/V	the section factor for unprotected steel members;
C_i	the protection coefficient of member face i ;
A_p	the appropriate area of fire protection material per unit length of the member $\langle AC_2 \rangle$ [m^2/m] $\langle AC_2 \rangle$;
E_a	the modulus of elasticity of steel for normal temperature design;
$E_{a,\theta}$	the slope of the linear elastic range for steel at elevated temperature θ_a ;
$E_{fi,d}$	the design effect of actions for the fire situation, determined in accordance with EN 1991-1-2, including the effects of thermal expansions and deformations;
$F_{b,Rd}$	the design bearing resistance of bolts;
$F_{b,t,Rd}$	the design bearing resistance of bolts in fire;
$F_{v,Rd}$	the design shear resistance of a bolt per shear plane calculated assuming that the shear plane passes through the threads of the bolt;
$F_{v,t,Rd}$	the fire design resistance of bolts loaded in shear;
$F_{w,Rd}$	the design resistance per unit length of a fillet weld;
$F_{w,t,Rd}$	the design resistance per unit length of a fillet weld in fire;
G_k	the characteristic value of a permanent action;
I_f	the radiative heat flux from an opening;
I_z	the radiative heat flux from a flame;
$I_{z,i}$	the radiative heat flux from a flame to a column face i ;
L	the system length of a column in the relevant storey

$M_{b,fi,t,Rd}$	the design buckling resistance moment at time t
$M_{fi,t,Rd}$	the design moment resistance at time t
$M_{fi,\theta,Rd}$	the design moment resistance of the cross-section for a uniform temperature θ_a which is equal to the uniform temperature θ_a at time t in a cross-section which is not thermally influenced by the supports.;
M_{Rd}	the plastic moment resistance of the gross cross-section $M_{pl,Rd}$ for normal temperature design; the elastic moment resistance of the gross cross-section $M_{el,Rd}$ for normal temperature design;
$N_{b,fi,t,Rd}$	the design buckling resistance at time t of a compression member
N_{Rd}	the design resistance of the cross-section $N_{pl,Rd}$ for normal temperature design, according to EN 1993-1-1.
$N_{fi,\theta,Rd}$	the design resistance of a tension member a uniform temperature θ_a
$N_{fi,t,Rd}$	the design resistance at time t of a tension member with a non-uniform temperature distribution across the cross-section
$Q_{k,1}$	the principal variable load;
$R_{fi,d,t}$	the corresponding design resistance in the fire situation.
$R_{fi,d,0}$	the value of $R_{fi,d,t}$ for time $t = 0$;
T_f	the temperature of a fire [K];
T_o	the flame temperature at the opening [K];
T_x	the flame temperature at the flame tip [813 K];
T_z	the flame temperature [K];
$T_{z,1}$	the flame temperature [K] from annex B of EN 1991-1-2, level with the bottom of a beam;
$T_{z,2}$	the flame temperature [K] from annex B of EN 1991-1-2, level with the top of a beam;
V	the volume of a member per unit length;
$V_{fi,t,Rd}$	the design shear resistance at time t
V_{Rd}	the shear resistance of the gross cross-section for normal temperature design, according to EN 1993-1-1;
X_k	the characteristic value of a strength or deformation property (<i>generally</i> f_k or E_k) for normal temperature design to EN 1993-1-1;

Latin lower case letters

a_z	the absorptivity of flames;
c	the specific heat;
c_a	the specific heat of steel;
c_p	the temperature independent specific heat of the fire protection material;
d_i	the cross-sectional dimension of member face i ;
d_p	the thickness of fire protection material;
d_f	the thickness of the fire protection material. ($d_f = 0$ for unprotected members.)
$f_{p,\theta}$	the proportional limit for steel at elevated temperature θ_a ;

BS EN 1993-1-2:2005
EN 1993-1-2:2005 (E)

- f_y the yield strength at 20°C
- $f_{y,0}$ the effective yield strength of steel at elevated temperature θ_a ;
- $f_{y,i}$ the nominal yield strength f_y for the elemental area A_i taken as positive on the compression side of the plastic neutral axis and negative on the tension side;
- $f_{u,0}$ the ultimate strength at elevated temperature, allowing for strain-hardening.
- $\dot{h}_{\text{net,d}}$ the design value of the net heat flux per unit area;
- h_z the height of the top of the flame above the bottom of the beam;
- i the column face indicator (1), (2), (3) or (4);
- AC2 $k_{b,0}$ AC2 the reduction factor determined for the appropriate bolt temperature;
- $k_{E,0}$ the reduction factor from section 3 for the slope of the linear elastic range at the steel temperature θ_a reached at time t .
- $k_{E,0,\text{com}}$ the reduction factor from section 3 for the slope of the linear elastic range at the maximum steel temperature in the compression flange $\theta_{a,\text{com}}$ reached at time t .
- k_{sh} correction factor for the shadow effect;
- k_{θ} the relative value of a strength or deformation property of steel at elevated temperature θ_a ;
- k_{θ} the reduction factor for a strength or deformation property ($X_{k,\theta} / X_k$), dependent on the material temperature, see section 3;
- AC2 $k_{w,0}$ AC2 the strength reduction factor for welds;
- $k_{y,0}$ the reduction factor from section 3 for the yield strength of steel at the steel temperature θ_a reached at time t .
- $k_{y,0,\text{com}}$ the reduction factor from section 3 for the yield strength of steel at the maximum temperature in the compression flange $\theta_{a,\text{com}}$ reached at time t .
- $k_{y,0,i}$ the reduction factor for the yield strength of steel at temperature θ_i ;
- $k_{y,0,\text{max}}$ the reduction factor for the yield strength of steel at the maximum steel temperature $\theta_{a,\text{max}}$ reached at time t ;
- $k_{y,0,\text{web}}$ the reduction factor for the yield strength of steel at the steel temperature θ_{web} , see section 3.
- k_y the interaction factor;
- k_z the interaction factor;
- k_{LT} the interaction factor;
- m the number of openings on side m ;
- n the number of openings on side n ;
- l the length at 20 °C ; a distance from an opening, measured along the flame axis;
- l_{fi} the buckling length of a column for the fire design situation;
- s the horizontal distance from the centreline of a column to a wall of a fire compartment;
- t the time in fire exposure;
- w_i the width of an opening;
- z_i the distance from the plastic neutral axis to the centroid of the elemental area A_i ;

Greek upper case letters

Δt	the time interval;
Δl	the temperature induced expansion;
$\Delta \theta_{g,t}$	the increase of the ambient gas temperature during the time interval Δt ;
$\phi_{i,i}$	the configuration factor of member face i for an opening;
ϕ_f	the overall configuration factor of the member for radiative heat transfer from an opening;
ϕ_z	the overall configuration factor of a member for radiative heat transfer from a flame;
$\phi_{z,i}$	the configuration factor of member face i for a flame;
$\phi_{z,m}$	the overall configuration factor of the column for heat from flames on side m ;
$\phi_{z,n}$	the overall configuration factor of the column for heat from flames on side n ;

Greek lower case letters

α	the convective heat transfer coefficient;
β_M	the equivalent uniform moment factors;
γ_G	the partial factor for permanent actions;
γ_{M2}	the partial factor at normal temperature;
$\gamma_{M,fi}$	the partial factor for the relevant material property, for the fire situation.
$\gamma_{Q,1}$	the partial factor for variable action 1;
ε_f	the emissivity of a flame; the emissivity of an opening;
ε_z	the emissivity of a flame;
$\varepsilon_{z,m}$	the total emissivity of the flames on side m ;
$\varepsilon_{z,n}$	the total emissivity of the flames on side n ;
ξ	a reduction factor for unfavourable permanent actions G ;
η_{fi}	the reduction factor for design load level in the fire situation;
θ	the temperature;
θ_a	the steel temperature [$^{\circ}\text{C}$].
$\theta_{a,cr}$	critical temperature of steel
$\theta_{g,t}$	the ambient gas temperature at time t ;
θ_{web}	the average temperature in the web of the section;
θ_i	the temperature in the elemental area A_i .
κ	the adaptation factor;
κ_1	an adaptation factor for non-uniform temperature across the cross-section;
κ_2	an adaptation factor for non-uniform temperature along the beam;
λ	the thermal conductivity;

BS EN 1993-1-2:2005
EN 1993-1-2:2005 (E)

λ_i	the flame thickness for an opening i ;
λ_p	the thermal conductivity of the fire protection system;
λ_f	the effective thermal conductivity of the fire protection material.
μ_0	the degree of utilization at time $t = 0$.
σ	the Stefan Boltzmann constant [$5,67 \times 10^{-8} \text{ W/m}^2\text{K}^4$];
ρ_a	the unit mass of steel;
ρ_p	the unit mass of the fire protection material;
χ_{fi}	the reduction factor for flexural buckling in the fire design situation;
$\chi_{L,T,fi}$	the reduction factor for lateral-torsional buckling in the fire design situation;
$\chi_{\min,fi}$	the minimum value of $\chi_{y,fi}$ and $\chi_{z,fi}$;
$\chi_{z,fi}$	the reduction factor for flexural buckling about the z-axis in the fire design situation;
$\chi_{y,fi}$	the reduction factor for flexural buckling about the y-axis in the fire design situation;
ψ_{fi}	the combination factor for frequent values, given either by $\psi_{1,1}$ or $\psi_{2,1}$;

2 Basis of design

2.1 Requirements

2.1.1 Basic requirements

AC1 (1)P Where mechanical resistance in the case of fire is required, steel structures shall be designed and constructed in such a way that they maintain their load bearing function during the relevant fire exposure. **AC1**

(2) Deformation criteria should be applied where the protection aims, or the design criteria for separating elements, require consideration of the deformation of the load bearing structure.

(3) Except from (2) consideration of the deformation of the load bearing structure is not necessary in the following cases, as relevant:

- the efficiency of the means of protection has been evaluated according to section 3.4.3;
- and
- the separating elements have to fulfil requirements according to a nominal fire exposure.

2.1.2 Nominal fire exposure

(1) For the standard fire exposure, members should comply with criteria R as follows:

- load bearing only: mechanical resistance (criterion R).

(2) Criterion "R" is assumed to be satisfied where the load bearing function is maintained during the required time of fire exposure.

(3) With the hydrocarbon fire exposure curve the same criteria should apply, however the reference to this specific curve should be identified by the letters "HC".

2.1.3 Parametric fire exposure

(1) The load-bearing function is ensured if collapse is prevented during the complete duration of the fire including the decay phase or during a required period of time.

2.2 Actions

- (1) The thermal and mechanical actions should be taken from EN 1991-1-2.
- (2) In addition to EN 1991-1-2, the emissivity related to the steel surface should be equal to 0,7 for carbon steel and equal to 0,4 for stainless steels according to annex C.

2.3 Design values of material properties

- (1) Design values of mechanical (strength and deformation) material properties $X_{d,fi}$ are defined as follows:

$$X_{d,fi} = k_{\theta} X_k / \gamma_{M,fi} \quad (2.1)$$

where:

- X_k is the characteristic value of a strength or deformation property (*generally* f_k or E_k) for normal temperature design to EN 1993-1-1;
- k_{θ} is the reduction factor for a strength or deformation property ($X_{k,\theta} / X_k$), dependent on the material temperature, see section 3;
- $\gamma_{M,fi}$ is the partial factor for the relevant material property, for the fire situation.

NOTE: For the mechanical properties of steel, the partial factor for the fire situation is given in the national annex. The use of $\gamma_{M,fi} = 1.0$ is recommended.

- (2) Design values of thermal material properties $X_{d,fi}$ are defined as follows:

- if an increase of the property is favourable for safety:

$$X_{d,fi} = X_{k,\theta} / \gamma_{M,fi} \quad (2.2a)$$

- if an increase of the property is unfavourable for safety:

$$X_{d,fi} = \gamma_{M,fi} X_{k,\theta} \quad (2.2b)$$

where:

- $X_{k,\theta}$ is the value of a material property in fire design, generally dependent on the material temperature, see section 3;
- $\gamma_{M,fi}$ is the partial factor for the relevant material property, for the fire situation.

NOTE: For thermal properties of steel, the partial factor for the fire situation see national annex. The use of $\gamma_{M,fi} = 1.0$ is recommended.

2.4 Verification methods

2.4.1 General

- (1) The model of the structural system adopted for design to this Part 1-2 of EN1993 should reflect the expected performance of the structure in fire.

NOTE: Where rules given in this Part 1-2 of EN1993 are valid only for the standard fire exposure, this is identified in the relevant clauses.

AC1 (2)P It shall be verified that, during the relevant duration of fire exposure t : **AC1**

$$E_{fi,d} \leq R_{fi,d,t} \quad (2.3)$$

where:

BS EN 1993-1-2:2005
EN 1993-1-2:2005 (E)

- $E_{fi,d}$ is the design effect of actions for the fire situation, determined in accordance with EN 1991-1-2, including the effects of thermal expansions and deformations;
 $R_{fi,d}$ is the corresponding design resistance in the fire situation.

(3) The structural analysis for the fire situation should be carried out according to EN 1990 5.1.4 (2).

NOTE 1: For member analysis, see 2.4.2;
 For analysis of parts of the structure, see 2.4.3;
 For global structural analysis, see 2.4.4.

NOTE 2: For verifying standard fire resistance requirements, a member analysis is sufficient.

(4) As an alternative to design by calculation, fire design may be based on the results of fire tests, or on fire tests in combination with calculations.

2.4.2 Member analysis

(1) The effect of actions should be determined for time $t=0$ using combination factors $\psi_{1,1}$ or $\psi_{2,1}$ according to EN 1991-1-2 clause 4.3.1.

(2) As a simplification to (1), the effect of actions $E_{d,fi}$ may be obtained from a structural analysis for normal temperature design as:

$$E_{d,fi} = \eta_{fi} E_d \quad (2.4)$$

where:

E_d is the design value of the corresponding force or moment for normal temperature design, for a fundamental combination of actions (see EN 1990);

η_{fi} is the reduction factor for the design load level for the fire situation.

(3) The reduction factor η_{fi} for load combination (6.10) in EN 1990 should be taken as:

$$\eta_{fi} = \frac{G_k + \psi_{fi} Q_{k,1}}{\gamma_G G_k + \gamma_{Q,1} Q_{k,1}} \quad (2.5)$$

or for load combination (6.10a) and (6.10b) in EN 1990 as the smaller value given by the two following expressions:

$$\eta_{fi} = \frac{G_k + \psi_{fi} Q_{k,1}}{\gamma_G G_k + \gamma_{Q,1} \psi_{0,1} Q_{k,1}} \quad (2.5a)$$

$$\eta_{fi} = \frac{G_k + \psi_{fi} Q_{k,1}}{\xi \gamma_G G_k + \gamma_{Q,1} Q_{k,1}} \quad (2.5b)$$

where:

$Q_{k,1}$ is characteristic value of the leading variable action;

G_k is the characteristic value of a permanent action;

γ_G is the partial factor for permanent actions;

$\gamma_{Q,1}$ is the partial factor for variable action 1;

ψ_{fi} is the combination factor for values, given either by $\psi_{1,1}$ or $\psi_{2,1}$, see EN1991-1-2;

ξ is a reduction factor for unfavourable permanent actions G .

NOTE 1: An example of the variation of the reduction factor η_{fi} versus the load ratio $Q_{k,1}/G_k$ for different values of the combination factor $\psi_{fi} = \psi_{1,1}$ according to expression (2.5), is shown in figure 2.1 with the following assumptions: $\gamma_G = 1,35$ and $\gamma_Q = 1,5$. Partial factors are specified in the relevant National annexes of EN 1990. Equations (2.5a) and (2.5b) give slightly higher values.

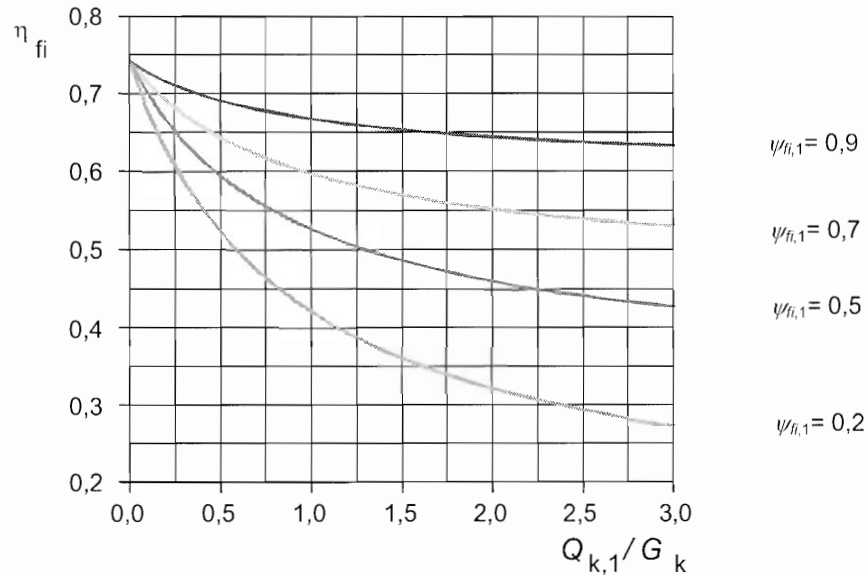

Figure 2.1: Variation of the reduction factor η_{fi} with the load ratio $Q_{k,1}/G_k$

NOTE 2: As a simplification the recommended value of $\eta_{fi} = 0,65$ may be used, except for imposed load according to load category E as given in EN 1991-1-1 (areas susceptible to accumulation of goods, including access areas) where the recommended value is 0,7.

- (4) Only the effects of thermal deformations resulting from thermal gradients across the cross-section need to be considered. The effects of axial or in-plane thermal expansions may be neglected.
- (5) The boundary conditions at supports and ends of member may be assumed to remain unchanged throughout the fire exposure.
- (6) Simplified or advanced calculation methods given in clauses 4.2 and 4.3 respectively are suitable for verifying members under fire conditions.

2.4.3 Analysis of part of the structure

- (1) 2.4.2 (1) applies
- (2) As an alternative to carrying out a structural analysis for the fire situation at time $t = 0$, the reactions at supports and internal forces and moments at boundaries of part of the structure may be obtained from a structural analysis for normal temperature as given in 2.4.2.
- (3) The part of the structure to be analysed should be specified on the basis of the potential thermal expansions and deformations such, that their interaction with other parts of the structure can be approximated by time-independent support and boundary conditions during fire exposure.
- (4) Within the part of the structure to be analyzed, the relevant failure mode in fire exposure, the temperature-dependent material properties and member stiffness, effects of thermal expansions and deformations (indirect fire actions) should be taken into account

(5) The boundary conditions at supports and forces and moments at boundaries of part of the structure may be assumed to remain unchanged throughout the fire exposure.

2.4.4 Global structural analysis

(1) Where a global structural analysis for the fire situation is carried out, the relevant failure mode in fire exposure, the temperature-dependent material properties and member stiffness, effects of thermal deformations (indirect fire actions) should be taken into account.

3 Material properties

3.1 General

(1) Unless given as design values, the values of material properties given in this section should be treated as characteristic values.

(2) The mechanical properties of steel at 20 °C should be taken as those given in EN 1993-1-1 for normal temperature design.

3.2 Mechanical properties of carbon steels

3.2.1 Strength and deformation properties

(1) For heating rates between 2 and 50 K/min, the strength and deformation properties of steel at elevated temperatures should be obtained from the stress-strain relationship given in figure 3.1.

NOTE: For the rules of this standard it is assumed that the heating rates fall within the specified limits.

(2) The relationship given in figure 3.1 should be used to determine the resistances to tension, compression, moment or shear.

(3) Table 3.1 gives the reduction factors for the stress-strain relationship for steel at elevated temperatures given in figure 3.1. These reduction factors are defined as follows:

- effective yield strength, relative to yield strength at 20 °C: $k_{y,\theta} = f_{y,\theta}/f_y$
- proportional limit, relative to yield strength at 20 °C: $k_{p,\theta} = f_{p,\theta}/f_y$
- slope of linear elastic range, relative to slope at 20 °C: $k_{E,\theta} = E_{a,\theta}/E_a$

NOTE: The variation of these reduction factors with temperature is illustrated in figure 3.2.

(4) Alternatively, for temperatures below 400 °C, the stress-strain relationship specified in (1) may be extended by the strain-hardening option given in annex A, provided local or member buckling does not lead to premature collapse.

3.2.2 Unit mass

(1) The unit mass of steel ρ_a may be considered to be independent of the steel temperature. The following value may be taken:

$$\rho_a = 7850 \text{ kg/m}^3$$

Strain range	Stress σ	Tangent modulus
$\varepsilon \leq \varepsilon_{p,\theta}$	$\varepsilon E_{a,\theta}$	$E_{a,\theta}$
$\varepsilon_{p,\theta} < \varepsilon < \varepsilon_{y,\theta}$	$f_{p,\theta} - c + (b/a) [a^2 - (\varepsilon_{y,\theta} - \varepsilon)^2]^{0.5}$	$\frac{b(\varepsilon_{y,\theta} - \varepsilon)}{a [a^2 - (\varepsilon_{y,\theta} - \varepsilon)^2]^{0.5}}$
$\varepsilon_{y,\theta} \leq \varepsilon \leq \varepsilon_{t,\theta}$	$f_{y,\theta}$	0
$\varepsilon_{t,\theta} < \varepsilon < \varepsilon_{u,\theta}$	$f_{y,\theta} [1 - (\varepsilon - \varepsilon_{t,\theta}) / (\varepsilon_{u,\theta} - \varepsilon_{t,\theta})]$	-
$\varepsilon = \varepsilon_{u,\theta}$	0,00	-
Parameters	$\varepsilon_{p,\theta} = f_{p,\theta} / E_{a,\theta}$ $\varepsilon_{y,\theta} = 0,02$	$\varepsilon_{t,\theta} = 0,15$ $\varepsilon_{u,\theta} = 0,20$
Functions	$a^2 = (\varepsilon_{y,\theta} - \varepsilon_{p,\theta})(\varepsilon_{y,\theta} - \varepsilon_{p,\theta} + c / E_{a,\theta})$ $b^2 = c(\varepsilon_{y,\theta} - \varepsilon_{p,\theta})E_{a,\theta} + c^2$ $c = \frac{(f_{y,\theta} - f_{p,\theta})^2}{(\varepsilon_{y,\theta} - \varepsilon_{p,\theta})E_{a,\theta} - 2(f_{y,\theta} - f_{p,\theta})}$	

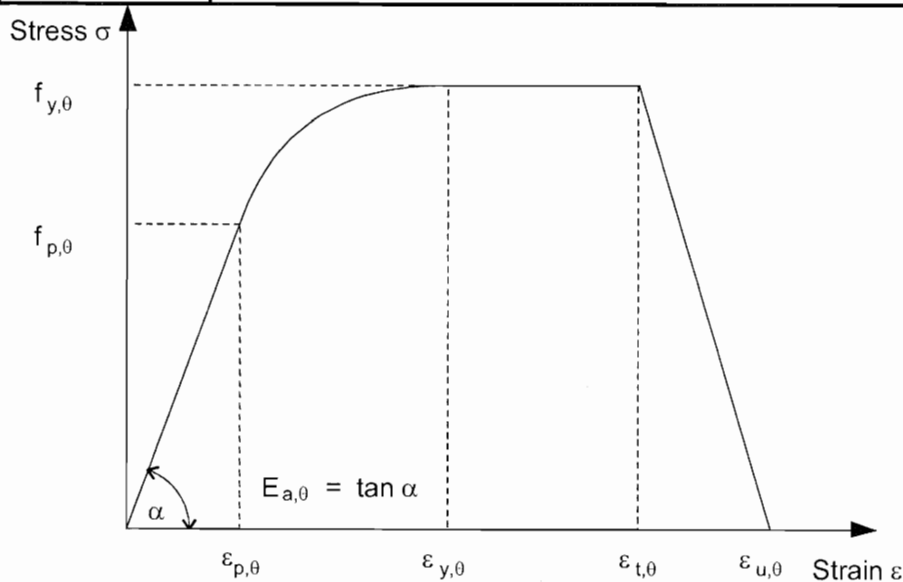

Key:

$f_{y,\theta}$	effective yield strength;
$f_{p,\theta}$	proportional limit;
$E_{a,\theta}$	slope of the linear elastic range;
$\varepsilon_{p,\theta}$	strain at the proportional limit;
$\varepsilon_{y,\theta}$	yield strain;
$\varepsilon_{t,\theta}$	limiting strain for yield strength;
$\varepsilon_{u,\theta}$	ultimate strain.

Figure 3.1: Stress-strain relationship for carbon steel at elevated temperatures.

Table 3.1: Reduction factors for stress-strain relationship of carbon steel at elevated temperatures

Steel Temperature θ_a	Reduction factors at temperature θ_a relative to the value of f_y or E_a at 20°C		
	Reduction factor (relative to f_y) for effective yield strength	Reduction factor (relative to f_y) for proportional limit	Reduction factor (relative to E_a) for the slope of the linear elastic range
	$k_{v,\theta} = f_{v,\theta}/f_y$	$k_{p,\theta} = f_{p,\theta}/f_y$	$k_{E,\theta} = E_{a,\theta}/E_a$
20°C	1,000	1,000	1,000
100°C	1,000	1,000	1,000
200°C	1,000	0,807	0,900
300°C	1,000	0,613	0,800
400°C	1,000	0,420	0,700
500°C	0,780	0,360	0,600
600°C	0,470	0,180	0,310
700°C	0,230	0,075	0,130
800°C	0,110	0,050	0,090
900°C	0,060	0,0375	0,0675
1000°C	0,040	0,0250	0,0450
1100°C	0,020	0,0125	0,0225
1200°C	0,000	0,0000	0,0000

NOTE: For intermediate values of the steel temperature, linear interpolation may be used.

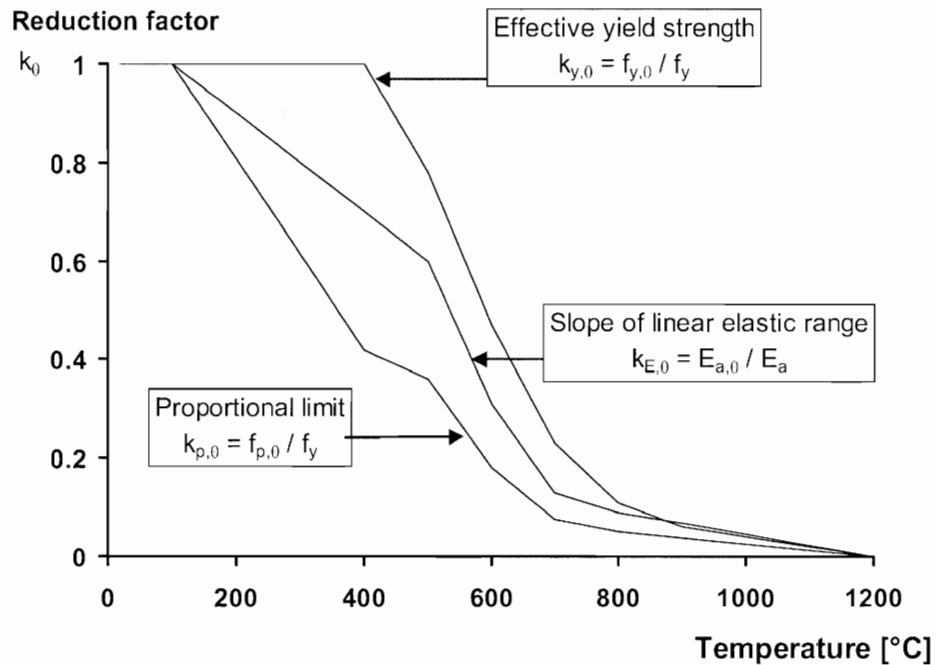

Figure 3.2: Reduction factors for the stress-strain relationship of carbon steel at elevated temperatures

3.3 Mechanical properties of stainless steels

- (1) The mechanical properties of stainless steel may be taken from annex C.

3.4 Thermal properties

3.4.1 Carbon steels

3.4.1.1 Thermal elongation

- (1) The relative thermal elongation of steel Δ/l should be determined from the following:

- for $20^\circ\text{C} \leq \theta_a < 750^\circ\text{C}$:

$$\Delta/l = 1,2 \times 10^{-5} \theta_a + 0,4 \times 10^{-8} \theta_a^2 - 2,416 \times 10^{-4} \quad (3.1a)$$

- for $750^\circ\text{C} \leq \theta_a \leq 860^\circ\text{C}$:

$$\Delta/l = 1,1 \times 10^{-2} \quad (3.1b)$$

- for $860^\circ\text{C} < \theta_a \leq 1200^\circ\text{C}$:

$$\Delta/l = 2 \times 10^{-5} \theta_a - 6,2 \times 10^{-3} \quad (3.1c)$$

where:

- l is the length at 20°C ;
 Δl is the temperature induced elongation;
 θ_a is the steel temperature [$^\circ\text{C}$].

NOTE: The variation of the relative thermal elongation with temperature is illustrated in figure 3.3.

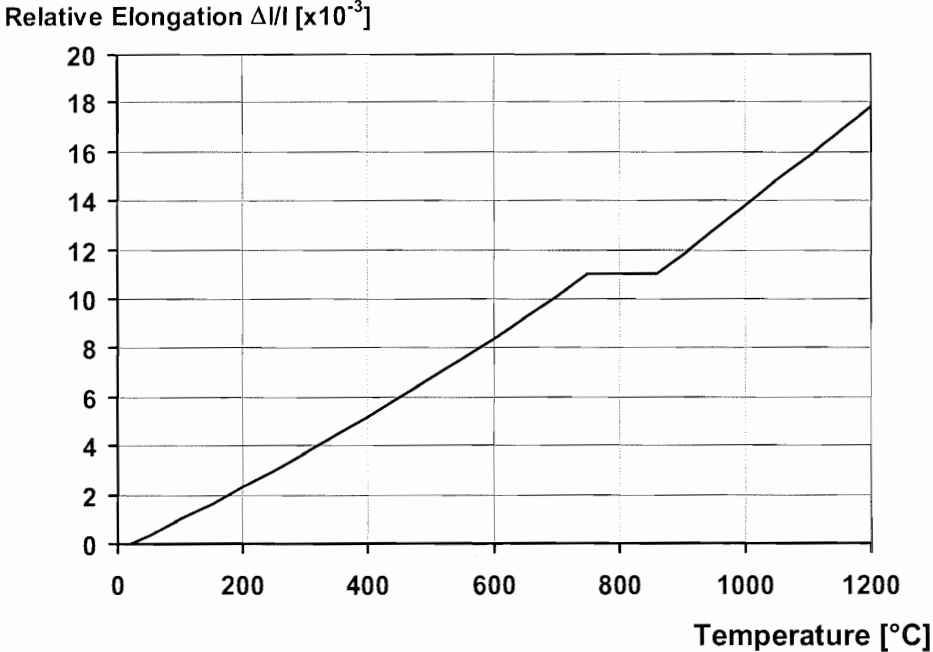

Figure 3.3: Relative thermal elongation of carbon steel as a function of the temperature

3.4.1.2 Specific heat

(1) The specific heat of steel c_a should be determined from the following:

- for $20^\circ\text{C} \leq \theta_a < 600^\circ\text{C}$:

$$c_a = 425 + 7,73 \times 10^{-1} \theta_a - 1,69 \times 10^{-3} \theta_a^2 + 2,22 \times 10^{-6} \theta_a^3 \text{ J/kgK} \quad (3.2a)$$

- for $600^\circ\text{C} \leq \theta_a < 735^\circ\text{C}$:

$$c_a = 666 + \frac{13002}{738 - \theta_a} \text{ J/kgK} \quad (3.2b)$$

- for $735^\circ\text{C} \leq \theta_a < 900^\circ\text{C}$:

$$c_a = 545 + \frac{17820}{\theta_a - 731} \text{ J/kgK} \quad (3.2c)$$

- for $900^\circ\text{C} \leq \theta_a \leq 1200^\circ\text{C}$:

$$c_a = 650 \text{ J/kgK} \quad (3.2d)$$

where:

θ_a is the steel temperature [$^\circ\text{C}$].

NOTE: The variation of the specific heat with temperature is illustrated in figure 3.4.

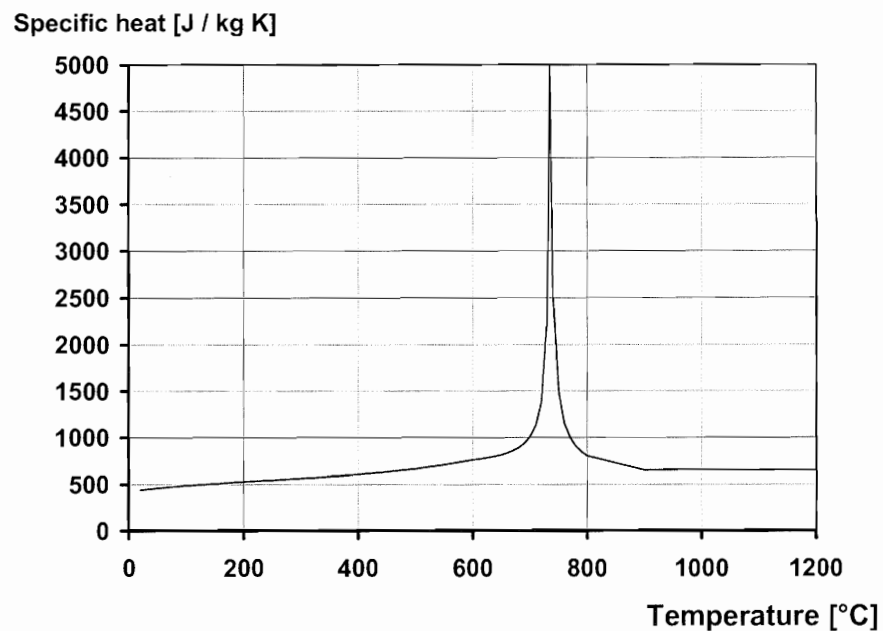

Figure 3.4: Specific heat of carbon steel as a function of the temperature

3.4.1.3 Thermal conductivity

(1) The thermal conductivity of steel λ_a should be determined from the following:

- for $20^\circ\text{C} \leq \theta_a < 800^\circ\text{C}$:

$$\lambda_a = 54 - 3,33 \times 10^{-2} \theta_a \text{ W/mK} \quad (3.3a)$$

- for $800^\circ\text{C} \leq \theta_a \leq 1200^\circ\text{C}$:

$$\lambda_a = 27,3 \text{ W/mK} \quad (3.3b)$$

where:

θ_a is the steel temperature [$^\circ\text{C}$].

NOTE: The variation of the thermal conductivity with temperature is illustrated in figure 3.5.

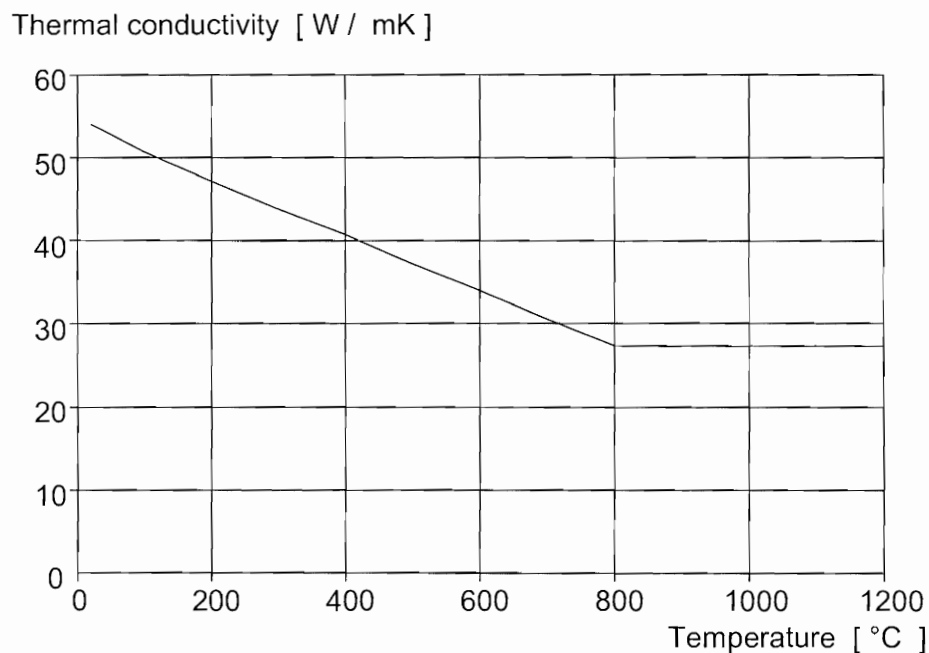

Figure 3.5: Thermal conductivity of carbon steel as a function of the temperature

3.4.2 Stainless steels

(1) The thermal properties of stainless steels may be taken from annex C.

3.4.3 Fire protection materials

(1) The properties and performance of fire protection materials used in design should have been assessed using the test procedures given in ENV 13381-1, ENV 13381-2 or ENV 13381-4 as appropriate.

NOTE: These standards include a requirement that the fire protection materials should remain coherent and cohesive to their supports throughout the relevant fire exposure.

4 Structural fire design

4.1 General

(1) This section gives rules for steelwork that can be either:

- unprotected;
- insulated by fire protection material;
- protected by heat screens.

NOTE: Examples of other protection methods are water filling or partial protection in walls and floors.

(2) To determine the fire resistance the following design methods are permitted:

- simplified calculation models;
- advanced calculation models;
- testing.

NOTE: The decision on use of advanced calculation models in a Country may be found in its National Annex.

(3) Simple calculation models are simplified design methods for individual members, which are based on conservative assumptions.

(4) Advanced calculation models are design methods in which engineering principles are applied in a realistic manner to specific applications.

4.2 Simple calculation models

4.2.1 General

AC1 (1)P The load-bearing function of a steel member shall be assumed to be maintained after a time t in a given fire if: **AC1**

$$E_{fi,d} \leq R_{fi,d,t} \quad (4.1)$$

where:

- $E_{fi,d}$ is the design effect of actions for the fire design situation, according to EN 1991-1-2;
- $R_{fi,d,t}$ is the corresponding design resistance of the steel member, for the fire design situation, at time t .

(2) The design resistance $R_{fi,d,t}$ at time t should be determined, usually in the hypothesis of a uniform temperature in the cross-section, by modifying the design resistance for normal temperature design to EN 1993-1-1, to take account of the mechanical properties of steel at elevated temperatures, see 4.2.3.

NOTE: In 4.2.3 $R_{fi,d,t}$ becomes $M_{fi,t,Rd}$, $N_{fi,t,Rd}$ etc (separately or in combination) and the corresponding values of $M_{fi,Ed}$, $N_{fi,Ed}$ etc represent $E_{fi,d}$.

(3) If a non uniform temperature distribution is used, the design resistance for normal temperature design to EN 1993-1-1 is modified on the base of this temperature distribution.

(4) Alternatively to (1), by using a uniform temperature distribution, the verification may be carried out in the temperature domain, see 4.2.4.

(5) Net-section failure at fastener holes need not be considered, provided that there is a fastener in each hole, because the steel temperature is lower at joints due to the presence of additional material.

(6) The fire resistance of a bolted or a welded joint may be assumed to be sufficient provided that the following conditions are satisfied:

1. The thermal resistance $(d_f/\lambda_f)_c$ of the joint's fire protection should be equal or greater than the minimum value of thermal resistance $(d_f/\lambda_f)_m$ of fire protection applied to any of the jointed members;

Where:

d_f is the thickness of the fire protection material. ($d_f = 0$ for unprotected members.)
 λ_f is the effective thermal conductivity of the fire protection material.

2. The utilization of the joint should be equal or less than the maximum value of utilization of any of the connected members.
3. The resistance of the joint at ambient temperature should satisfy the recommendations given in EN1993-1.8.

(7) As an alternative to the method given in 4.2.1 (6) the fire resistance of a joint may be determined using the method given in Annex D.

NOTE: As a simplification the comparison of the level of utilization within the joints and joined members may be performed for room temperature.

4.2.2 Classification of cross-sections

- (1) For the purpose of these simplified rules the cross-sections may be classified as for normal temperature design with a reduced value for ε as given in (4.2).

$$\varepsilon = 0,85 [235 / f_y]^{0,5} \quad (4.2)$$

where:

f_y is the yield strength at 20°C

NOTE 1: See EN1993-1-1

NOTE 2: The reduction factor 0,85 considers influences due to increasing temperature.

4.2.3 Resistance

4.2.3.1 Tension members

- (1) The design resistance $N_{fi,0,Rd}$ of a tension member with a uniform temperature θ_a should be determined from:

$$N_{fi,0,Rd} = k_{y,0} N_{Rd} [\gamma_{M,0} / \gamma_{M,fi}] \quad (4.3)$$

where:

$k_{y,0}$ is the reduction factor for the yield strength of steel at temperature θ_a , reached at time t see section 3;

N_{Rd} is the design resistance of the cross-section $N_{pl,Rd}$ for normal temperature design, according to EN 1993-1-1.

- (2) The design resistance $N_{fi,t,Rd}$ at time t of a tension member with a non-uniform temperature distribution across the cross-section may be determined from:

$$N_{fi,t,Rd} = \sum_{i=1}^n A_i k_{y,\theta,i} f_y / \gamma_{M,fi} \quad (4.4)$$

where:

- A_i is an elemental area of the cross-section with a temperature θ_i ;
- $k_{y,\theta,i}$ is the reduction factor for the yield strength of steel at temperature θ_i , see section 3;
- θ_i is the temperature in the elemental area A_i .

(3) The design resistance $N_{fi,t,Rd}$ at time t of a tension member with a non-uniform temperature distribution may conservatively be taken as equal to the design resistance $N_{fi,\theta,Rd}$ of a tension member with a uniform steel temperature θ_a equal to the maximum steel temperature $\theta_{a,max}$ reached at time t .

4.2.3.2 Compression members with Class 1, Class 2 or Class 3 cross-sections

(1) The design buckling resistance $N_{b,fi,t,Rd}$ at time t of a compression member with a Class 1, Class 2 or Class 3 cross-section with a uniform temperature θ_a should be determined from:

$$N_{b,fi,t,Rd} = \chi_{fi} A k_{y,\theta} f_y / \gamma_{M,fi} \quad (4.5)$$

where:

- χ_{fi} is the reduction factor for flexural buckling in the fire design situation;
- $k_{y,\theta}$ is the reduction factor from section 3 for the yield strength of steel at the steel temperature θ_a reached at time t .

(2) The value of χ_{fi} should be taken as the lesser of the values of $\chi_{y,fi}$ and $\chi_{z,fi}$ determined according to:

$$\chi_{fi} = \frac{1}{\varphi_{\theta} + \sqrt{\varphi_{\theta}^2 - \bar{\lambda}_{\theta}^2}} \quad (4.6)$$

with

$$\varphi_{\theta} = \frac{1}{2} [1 + \alpha \bar{\lambda}_{\theta} + \bar{\lambda}_{\theta}^2]$$

and

$$\alpha = 0,65 \sqrt{235 / f_y}$$

The non-dimensional slenderness $\bar{\lambda}_{\theta}$ for the temperature θ_a , is given by:

$$\bar{\lambda}_{\theta} = \bar{\lambda} [k_{y,\theta} / k_{E,\theta}]^{0,5} \quad (4.7)$$

where:

- $k_{y,\theta}$ is the reduction factor from section 3 for the yield strength of steel at the steel temperature θ_a reached at time t ;
- $k_{E,\theta}$ is the reduction factor from section 3 for the slope of the linear elastic range at the steel temperature θ_a reached at time t .

(3) The buckling length l_{fi} of a column for the fire design situation should generally be determined as for normal temperature design. However, in a braced frame the buckling length l_{fi} of a column length may be determined by considering it as fixed in direction at continuous or semi-continuous joints to the column lengths in the fire compartments above and below, provided that the fire resistance of the building components that separate these fire compartments is not less than the fire resistance of the column.

(5) In the case of a braced frame in which each storey comprises a separate fire compartment with sufficient fire resistance, in an intermediate storey the buckling length l_{fi} of a continuous column may be taken as $l_{fi} = 0,5L$ and in the top storey the buckling length may be taken as $l_{fi} = 0,7L$, where L is the system length in the relevant storey, see figure 4.1.

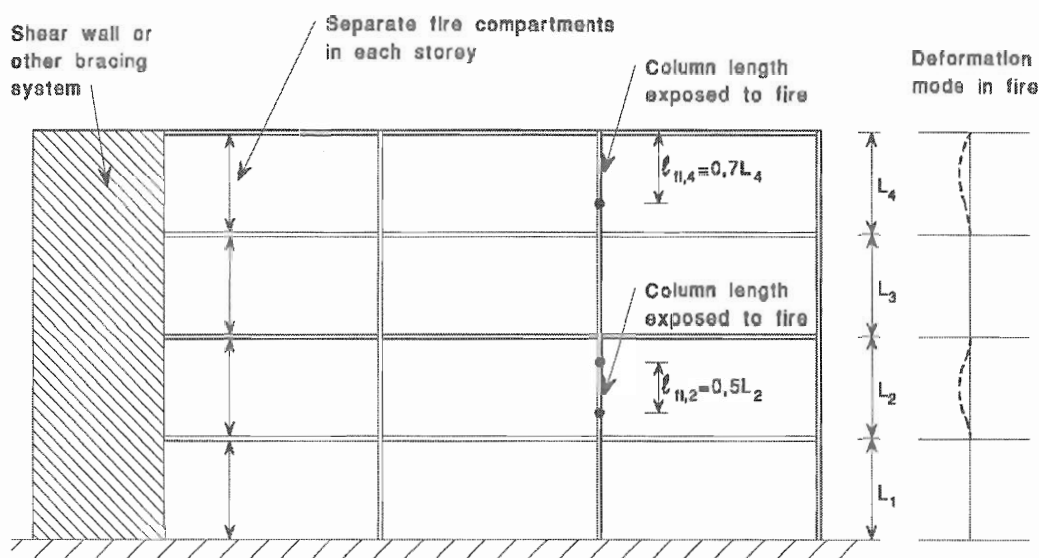

Figure 4.1: Buckling lengths l_{fi} of columns in braced frames

(6) When designing using nominal fire exposure the design resistance $N_{b,fi,t,Rd}$ at time t of a compression member with a non-uniform temperature distribution may be taken as equal to the design resistance $N_{b,fi,\theta,Rd}$ of a compression member with a uniform steel temperature θ_a equal to the maximum steel temperature $\theta_{a,max}$ reached at time t .

4.2.3.3 Beams with Class 1 or Class 2 cross-sections

(1) The design moment resistance $M_{fi,\theta,Rd}$ of a Class 1 or Class 2 cross-section with a uniform temperature θ_a should be determined from:

$$M_{fi,\theta,Rd} = k_{y,\theta} [\gamma_{M,0} / \gamma_{M,fi}] M_{Rd} \quad (4.8)$$

where:

- M_{Rd} is the plastic moment resistance of the gross cross-section $M_{pl,Rd}$ for normal temperature design, according to EN 1993-1-1 or the reduced moment resistance for normal temperature design, allowing for the effects of shear if necessary, according to EN 1993-1-1;
- $k_{y,\theta}$ is the reduction factor for the yield strength of steel at temperature θ_a , see section 3

(2) The design moment resistance $M_{fi,t,Rd}$ at time t of a Class 1 or Class 2 cross-section with a non-uniform temperature distribution across the cross-section may be determined from:

$$M_{fi,t,Rd} = \sum_{i=1}^n A_i z_i k_{y,\theta,i} f_{y,i} / \gamma_{M,fi} \quad (4.9)$$

where:

- z_i is the distance from the plastic neutral axis to the centroid of the elemental area A_i ;
 $f_{y,i}$ is the nominal yield strength f_y for the elemental area A_i taken as positive on the compression side of the plastic neutral axis and negative on the tension side;
 A_i and $k_{y,\theta,i}$ are as defined in 4.2.3.1 (2).

(3) Alternatively, the design moment resistance $M_{fi,t,Rd}$ at time t of a Class 1 or Class 2 cross-section in a member with a non-uniform temperature distribution, may be determined from:

$$M_{fi,t,Rd} = M_{fi,\theta,Rd} / \overline{AC2} (\kappa_1 \kappa_2) \overline{AC2} \quad (4.10)$$

$$\overline{AC2} M_{fi,\theta,Rd} \leq M_{Rd} \overline{AC2}$$

where:

- $M_{fi,\theta,Rd}$ is the design moment resistance of the cross-section for a uniform temperature θ_a which is equal to the uniform temperature θ_a at time t in a cross-section which is not thermally influenced by the support;
 κ_1 is an adaptation factor for non-uniform temperature across the cross-section, see (7);
 κ_2 is an adaptation factor for non-uniform temperature along the beam, see (8).

(4) The design lateral torsional buckling resistance moment $M_{b,fi,t,Rd}$ at time t of a laterally unrestrained member with a Class 1 or Class 2 cross-section should be determined from:

$$M_{b,fi,t,Rd} = \chi_{LT,fi} W_{pl,y} k_{y,\theta,com} f_y / \gamma_{M,fi} \quad (4.11)$$

where:

- $\chi_{LT,fi}$ is the reduction factor for lateral-torsional buckling in the fire design situation;
 $k_{y,\theta,com}$ is the reduction factor from section 3 for the yield strength of steel at the maximum temperature in the compression flange $\theta_{a,com}$ reached at time t .

NOTE : Conservatively $\theta_{a,com}$ can be assumed to be equal to the uniform temperature θ_a .

(5) The value of $\chi_{LT,fi}$ should be determined according to the following equations:

$$\chi_{LT,fi} = \frac{1}{\phi_{LT,\theta,com} + \sqrt{[\phi_{LT,\theta,com}]^2 - [\bar{\lambda}_{LT,\theta,com}]^2}} \quad (4.12)$$

with

$$\phi_{LT,\theta,com} = \frac{1}{2} [1 + \alpha \bar{\lambda}_{LT,\theta,com} + (\bar{\lambda}_{LT,\theta,com})^2] \quad (4.13)$$

and

$$\alpha = 0.65 \sqrt{235 / f_y} \quad (4.14)$$

$$\bar{\lambda}_{LT,\theta,com} = \bar{\lambda}_{LT} [k_{y,\theta,com} / k_{E,\theta,com}]^{0.5} \quad (4.15)$$

where:

- $k_{E,\theta,com}$ is the reduction factor from section 3 for the slope of the linear elastic range at the maximum steel temperature in the compression flange $\theta_{a,com}$ reached at time t .

(6) The design shear resistance $V_{fi,t,Rd}$ at time t of a Class 1 or Class 2 cross-section should be determined from:

$$V_{fi,t,Rd} = k_{y,\theta,web} V_{Rd} [\gamma_{M,0} / \gamma_{M,fi}] \quad (4.16)$$

where:

- V_{Rd} is the shear resistance of the gross cross-section for normal temperature design, according to EN 1993-1-1;
- θ_{web} is the average temperature in the web of the section;
- $k_{y,\theta,web}$ is the reduction factor for the yield strength of steel at the steel temperature θ_{web} , see section 3.

(7) The value of the adaptation factor κ_1 for non-uniform temperature distribution across a cross-section should be taken as follows:

- for a beam exposed on all four sides: $\kappa_1 = 1,0$
- for an unprotected beam exposed on three sides, with a composite or concrete slab on side four: $\kappa_1 = 0,70$
- for a protected beam exposed on three sides, with a composite or concrete slab on side four: $\kappa_1 = 0,85$

(8) For a non-uniform temperature distribution along a beam the adaptation factor κ_2 should be taken as follows:

- at the supports of a statically indeterminate beam: $\kappa_2 = 0,85$
- in all other cases: $\kappa_2 = 1,0$.

4.2.3.4 Beams with Class 3 cross-sections

(1) The design moment resistance $M_{fi,t,Rd}$ at time t of a Class 3 cross-section with a uniform temperature should be determined from:

$$M_{fi,t,Rd} = k_{y,\theta} M_{Rd} [\gamma_{M,0} / \gamma_{M,fi}] \quad (4.17)$$

where:

- M_{Rd} is the elastic moment resistance of the gross cross-section $M_{el,Rd}$ for normal temperature design, according to EN 1993-1-1 or the reduced moment resistance allowing for the effects of shear if necessary according to EN 1993-1-1;
- $k_{y,\theta}$ is the reduction factor for the yield strength of steel at the steel temperature θ_a , see section 3.

(2) The design moment resistance $M_{fi,t,Rd}$ at time t of a Class 3 cross-section with a non-uniform temperature distribution may be determined from:

$$M_{fi,t,Rd} = k_{y,\theta,max} M_{Rd} [\gamma_{M,0} / \gamma_{M,fi}] / \langle AC2 \rangle (\kappa_1 \kappa_2) \langle AC2 \rangle \quad (4.18)$$

$$\langle AC2 \rangle M_{fi,\theta,Rd} \leq M_{Rd} \langle AC2 \rangle$$

where:

- M_{Rd} is the elastic moment resistance of the gross cross-section $M_{el,Rd}$ for normal temperature design or the reduced moment resistance allowing for the effects of shear if necessary according to EN 1993-1-1;
- $k_{y,\theta,max}$ is the reduction factor for the yield strength of steel at the maximum steel temperature $\theta_{a,max}$ reached at time t , ~~AC2~~ text deleted ~~AC2~~;
- κ_1 is an adaptation factor for non-uniform temperature in a cross-section, see 4.2.3.3 (7);

κ_2 is an adaptation factor for non-uniform temperature along the beam, see 4.2.3.3 (8).

(3) The design buckling resistance moment $M_{b,fi,t,Rd}$ at time t of a laterally unrestrained beam with a Class 3 cross-section should be determined from:

$$M_{b,fi,t,Rd} = \chi_{LT,fi} W_{el,y} k_{y,\theta,com} f_y / \gamma_{M,fi} \quad (4.19)$$

where:

$\chi_{LT,fi}$ is as given in 4.2.3.3 (5).

NOTE: Conservatively $\theta_{a,com}$ can be assumed to be equal to the maximum temperature $\theta_{a,max}$.

(4) The design shear resistance $V_{fi,t,Rd}$ at time t of a Class 3 cross-section should be determined from:

$$V_{fi,t,Rd} = k_{y,\theta,web} V_{Rd} [\gamma_{M,0} / \gamma_{M,fi}] \quad (4.20)$$

where:

V_{Rd} is the shear resistance of the gross cross-section for normal temperature design, according to EN 1993-1-1.

4.2.3.5 Members with Class 1, 2 or 3 cross-sections, subject to combined bending and axial compression

(1) The design buckling resistance $R_{fi,t,d}$ at time t of a member subject to combined bending and axial compression should be verified by satisfying expressions (4.21a) and (4.21b) for a member with a Class 1 or Class 2 cross-section, or expressions (4.21c) and (4.21d) for a member with a Class 3 cross-section.

$$\frac{N_{fi,Ed}}{\chi_{min,fi} A k_{y,\theta} \frac{f_y}{\gamma_{M,fi}}} + \frac{k_y M_{y,fi,Ed}}{W_{pl,y} k_{y,\theta} \frac{f_y}{\gamma_{M,fi}}} + \frac{k_z M_{z,fi,Ed}}{W_{pl,z} k_{y,\theta} \frac{f_y}{\gamma_{M,fi}}} \leq 1 \quad (4.21a)$$

$$\frac{N_{fi,Ed}}{\chi_{z,fi} A k_{y,\theta} \frac{f_y}{\gamma_{M,fi}}} + \frac{k_{LT} M_{y,fi,Ed}}{\chi_{LT,fi} W_{pl,y} k_{y,\theta} \frac{f_y}{\gamma_{M,fi}}} + \frac{k_z M_{z,fi,Ed}}{W_{pl,z} k_{y,\theta} \frac{f_y}{\gamma_{M,fi}}} \leq 1 \quad (4.21b)$$

$$\frac{N_{fi,Ed}}{\chi_{min,fi} A k_{y,\theta} \frac{f_y}{\gamma_{M,fi}}} + \frac{k_y M_{y,fi,Ed}}{W_{el,y} k_{y,\theta} \frac{f_y}{\gamma_{M,fi}}} + \frac{k_z M_{z,fi,Ed}}{W_{el,z} k_{y,\theta} \frac{f_y}{\gamma_{M,fi}}} \leq 1 \quad (4.21c)$$

$$\frac{N_{fi,Ed}}{\chi_{z,fi} A k_{y,\theta} \frac{f_y}{\gamma_{M,fi}}} + \frac{k_{LT} M_{y,fi,Ed}}{\chi_{LT,fi} W_{el,y} k_{y,\theta} \frac{f_y}{\gamma_{M,fi}}} + \frac{k_z M_{z,fi,Ed}}{W_{el,z} k_{y,\theta} \frac{f_y}{\gamma_{M,fi}}} \leq 1 \quad (4.21d)$$

where:

$\chi_{min,fi}$ is as defined in 4.2.3.2;

$\chi_{z,fi}$ is as defined in 4.2.3.2;

$\chi_{LT,fi}$ is as defined in 4.2.3.3 (5);

$$k_{LT} = 1 - \frac{\mu_{LT} N_{fi,Ed}}{\chi_{z,fi} A k_{y,\theta} \frac{f_y}{\gamma_{M,fi}}} \leq 1$$

with: $\mu_{LT} = 0,15 \bar{\lambda}_{z,\theta} \beta_{M,LT} - 0,15 \leq 0,9$

$$k_y = 1 - \frac{\mu_y N_{fi,Ed}}{\chi_{y,fi} A k_{y,\theta} \frac{f_y}{\gamma_{M,fi}}} \leq 3$$

with: AC2 For the strong axis:

$$\mu_y = (2\beta_{M,y} - 5)\bar{\lambda}_{y,\theta} + 0,44\beta_{M,y} + 0,29 \leq 0,8 \text{ with } \bar{\lambda}_{y,20^\circ C} \leq 1,1. \text{ AC2}$$

$$k_z = 1 - \frac{\mu_z N_{fi,Ed}}{\chi_{z,fi} A k_{y,\theta} \frac{f_y}{\gamma_{M,fi}}} \leq 3$$

with: AC2 For the weak axis:

$$\mu_z = (1,2\beta_{M,z} - 3)\bar{\lambda}_{z,\theta} + 0,71\beta_{M,z} - 0,29 \leq 0,8 \text{ AC2}$$

NOTE: For the equivalent uniform moment factors β_M see figure 4.2.

Moment diagram	Equivalent uniform moment factor β_M
<p>End moments</p>  <p>M_1 ψM_1</p> <p>$-1 \leq \psi \leq 1$</p>	$\beta_{M,\psi} = 1,8 - 0,7 \psi$
<p>Moments due to in-plane lateral loads</p> 	$\beta_{M,Q} = 1,3$ $\beta_{M,Q} = 1,4$
<p>Moments due to in-plane lateral loads plus end moments</p> 	$\beta_M = \beta_{M,\psi} + \frac{M_Q}{\Delta M} (\beta_{M,Q} - \beta_{M,\psi})$ $M_Q = \max M \text{ due to lateral load only}$ $\Delta M \begin{cases} \max M & \text{for moment diagram without change of sign} \\ \max M + \min M & \text{for moment diagram with change of sign} \end{cases}$

Figure 4.2: Equivalent uniform moment factors.

4.2.3.6 Members with Class 4 cross-sections

(1) For members with class 4 cross-sections other than tension members it may be assumed that 4.2.1(1) is satisfied if at time t the steel temperature θ_a at all cross-sections is not more than θ_{crit} .

NOTE 1 : For further information see annex E.

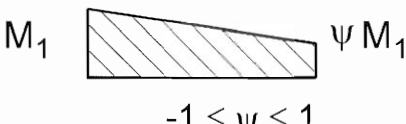
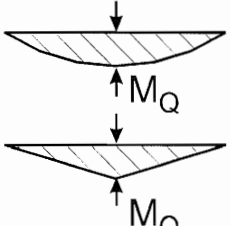
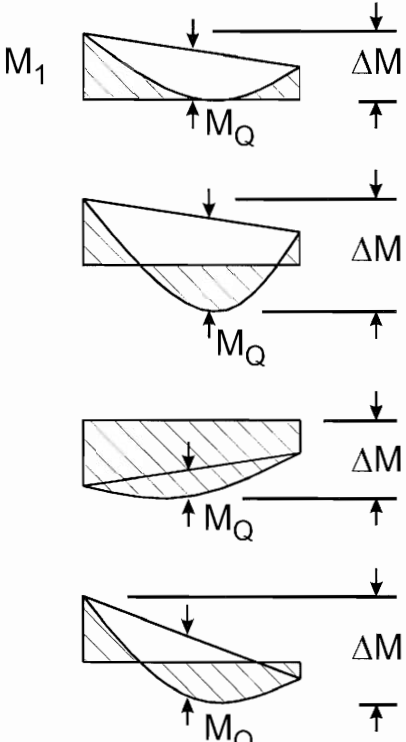
NOTE 2 : The limit θ_{crit} may be chosen in the National Annex. The value $\theta_{crit} = 350^\circ\text{C}$ is recommended.

4.2.4 Critical temperature

(1) As an alternative to 4.2.3, verification may be carried out in the temperature domain.

(2) Except when considering deformation criteria or $\overline{\text{AC2}}$ when instability phenomena have $\overline{\text{AC2}}$ to be taken into account, the critical temperature $\theta_{a,cr}$ of carbon steel according to 1.1.2 (6) at time t for a uniform temperature distribution in a member may be determined for any degree of utilization μ_0 at time $t = 0$ using:

$$\theta_{a,cr} = 39,19 \ln \left[\frac{I}{0,9674 \mu_0^{3,833}} - I \right] + 482 \quad (4.22)$$

where μ_0 must not be taken less than 0,013.

NOTE : Examples for values of $\theta_{a,cr}$ for values of μ_0 from 0,22 to 0,80 are given in table 4.1.

(3) For members with Class 1, Class 2 or Class 3 cross-sections and for all tension members, the degree of utilization μ_0 at time $t = 0$ may be obtained from:

$$\mu_0 = E_{\bar{n},d} / R_{\bar{n},d,0} \quad (4.23)$$

where:

$R_{\bar{n},d,0}$ is the value of $R_{\bar{n},d,t}$ for time $t = 0$, from 4.2.3;

$E_{\bar{n},d}$ and $R_{\bar{n},d,t}$ are as defined in 4.2.1(1).

(4) Alternatively for tension members, and for beams where lateral-torsional buckling is not a potential failure mode, μ_0 may conservatively be obtained from:

$$\mu_0 = \eta_{\bar{n}} [\gamma_{M,\bar{n}} / \gamma_{M0}] \quad (4.24)$$

where:

$\eta_{\bar{n}}$ is the reduction factor defined in $\overline{\text{AC2}}$ 2.4.2 (3) $\overline{\text{AC2}}$.

Table 4.1: Critical temperature $\theta_{a,cr}$ for values of the utilization factor μ_0

μ_0	$\theta_{a,cr}$	μ_0	$\theta_{a,cr}$	μ_0	$\theta_{a,cr}$
0,22	711	0,42	612	0,62	549
0,24	698	0,44	605	0,64	543
0,26	685	0,46	598	0,66	537
0,28	674	0,48	591	0,68	531
0,30	664	0,50	585	0,70	526
0,32	654	0,52	578	0,72	520
0,34	645	0,54	572	0,74	514
0,36	636	0,56	566	0,76	508
0,38	628	0,58	560	0,78	502
0,40	620	0,60	554	0,80	496

NOTE: The national annex may give default values for critical temperatures.

4.2.5 Steel temperature development

4.2.5.1 Unprotected internal steelwork

(1) For an equivalent uniform temperature distribution in the cross-section, the increase of temperature $\Delta\theta_{a,t}$ in an unprotected steel member during a time interval Δt should be determined from:

$$\boxed{\text{AC2}} \Delta\theta_{a,t} = k_{sh} \frac{A_m/V}{c_a \rho_a} \dot{h}_{net,d} \Delta t \quad \boxed{\text{AC2}} \quad (4.25)$$

where:

k_{sh}	is	correction factor for the shadow effect, see (2)
A_m/V	is	the section factor for unprotected steel members [1/m];
A_m	is	the surface area of the member per unit length [m ² /m];
V	is	the volume of the member per unit length [m ³ /m];
c_a	is	the specific heat of steel, from section 3 [J/kgK];
$\boxed{\text{AC2}} \dot{h}_{net,d} \boxed{\text{AC2}}$	is	the design value of the net heat flux per unit area [W/m ²];
Δt	is	the time interval [seconds];
ρ_a	is	the unit mass of steel, from section 3 [kg/m ³].

(2) For I-sections under nominal fire actions, the correction factor for the shadow effect may be determined from:

$$k_{sh} = 0.9 [A_m/V]_b / [A_m/V] \quad (4.26a)$$

where:

$[A_m/V]_b$ is box value of the section factor

In all other cases, the value of k_{sh} should be taken as:

$$k_{sh} = [A_m/V]_b / [A_m/V] \quad (4.26b)$$

BS EN 1993-1-2:2005
EN 1993-1-2:2005 (E)

NOTE (1): For cross sections with a convex shape (e.g. rectangular or circular hollow sections) fully embedded in fire, the shadow effect does not play a role and consequently the correction factor k_{sh} equals unity.

NOTE (2): Ignoring the shadow effect (i.e.: $k_{sh} = 1$), leads to conservative solutions.

(3) The value of $\dot{h}_{net,d}$ should be obtained from EN 1991-1-2 using $\varepsilon_f = 1,0$ and ε_m according to 2.2(2), where ε_f , ε_m are as defined in EN 1991-1-2.

(4) The value of Δt should not be taken as more than 5 seconds.

(5) In expression (4.26) the value of the section factor A_m/V should not be taken as less than 10m^{-1} .

NOTE: Some expressions for calculating design values of the section factor A_m/V for unprotected steel members are given in table 4.2.

Table 4.2: Section factor A_m/V for unprotected steel members.

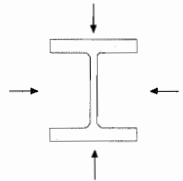
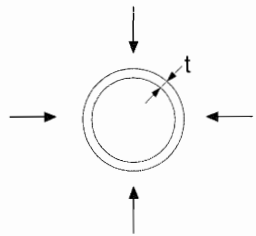
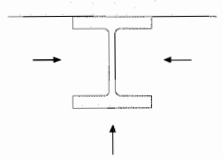
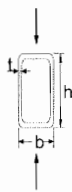
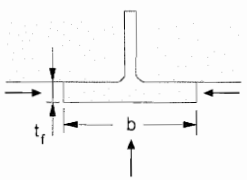
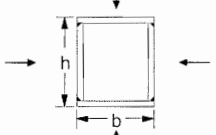
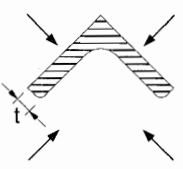
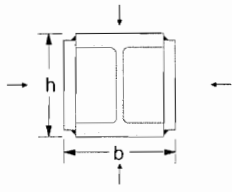
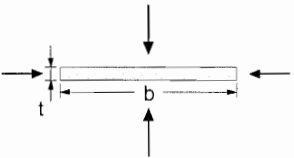
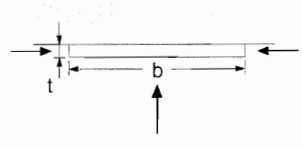
<p>Open section exposed to fire on all sides:</p> $\frac{A_m}{V} = \frac{\text{perimeter}}{\text{cross-section area}}$ 	<p>Tube exposed to fire on all sides: $A_m/V = 1/t$</p> 
<p>Open section exposed to fire on three sides:</p> $\frac{A_m}{V} = \frac{\text{surface exposed to fire}}{\text{cross-section area}}$ 	<p>Hollow section (or welded box section of uniform thickness) exposed to fire on all sides:</p> <p>If $t \ll b$: $A_m/V \approx 1/t$</p> 
<p>I-section flange exposed to fire on three sides:</p> $A_m/V = (b + 2t_f)/(bt_f)$ <p>If $t \ll b$: $A_m/V \approx 1/t_f$</p> 	<p>Welded box section exposed to fire on all sides:</p> $\frac{A_m}{V} = \frac{2(b + h)}{\text{cross-section area}}$ <p>If $t \ll b$: $A_m/V \approx 1/t$</p> 
<p>Angle exposed to fire on all sides:</p> $A_m/V = 2/t$ 	<p>I-section with box reinforcement, exposed to fire on all sides:</p> $\frac{A_m}{V} = \frac{2(b + h)}{\text{cross-section area}}$ 
<p>Flat bar exposed to fire on all sides:</p> $A_m/V = 2(b + t)/(bt)$ <p>If $t \ll b$: $A_m/V \approx 2/t$</p> 	<p>Flat bar exposed to fire on three sides:</p> $A_m/V = (b + 2t)/(bt)$ <p>If $t \ll b$: $A_m/V \approx 1/t$</p> 

4.2.5.2 Internal steelwork insulated by fire protection material

(1) For a uniform temperature distribution in a cross-section, the temperature increase $\Delta\theta_{a,t}$ of an insulated steel member during a time interval Δt should be obtained from:

$$\Delta\theta_{a,t} = \frac{\lambda_p A_p / V (\theta_{g,t} - \theta_{a,t})}{d_p c_a \rho_a (1 + \phi/3)} \Delta t - (e^{\phi/10} - 1) \Delta\theta_{g,t} \quad (\text{but } \Delta\theta_{a,t} \geq 0 \text{ if } \Delta\theta_{g,t} > 0) \quad (4.27)$$

with:

$$\phi = \frac{c_p \rho_p}{c_a \rho_a} d_p A_p / V$$

where:

- A_p/V is the section factor for steel members insulated by fire protection material;
- A_p is the appropriate area of fire protection material per unit length of the member [m^2/m];
- V is the volume of the member per unit length [m^3/m];
- c_a is the temperature dependant specific heat of steel, from section 3 [J/kgK];
- c_p is the temperature independent specific heat of the fire protection material [J/kgK];
- d_p is the thickness of the fire protection material [m];
- Δt is the time interval [seconds];
- $\theta_{a,t}$ is the steel temperature at time t [$^{\circ}\text{C}$];
- $\theta_{g,t}$ is the ambient gas temperature at time t [$^{\circ}\text{C}$];
- $\Delta\theta_{g,t}$ is the increase of the ambient gas temperature during the time interval Δt [K];
- λ_p is the thermal conductivity of the fire protection system [W/mK];
- ρ_a is the unit mass of steel, from section 3 [kg/m^3];
- ρ_p is the unit mass of the fire protection material [kg/m^3].

(2) The values of c_p , λ_p and ρ_p should be determined as specified in section 3.

(3) The value of Δt should not be taken as more than 30 seconds.

(4) The area A_p of the fire protection material should generally be taken as the area of its inner surface, but for hollow encasement with a clearance around the steel member the same value as for hollow encasement without a clearance may be adopted.

NOTE : Some design values of the section factor A_p/V for insulated steel members are given in table 4.3.

(5) For moist fire protection materials the calculation of the steel temperature increase $\Delta\theta_a$ may be modified to allow for a time delay in the rise of the steel temperature when it reaches 100°C . This delay time should be determined by a method conforming with ENV 13381-4.

(6) As an alternative to 4.2.5.2 (1), the uniform temperature of an insulated steel member after a given time duration of standard fire exposure may be obtained using design flow charts derived in conformity with ENV 13381-4.

Table 4.3: Section factor A_p/V for steel members insulated by fire protection material

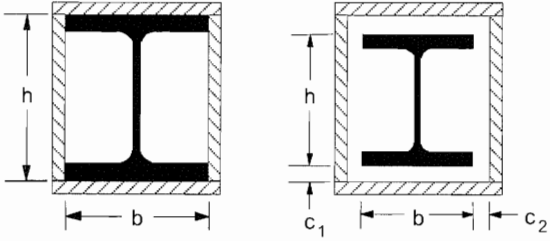
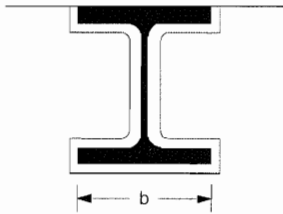
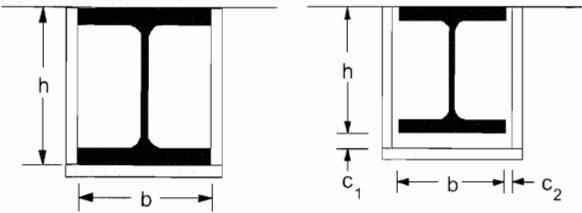
Sketch	Description	Section factor (A_p/V)
	Contour encasement of uniform thickness	$\frac{\text{steel perimeter}}{\text{steel cross-section area}}$
	Hollow encasement of uniform thickness) ¹	$\frac{2(b + h)}{\text{steel cross-section area}}$
	Contour encasement of uniform thickness, exposed to fire on three sides	$\frac{\text{steel perimeter} - b}{\text{steel cross-section area}}$
	Hollow encasement of uniform thickness, exposed to fire on three sides) ¹	$\frac{2h + b}{\text{steel cross-section area}}$

¹ The clearance dimensions c_1 and c_2 should not normally exceed $h/4$

4.2.5.3 Internal steelwork in a void that is protected by heat screens

- (1) The provisions given below apply to both of the following cases:
- steel members in a void that have a floor on top and by a horizontal heat screen below, and
 - steel members in a void that have vertical heat screens on both sides,

provided in both cases that there is a gap between the heat screen and the member. They do not apply if the heat screen is in direct contact with the member.

(2) For internal steelwork protected by heat screens, the calculation of the steel temperature increase $\Delta\theta_a$ should be based on the methods given in 4.2.5.1 or 4.2.5.2 as appropriate, taking the ambient gas temperature $\theta_{g,t}$ as equal to the gas temperature in the void.

(3) The properties and performance of the heat screens used in design should have been determined using a test procedure conforming with ENV 13381-1 or ENV 13381-2 as appropriate.

(4) The temperature development in the void in which the steel members are situated should be determined from measurement according to ENV 13381-1 or ENV 13381-2 as appropriate.

4.2.5.4 External steelwork

(1) The temperature of external steelwork should be determined taking into account:

- the radiative heat flux from the fire compartment;
- the radiative heat flux and the convective heat flux from the flames emanating from openings;
- the radiative and convective heat loss from the steelwork to the ambient atmosphere;
- the sizes and locations of the structural members.

(2) Heat screens may be provided on one, two or three sides of an external steel member in order to protect it from radiative heat transfer.

(3) Heat screens should be either:

- directly attached to that side of the steel member that it is intended to protect, or
- large enough to fully screen that side from the expected radiative heat flux.

(4) Heat screens referred to in annex B should be non-combustible and have a fire resistance of at least EI 30 according to EN ISO 13501-2.

(5) The temperature in external steelwork protected by heat screens should be determined as required in 4.2.5.4(1), assuming that there is no radiative heat transfer to those sides that are protected by heat screens.

(6) Calculations may be based on steady state conditions resulting from a stationary heat balance using the methods given in annex B.

(7) Design using annex B of this Part 1-2 of EN 1993 should be based on the model given in annex B of EN 1991-1-2 describing the compartment fire conditions and the flames emanating from openings, on which the calculation of the radiative and convective heat fluxes should be based.

4.3 Advanced calculation models

4.3.1 General

- (1) Advanced calculation methods should provide a realistic analysis of structures exposed to fire. They should be based on fundamental physical behaviour in such a way as to lead to a reliable approximation of the expected behaviour of the relevant structural component under fire conditions.
- (2) Any potential failure modes not covered by the advanced calculation method (including local buckling and failure in shear) should be eliminated by appropriate means.
- (3) Advanced calculation methods should include separate calculation models for the determination of:
 - the development and distribution of the temperature within structural members (thermal response model);
 - the mechanical behaviour of the structure or of any part of it (mechanical response model).
- (4) Advanced calculation methods may be used in association with any heating curve, provided that the material properties are known for the relevant temperature range.
- (5) Advanced calculation methods may be used with any type of cross-section.

4.3.2 Thermal response

- (1) Advanced calculation methods for thermal response should be based on the acknowledged principles and assumptions of the theory of heat transfer.
- (2) The thermal response model should consider:
 - the relevant thermal actions specified in EN 1991-1-2;
 - the variation of the thermal properties of the material with the temperature, see section 3.
- (3) The effects of non-uniform thermal exposure and of heat transfer to adjacent building components may be included where appropriate.
- (4) The influence of any moisture content and of any migration of the moisture within the fire protection material may conservatively be neglected.

4.3.3 Mechanical response

- (1) Advanced calculation methods for mechanical response should be based on the acknowledged principles and assumptions of the theory of structural mechanics, taking into account the changes of mechanical properties with temperature.
- (2) The effects of thermally induced strains and stresses both due to temperature rise and due to temperature differentials, should be considered.
- (3) The model for mechanical response should also take account of:
 - the combined effects of mechanical actions, geometrical imperfections and thermal actions;
 - the temperature dependent mechanical properties of the material, see section 3;
 - geometrical non-linear effects;
 - the effects of non-linear material properties, including the unfavourable effects of loading and unloading on the structural stiffness.
- (4) Provided that the stress-strain relationships given in section 3 are used, the effects of transient thermal creep need not be given explicit consideration.

BS EN 1993-1-2:2005
EN 1993-1-2:2005 (E)

- (5) The deformations at ultimate limit state implied by the calculation method should be limited to ensure that compatibility is maintained between all parts of the structure.
- (6) The design should take into account the ultimate limit state beyond which the calculated deformations of the structure would cause failure due to the loss of adequate support to one of the members.
- (7) For the analysis of isolated vertical members a sinusoidal initial imperfection with a maximum value of $h/1000$ at mid-height should be used, when not specified by relevant product standards.

4.3.4 Validation of advanced calculation models

- (1) A verification of the accuracy of the calculation models should be made on basis of relevant test results.
- (2) Calculation results may refer to temperatures, deformations and fire resistance times.
- (3) The critical parameters should be checked to ensure that the model complies with sound engineering principles, by means of a sensitivity analysis.
- (4) Critical parameters may refer, for example to the buckling length, the size of the elements, the load level.

Annex A [normative] Strain-hardening of carbon steel at elevated temperatures

(1) For temperatures below 400°C, the alternative strain-hardening option mentioned in 3.2 may be used as follows:

- for $0,02 < \varepsilon < 0,04$:

$$\sigma_a = 50(f_{u,\theta} - f_{y,\theta})\varepsilon + 2f_{y,\theta} - f_{u,\theta} \quad (\text{A.1a})$$

- for $0,04 \leq \varepsilon \leq 0,15$:

$$\sigma_a = f_{u,\theta} \quad (\text{A.1b})$$

- for $0,15 < \varepsilon < 0,20$:

$$\boxed{\text{AC2}} \sigma_a \boxed{\text{AC2}} = f_{u,\theta} [1 - 20(\varepsilon - 0,15)] \quad (\text{A.1c})$$

- for $\varepsilon \geq 0,20$:

$$\sigma_a = 0,00 \quad (\text{A.1d})$$

where:

$f_{u,\theta}$ is the ultimate strength at elevated temperature, allowing for strain-hardening.

NOTE: The alternative stress-strain relationship for steel, allowing for strain hardening, is illustrated in figure A.1.

(2) The ultimate strength at elevated temperature, allowing for strain hardening, should be determined as follows:

- for $\theta_a < 300^\circ\text{C}$:

$$f_{u,\theta} = 1,25f_{y,\theta} \quad (\text{A.2a})$$

- for $300^\circ\text{C} \leq \theta_a < 400^\circ\text{C}$:

$$\boxed{\text{AC2}} f_{u,\theta} = f_{y,\theta} (2 - 0,0025 \theta_a) \boxed{\text{AC2}} \quad (\text{A.2b})$$

- for $\theta_a \geq 400^\circ\text{C}$:

$$f_{u,\theta} = f_{y,\theta} \quad (\text{A.2c})$$

NOTE: The variation of the alternative stress-strain relationship with temperature is illustrated in figure A.2.

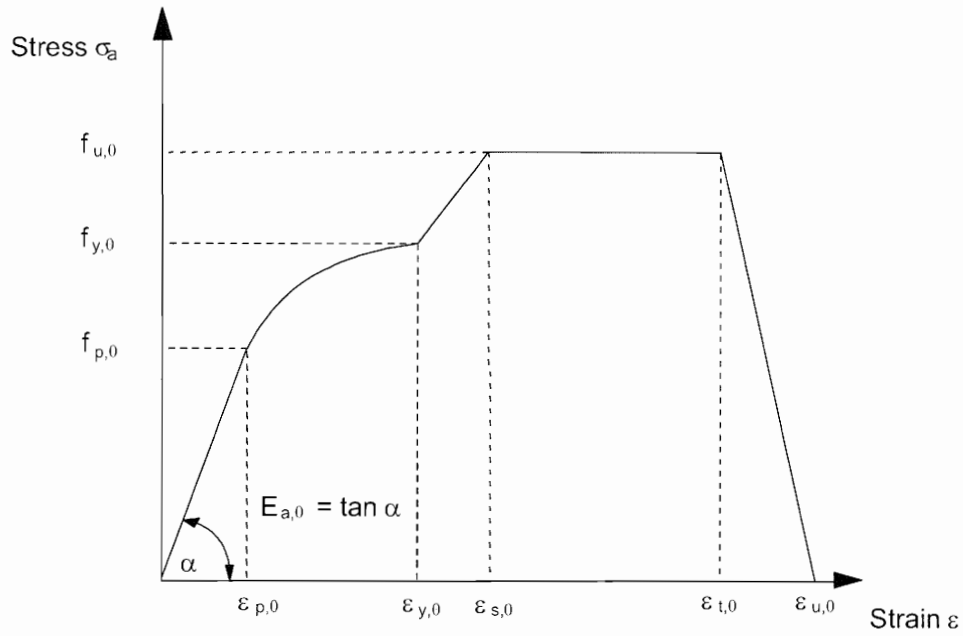

Figure A.1: Alternative stress-strain relationship for steel allowing for strain-hardening

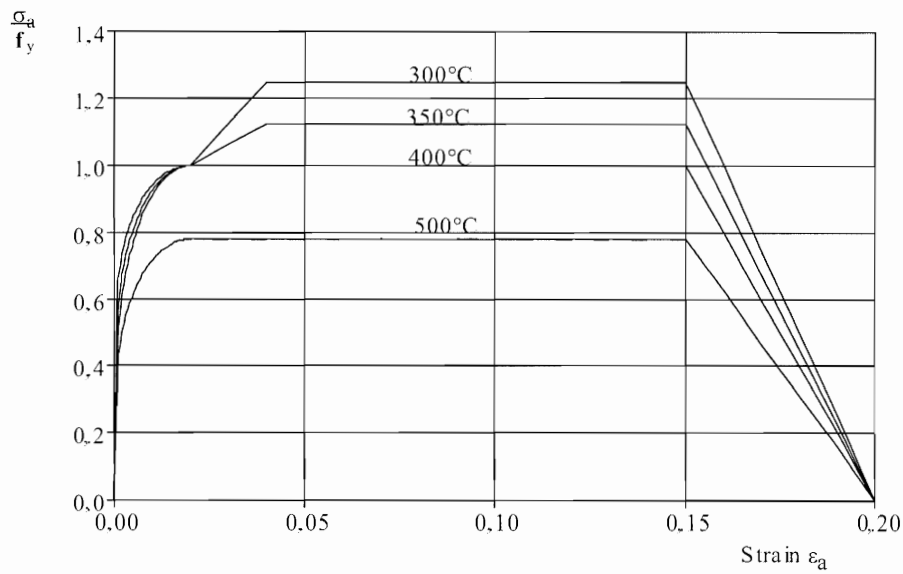

Figure A.2: Alternative stress-strain relationships for steel at elevated temperatures, allowing for strain hardening

Annex B [normative] Heat transfer to external steelwork

B.1 General

B.1.1 Basis

- (1) In this annex B, the fire compartment is assumed to be confined to one storey only. All windows or other similar openings in the fire compartment are assumed to be rectangular.
- (2) The determination of the temperature of the compartment fire, the dimensions and temperatures of the flames projecting from the openings, and the radiation and convection parameters should be performed according to annex B of EN 1991-1-2.
- (3) A distinction should be made between members not engulfed in flame and members engulfed in flame, depending on their locations relative to the openings in the walls of the fire compartment.
- (4) A member that is not engulfed in flame should be assumed to receive radiative heat transfer from all the openings in that side of the fire compartment and from the flames projecting from all these openings.
- (5) A member that is engulfed in flame should be assumed to receive convective heat transfer from the engulfing flame, plus radiative heat transfer from the engulfing flame and from the fire compartment opening from which it projects. The radiative heat transfer from other flames and from other openings may be neglected.

B.1.2 Conventions for dimensions

- (1) The convention for geometrical data may be taken from figure B.1.

B.1.3 Heat balance

- (1) For a member not engulfed in flame, the average temperature of the steel member T_m [K] should be determined from the solution of the following heat balance:

$$\sigma T_m^4 + \alpha T_m = \Sigma I_z + \Sigma I_f + 293\alpha \quad (\text{B.1})$$

where:

- σ is the Stefan Boltzmann constant [$56,7 \times 10^{-12}$ kW/m²K⁴];
- α is the convective heat transfer coefficient [kW/m²K];
- I_z is the radiative heat flux from a flame [kW/m²];
- I_f is the radiative heat flux from an opening [kW/m²].

- (2) The convective heat transfer coefficient α should be obtained from annex B of EN 1991-1-2 for the 'no forced draught' or the 'forced draught' condition as appropriate, using an effective cross-sectional dimension $d = (d_1 + d_2)/2$.

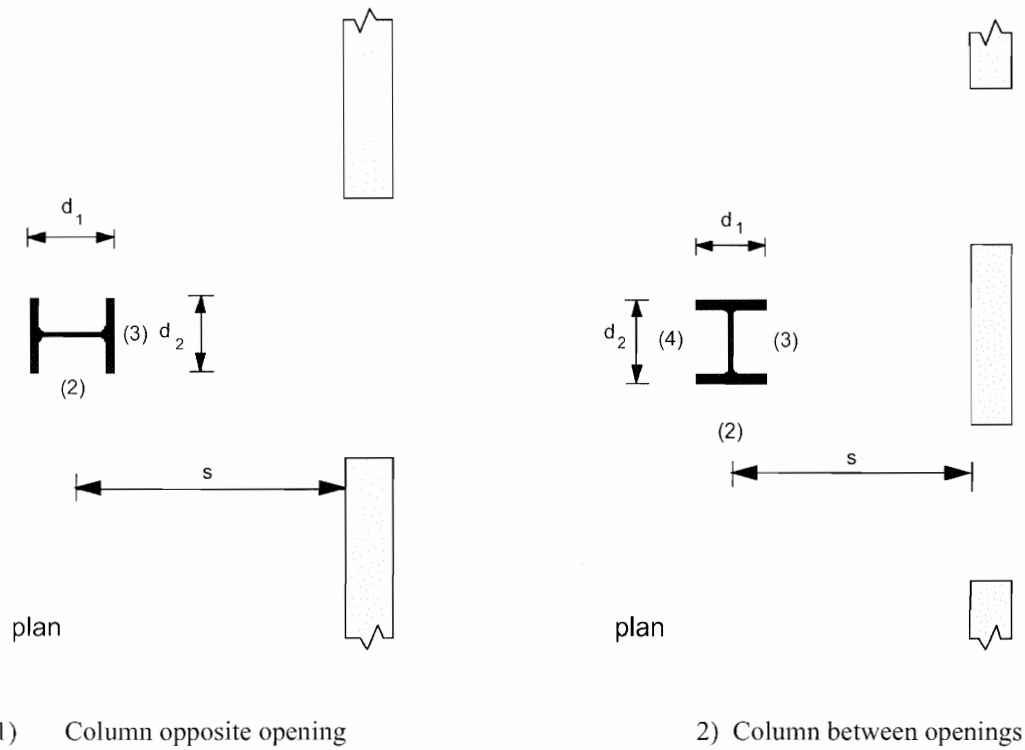

a) Columns

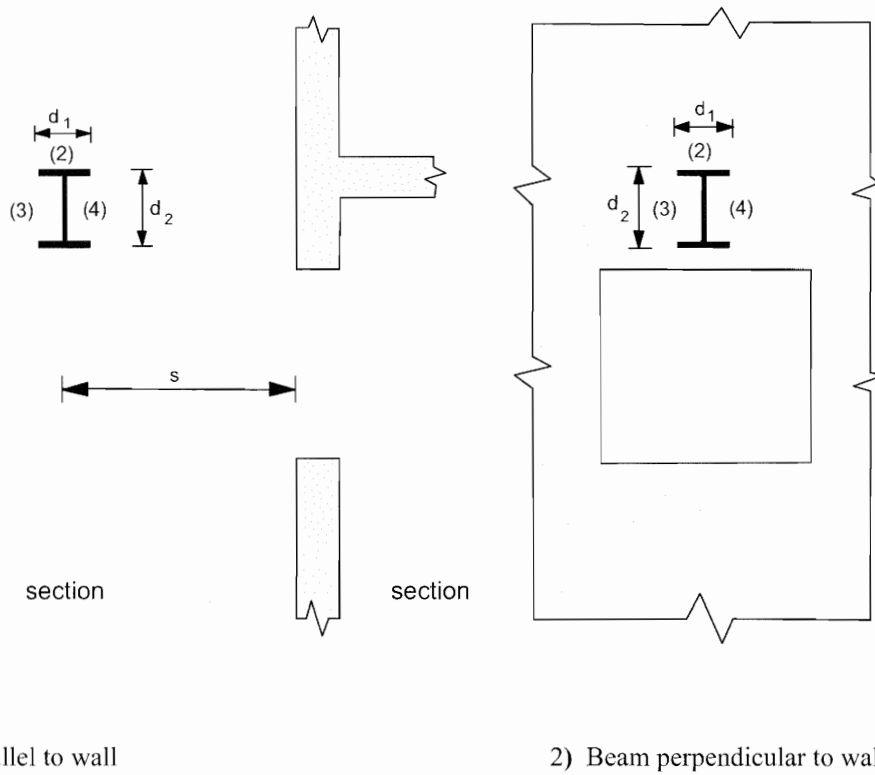

b) Beams

Figure B.1: Member dimensions and faces

(3) For a member engulfed in flame, the average temperature of the steel member T_m [K] should be determined from the solution of the following heat balance:

$$\sigma T_m^4 + \alpha T_m = I_z + I_f + \alpha T_z \quad (\text{B.2})$$

where:

- T_z is the flame temperature [K];
- I_z is the radiative heat flux from the flame [kW/m²];
- I_f is the radiative heat flux from the corresponding opening [kW/m²].

(4) The radiative heat flux I_z from flames should be determined according to the situation and type of member as follows:

- Columns not engulfed in flame: see B.2;
- Beams not engulfed in flame: see B.3;
- Columns engulfed in flame: see B.4;
- Beams fully or partially engulfed in flame: see B.5.

Other cases may be treated analogously, using appropriate adaptations of the treatments given in B.2 to B.5.

(5) The radiative heat flux I_f from an opening should be determined from:

$$I_f = \phi_f \varepsilon_f (1 - a_z) \sigma T_f^4 \quad (\text{B.3})$$

where:

- ϕ_f is the overall configuration factor of the member for radiative heat transfer from that opening;
- ε_f is the emissivity of the opening;
- a_z is the absorptivity of the flames;
- T_f is the temperature of the fire [K] from annex B of EN 1991-1-2.

(6) The emissivity ε_f of an opening should be taken as unity, see annex B of EN 1991-1-2.

(7) The absorptivity a_z of the flames should be determined from B.2 to B.5 as appropriate.

B.1.4 Overall configuration factors

(1) The overall configuration factor ϕ_r of a member for radiative heat transfer from an opening should be determined from:

$$\phi_r = \frac{(C_1\phi_{f,1} + C_2\phi_{f,2})d_1 + (C_3\phi_{f,3} + C_4\phi_{f,4})d_2}{(C_1 + C_2)d_1 + (C_3 + C_4)d_2} \quad (\text{B.4})$$

where:

- $\phi_{r,i}$ is the configuration factor of member face i for that opening, see annex G of EN 1991-1-2;
- d_i is the cross-sectional dimension of member face i ;
- C_i is the protection coefficient of member face i as follows:
 - for a protected face: $C_i = 0$
 - for an unprotected face: $C_i = 1$

(2) The configuration factor $\phi_{r,i}$ for a member face from which the opening is not visible should be taken as zero.

(3) The overall configuration factor ϕ_z of a member for radiative heat transfer from a flame should be determined from:

$$\phi_z = \frac{(C_1\phi_{z,1} + C_2\phi_{z,2})d_1 + (C_3\phi_{z,3} + C_4\phi_{z,4})d_2}{(C_1 + C_2)d_1 + (C_3 + C_4)d_2} \quad (\text{B.5})$$

where:

- $\phi_{z,i}$ is the configuration factor of member face i for that flame, see annex G of EN 1991-1-2.

(4) The configuration factors $\phi_{z,i}$ of individual member faces for radiative heat transfer from flames may be based on equivalent rectangular flame dimensions. The dimensions and locations of equivalent rectangles representing the front and sides of a flame for this purpose should be determined as given in B.2 for columns and B.3 for beams. For all other purposes, the flame dimensions from annex B of EN 1991-1-2 should be used.

(5) The configuration factor $\phi_{z,i}$ for a member face from which the flame is not visible should be taken as zero.

(6) A member face may be protected by a heat screen, see 4.2.5.4. A member face that is immediately adjacent to the compartment wall may also be treated as protected, provided that there are no openings in that part of the wall. All other member faces should be treated as unprotected.

B.2 Column not engulfed in flame

B.2.1 Radiative heat transfer

(1) A distinction should be made between a column located opposite an opening and a column located between openings.

NOTE: Illustration are given in figure B.2

(2) If the column is opposite an opening the radiative heat flux I_z from the flame should be determined from:

$$I_z = \phi_z \varepsilon_z \sigma T_z^4 \quad (\text{B.6})$$

where:

- ϕ_z is the overall configuration factor of the column for heat from the flame, see B.1.4;
- ε_z is the emissivity of the flame, see B.2.2;
- T_z is the flame temperature [K] from B.2.3.

NOTE: Illustration are given in figure B.3.

(3) If the column is between openings the total radiative heat flux I_z from the flames on each side should be determined from:

$$I_z = (\phi_{z,m} \varepsilon_{z,m} + \phi_{z,n} \varepsilon_{z,n}) \sigma T_z^4 \quad (\text{B.7})$$

where:

- $\phi_{z,m}$ is the overall configuration factor of the column for heat from flames on side m , see B.1.4;
- $\phi_{z,n}$ is the overall configuration factor of the column for heat from flames on side n , see B.1.4;
- $\varepsilon_{z,m}$ is the total emissivity of the flames on side m , see B.2.2;
- $\varepsilon_{z,n}$ is the total emissivity of the flames on side n , see B.2.2.

NOTE: Illustration are given in figure B.4.

B.2.2 Flame emissivity

(1) If the column is opposite an opening, the flame emissivity ε_z should be determined from the expression for ε given in annex B of EN 1991-1-2, using the flame thickness λ at the level of the top of the openings. Provided that there is no awning or balcony above the opening λ may be taken as follows:

- for the 'no forced draught' condition:

$$\lambda = 2h/3 \quad (\text{B.8a})$$

- for the 'forced draught' condition:

$$\lambda = x \text{ but } \lambda \leq hx/z \quad (\text{B.8b})$$

where h , x and z are as given in annex B of EN 1991-1-2.

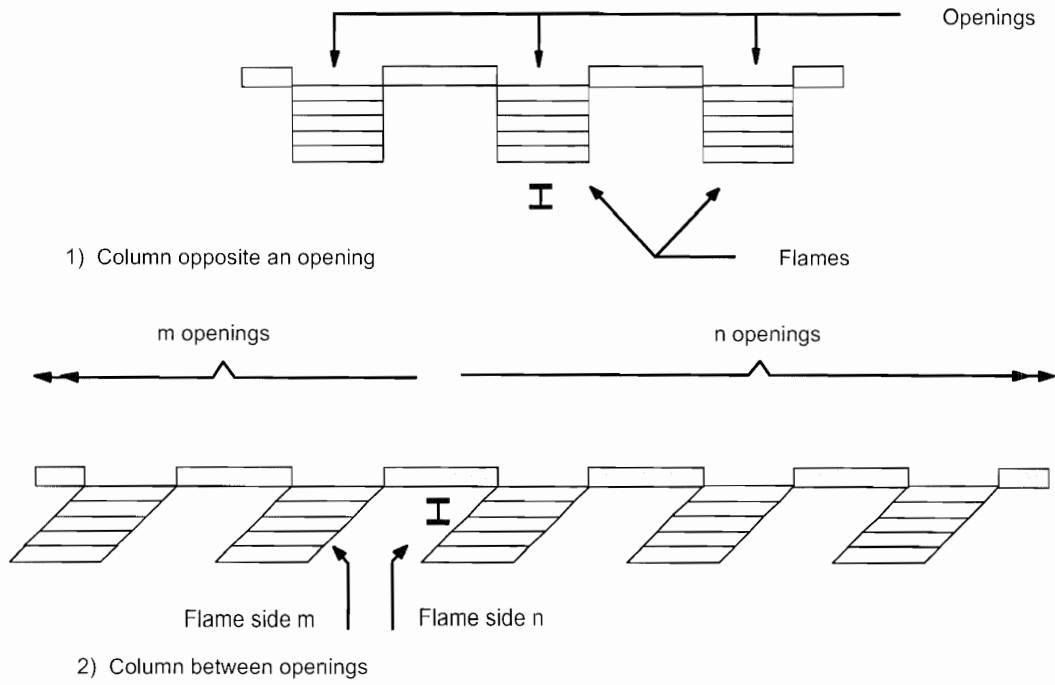

a) 'No forced draught' condition

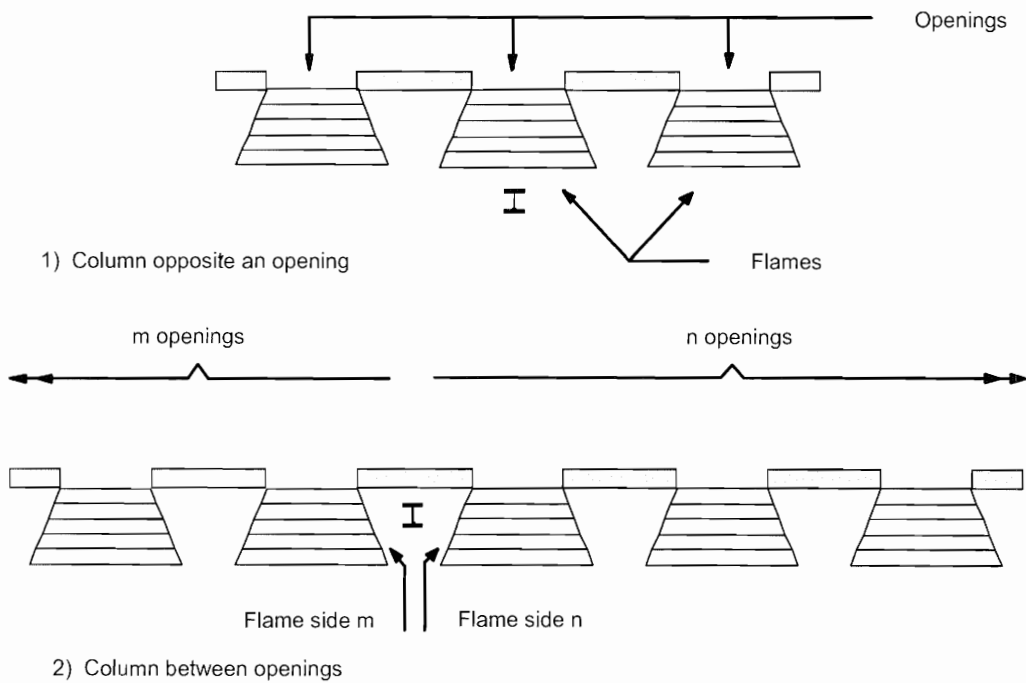

b) 'Forced draught' condition

Figure B.2: Column positions

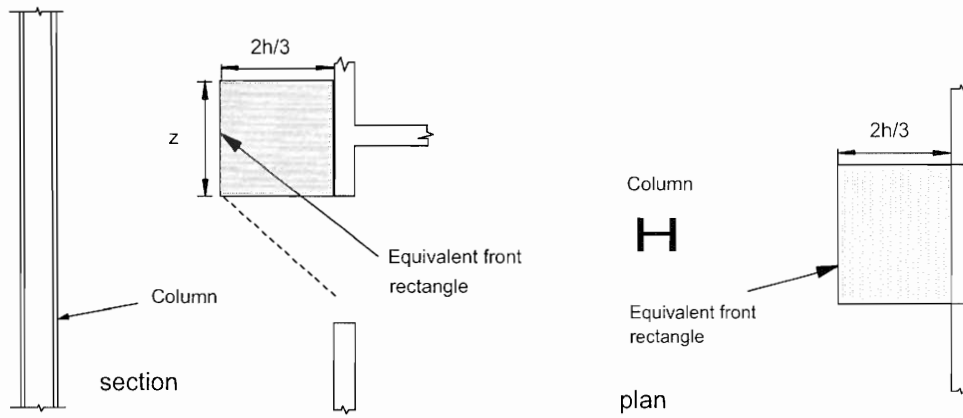

1) wall above and $h < 1,25w$

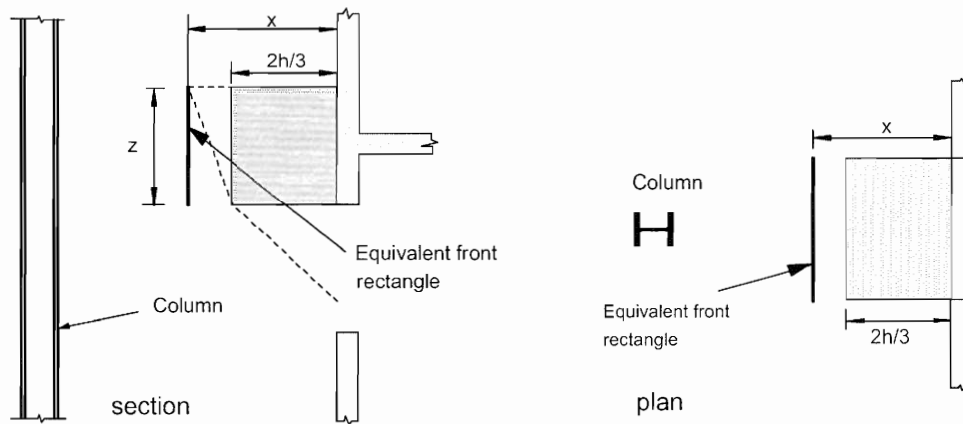

2) wall above and $h > 1,25w$ or no wall above

a) 'No forced draught'

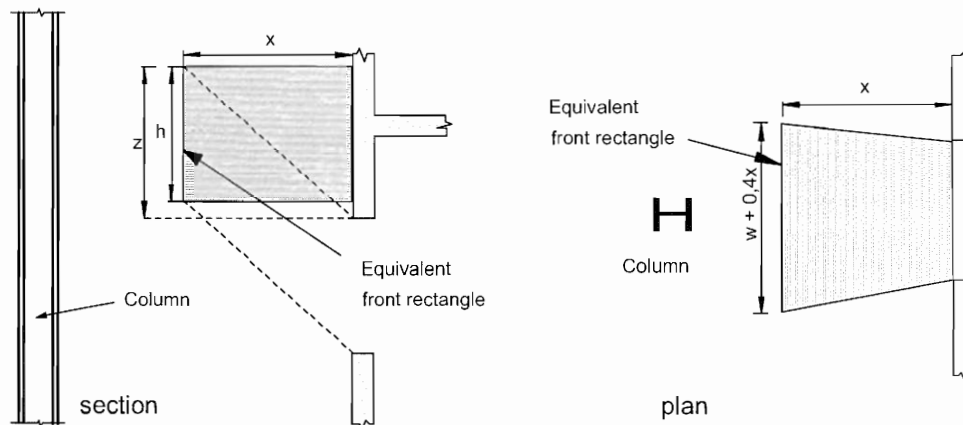

b) 'Forced draught'

Figure B.3: Column opposite opening

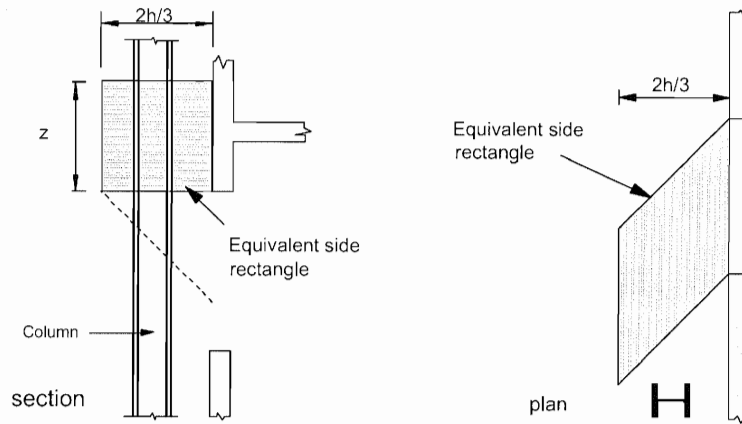

1) wall above and $h < 1,25w$

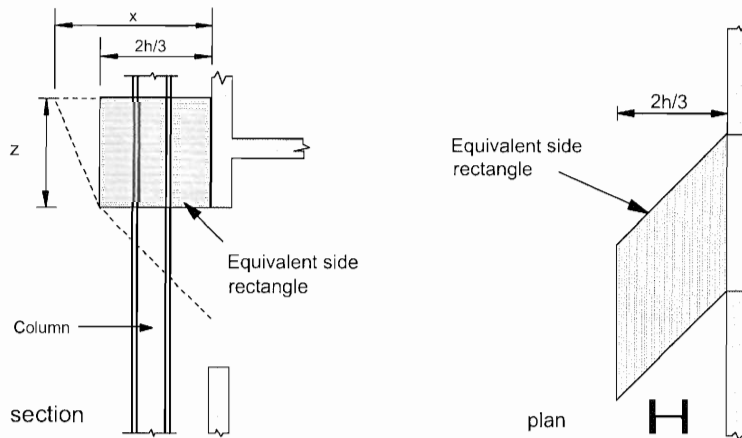

2) wall above and $h > 1,25w$ or no wall above

a) 'No forced draught'

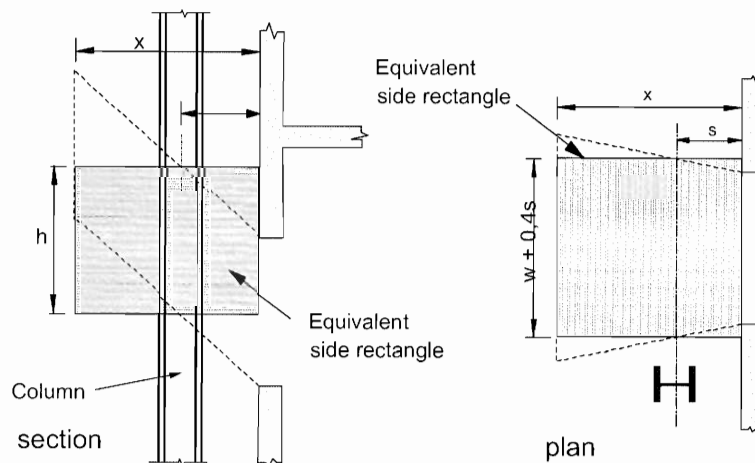

b) 'Forced draught'

Figure B.4: Column between openings

(2) If the column is between two openings, the total emissivities $\varepsilon_{z,m}$ and $\varepsilon_{z,n}$ of the flames on sides m and n should be determined from the expression for ε given in annex B of EN 1991-1-2 using a value for the total flame thickness λ as follows:

- for side m : $\lambda = \sum_{i=1}^m \lambda_i$ (B.9a)

- for side n : $\lambda = \sum_{i=1}^n \lambda_i$ (B.9b)

where:

m is the number of openings on side m ;

n is the number of openings on side n ;

λ_i is the flame thickness for opening i .

(3) The flame thickness λ_i should be taken as follows:

- for the 'no forced draught' condition:

$$\lambda_i = w_i \quad (\text{B.10a})$$

- for the 'forced draught' condition:

$$\lambda_i = w_i + 0,4s \quad (\text{B.10b})$$

where:

w_i is the width of the opening;

s is the horizontal distance from the centreline of the column to the wall of the fire compartment, see figure B.1.

B.2.3 Flame temperature

(1) The flame temperature T_z should be taken as the temperature at the flame axis obtained from the expression for T_z given in annex B of EN 1991-1-2, for the 'no forced draught' condition or the 'forced draught' condition as appropriate, at a distance l from the opening, measured along the flame axis, as follows:

- for the 'no forced draught' condition:

$$l = h/2 \quad (\text{B.11a})$$

- for the 'forced draught' condition:

- for a column opposite an opening:

$$l = 0 \quad (\text{B.11b})$$

- for a column between openings l is the distance along the flame axis to a point at a horizontal distance s from the wall of the fire compartment. Provided that there is no awning or balcony above the opening:

$$l = sX/x \quad (\text{B.11c})$$

where X and x are as given in annex B of EN 1991-1-2.

B.2.4 Flame absorptivity

- (1) For the 'no forced draught' condition, the flame absorptivity a_z should be taken as zero.
- (2) For the 'forced draught' condition, the flame absorptivity a_z should be taken as equal to the emissivity ε_z of the relevant flame, see B.2.2.

B.3 Beam not engulfed in flame

B.3.1 Radiative heat transfer

- (1) Throughout B.3 it is assumed that the level of the bottom of the beam is not below the level of the top of the openings in the fire compartment.
- (2) A distinction should be made between a beam that is parallel to the external wall of the fire compartment and a beam that is perpendicular to the external wall of the fire compartment, see figure B.5.
- (3) If the beam is parallel to the external wall of the fire compartment, the average temperature of the steel member T_m should be determined for a point in the length of the beam directly above the centre of the opening. For this case the radiative heat flux I_z from the flame should be determined from:

$$I_z = \phi_z \varepsilon_z \sigma T_z^4 \quad (\text{B.12})$$

where:

- ϕ_z is the overall configuration factor for the flame directly opposite the beam, see B.1.4;
- ε_z is the flame emissivity, see B.3.2;
- T_z is the flame temperature from B.3.3 [K].

- (4) If the beam is perpendicular to the external wall of the fire compartment, the average temperature in the beam should be determined at a series of points every 100 mm along the length of the beam. The average temperature of the steel member T_m should then be taken as the maximum of these values. For this case the radiative heat flux I_z from the flames should be determined from:

$$I_z = (\phi_{z,m} \varepsilon_{z,m} + \phi_{z,n} \varepsilon_{z,n}) \sigma T_z^4 \quad (\text{B.13})$$

where:

- $\phi_{z,m}$ is the overall configuration factor of the beam for heat from flames on side m , see B.3.2;
- $\phi_{z,n}$ is the overall configuration factor of the beam for heat from flames on side n , see B.3.2;
- $\varepsilon_{z,m}$ is the total emissivity of the flames on side m , see B.3.3;
- $\varepsilon_{z,n}$ is the total emissivity of the flames on side n , see B.3.3;
- T_z is the flame temperature [K], see B.3.4.

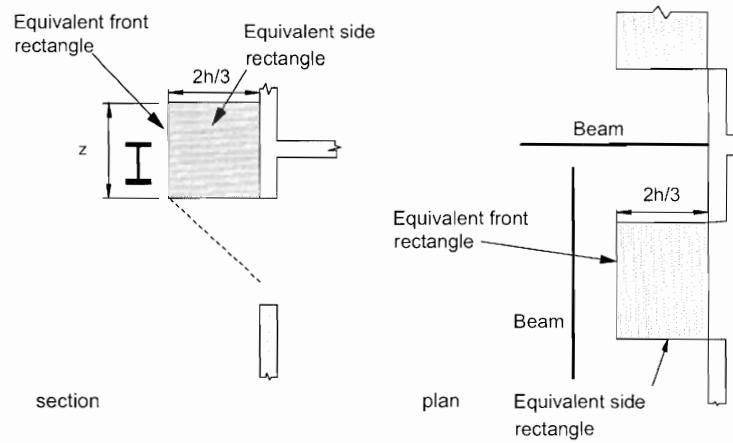

1) wall above and $h < 1,25w$

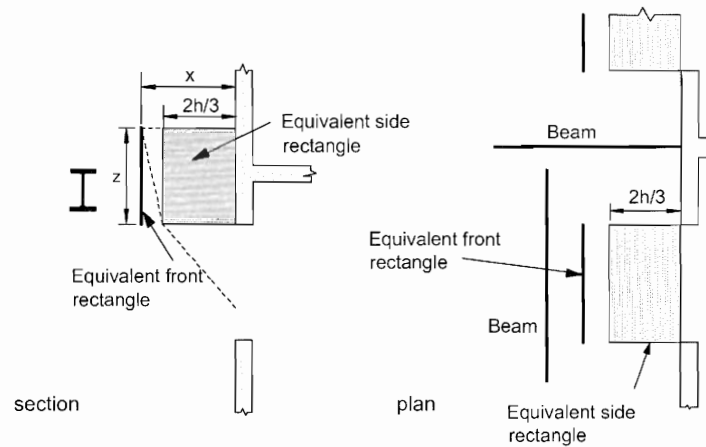

2) wall above and $h > 1,25w$ or no wall above

a) 'No forced draught'

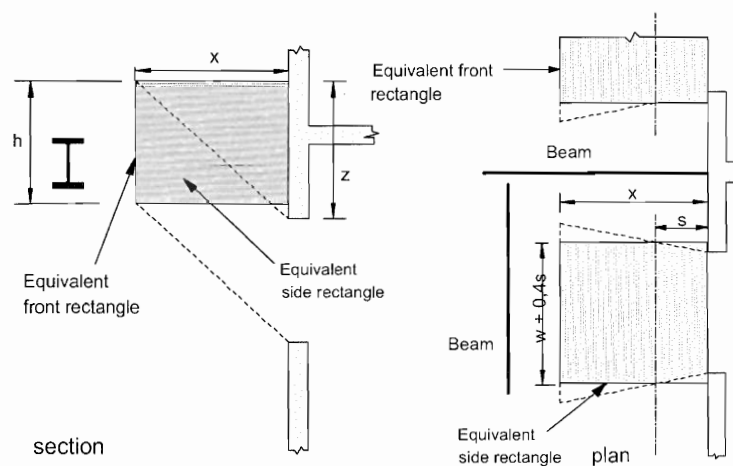

b) 'Forced draught'

Figure B.5: Beam not engulfed in flame

B.3.2 Flame emissivity

(1) If the beam is parallel to the external wall of the fire compartment, above an opening, the flame emissivity ε_z should be determined from the expression for ε given in annex B of EN 1991-1-2, using a value for the flame thickness λ at the level of the top of the openings. Provided that there is no awning or balcony above the opening λ may be taken as follows:

- for the 'no forced draught' condition:

$$\lambda = 2h/3 \quad (\text{B.14a})$$

- for the 'forced draught' condition:

$$\lambda = x \text{ but } \lambda \leq hx/z \quad (\text{B.14b})$$

where h , x and z are as given in annex B of EN 1991-1-2

(2) If the beam is perpendicular to the external wall of the fire compartment, between two openings, the total emissivities $\varepsilon_{z,m}$ and $\varepsilon_{z,n}$ of the flames on sides m and n should be determined from the expression for ε given in annex B of EN 1991-1-2 using a value for the flame thickness λ as follows:

- for side m : $\lambda = \sum_{i=1}^m \lambda_i \quad (\text{B.15a})$

- for side n : $\lambda = \sum_{i=1}^n \lambda_i \quad (\text{B.15b})$

where:

- m is the number of openings on side m ;
- n is the number of openings on side n ;
- λ_i is the width of opening i .

(3) The flame thickness λ_i should be taken as follows:

- for the 'no forced draught' condition:

$$\lambda_i = w_i \quad (\text{B.16a})$$

- for the 'forced draught' condition:

$$\lambda_i = w_i + 0,4s \quad (\text{B.16b})$$

where:

- w_i is the width of the opening;
- s is the horizontal distance from the wall of the fire compartment to the point under consideration on the beam, see figure B.5.

B.3.3 Flame temperature

(1) The flame temperature T_z should be taken as the temperature at the flame axis obtained from the expression for T_z given in annex B of EN 1991-1-2, for the 'no forced draught' or 'forced draught' condition as appropriate, at a distance l from the opening, measured along the flame axis, as follows:

- for the 'no forced draught' condition:

$$l = h/2 \quad (\text{B.17a})$$

- for the 'forced draught' condition:

- for a beam parallel to the external wall of the fire compartment, above an opening:

$$l = 0 \quad (\text{B.17b})$$

- for a beam perpendicular to the external wall of the fire compartment, between openings l is the distance along the flame axis to a point at a horizontal distance s from the wall of the fire compartment. Provided that there is no awning or balcony above the opening:

$$l = sX/x \quad (\text{B.17c})$$

where X and x are as given in annex B of EN 1991-1-2.

B.3.4 Flame absorptivity

(1) For the 'no forced draught' condition, the flame absorptivity a_z should be taken as zero.

(2) For the 'forced draught' condition, the flame absorptivity a_z should be taken as equal to the emissivity ε_z of the relevant flame, see B.3.2.

B.4 Column engulfed in flame

(1) The radiative heat flux I_z from the flames should be determined from:

$$\boxed{\text{AC}_2} I_z = \frac{(I_{z,1} + I_{z,2}) \cdot d_1 + (I_{z,3} + I_{z,4}) \cdot d_2}{(C_1 + C_2) \cdot d_1 + (C_3 + C_4) \cdot d_2} \quad \boxed{\text{AC}_2} \quad (\text{B.18})$$

with:

$$I_{z,1} = C_1 \varepsilon_{z,1} \sigma T_z^4$$

$$I_{z,2} = C_2 \varepsilon_{z,2} \sigma T_z^4$$

$$I_{z,3} = C_3 \varepsilon_{z,3} \sigma T_o^4$$

$$I_{z,4} = C_4 \varepsilon_{z,4} \sigma T_z^4$$

where:

$I_{z,i}$ is the radiative heat flux from the flame to column face i ;

$\varepsilon_{z,i}$ is the emissivity of the flames with respect to face i of the column;

i is the column face indicator (1), (2), (3) or (4);

C_i is the protection coefficient of member face i , see B.1.4;

T_z is the flame temperature [K];

T_o is the flame temperature at the opening [K] from annex B of EN 1991-1-2.

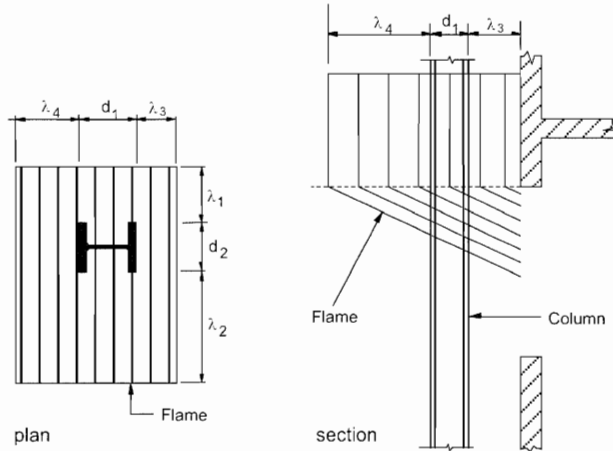

a) 'No forced draught' condition

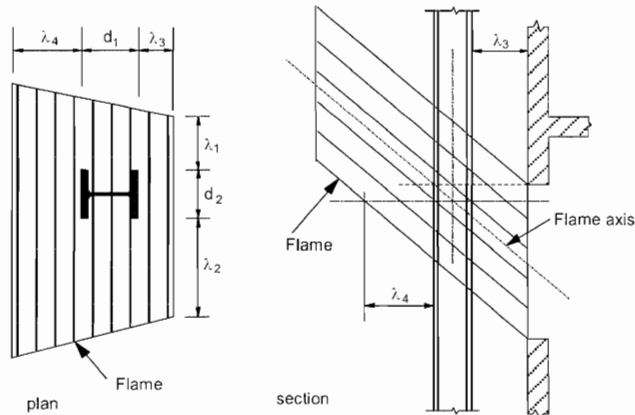

1) Flame axis intersects column axis below top of opening

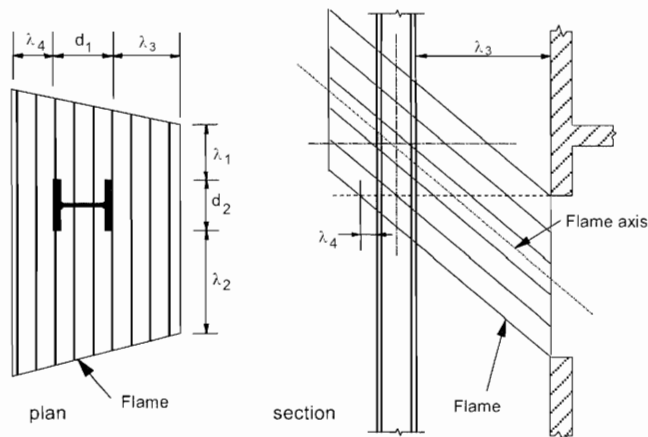

2) Flame axis intersects column axis above top of opening

b) 'Forced draught' condition

Figure B.6: Column engulfed in flame

(2) The emissivity of the flames $\varepsilon_{z,i}$ for each of the faces 1, 2, 3 and 4 of the column should be determined from the expression for ε given in annex B of EN 1991-1-2, using a flame thickness λ equal to the dimension λ_i indicated in figure B.6 corresponding to face i of the column.

(3) For the 'no forced draught' condition the values of λ_i at the level of the top of the opening should be used, see figure B.6(a).

(4) For the 'forced draught' condition, if the level of the intersection of the flame axis and the column centreline is below the level of the top of the opening, the values of λ_i at the level of the intersection should be used, see figure B.6(b)(1). Otherwise the values of λ_i at the level of the top of the opening should be used, see figure B.6(b)(2), except that if $\lambda_4 < 0$ at this level, the values at the level where $\lambda_4 = 0$ should be used.

(5) The flame temperature T_z should be taken as the temperature at the flame axis obtained from the expression for T_z given in annex B of EN 1991-1-2 for the 'no forced draught' or 'forced draught' condition as appropriate, at a distance l from the opening, measured along the flame axis, as follows:

- for the 'no forced draught' condition:

$$l = h/2 \quad (\text{B.19a})$$

- for the 'forced draught' condition, l is the distance along the flame axis to the level where λ_i is measured. Provided that there is no balcony or awning above the opening:

$$l = (\lambda_3 + 0,5d_1)X/x \text{ but } l \leq 0,5hX/z \quad (\text{B.19b})$$

where h , X , x and z are as given in annex B of EN 1991-1-2.

(6) The absorptivity a_z of the flames should be determined from:

$$a_z = \frac{\varepsilon_{z,1} + \varepsilon_{z,2} + \varepsilon_{z,3}}{3} \quad (\text{B.20})$$

where $\varepsilon_{z,1}$, $\varepsilon_{z,2}$ and $\varepsilon_{z,3}$ are the emissivities of the flame for column faces 1, 2, and 3.

B.5 Beam fully or partially engulfed in flame

B.5.1 Radiative heat transfer

B.5.1.1 General

- (1) Throughout B.5 it is assumed that the level of the bottom of the beam is not below the level of the top of the adjacent openings in the fire compartment.
- (2) A distinction should be made between a beam that is parallel to the external wall of the fire compartment and a beam that is perpendicular to the external wall of the fire compartment, see figure B.7.
- (3) If the beam is parallel to the external wall of the fire compartment, its average temperature T_m should be determined for a point in the length of the beam directly above the centre of the opening.
- (4) If the beam is perpendicular to the external wall of the fire compartment, the value of the average temperature should be determined at a series of points every 100 mm along the length of the beam. The maximum of these values should then be adopted as the average temperature of the steel member T_m .
- (5) The radiative heat flux I_z from the flame should be determined from:

$$\boxed{AC2} I_z = \frac{(I_{z,1} + I_{z,2}) \cdot d_1 + (I_{z,3} + I_{z,4}) \cdot d_2}{(C_1 + C_2) \cdot d_1 + (C_3 + C_4) \cdot d_2} \quad \boxed{AC2} \quad (B.21)$$

where:

- $I_{z,i}$ is the radiative heat flux from the flame to beam face i ;
 i is the beam face indicator (1), (2), (3) or (4).

B.5.1.2 'No forced draught' condition

- (1) For the 'no forced draught' condition, a distinction should be made between those cases where the top of the flame is above the level of the top of the beam and those where it is below this level.
- (2) If the top of the flame is above the level of the top of the beam the following equations should be applied:

$$I_{z,1} = C_1 \varepsilon_{z,1} \sigma T_o^4 \quad (B.22a)$$

$$I_{z,2} = C_2 \varepsilon_{z,2} \sigma T_{z,2}^4 \quad (B.22b)$$

$$I_{z,3} = C_3 \varepsilon_{z,3} \sigma (T_{z,1}^4 + T_{z,2}^4) / 2 \quad (B.22c)$$

$$I_{z,4} = C_4 \varepsilon_{z,4} \sigma (T_{z,1}^4 + T_{z,2}^4) / 2 \quad (B.22d)$$

where:

- $\varepsilon_{z,i}$ is the emissivity of the flame with respect to face i of the beam, see B.5.2;
 T_o is the temperature at the opening [K] from annex B of EN 1991-1-2;
 $T_{z,1}$ is the flame temperature [K] from annex B of EN 1991-1-2, level with the bottom of the beam;
 $T_{z,2}$ is the flame temperature [K] from annex B of EN 1991-1-2, level with the top of the beam.

- (3) In the case of a beam parallel to the external wall of the fire compartment C_4 may be taken as zero if the beam is immediately adjacent to the wall, see figure B.7.

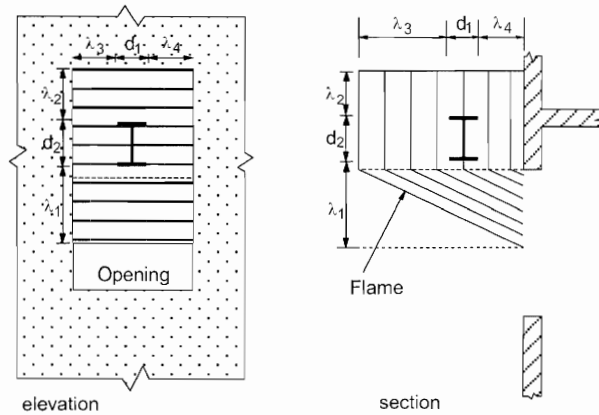

1) Beam perpendicular to wall

2) Beam parallel to wall

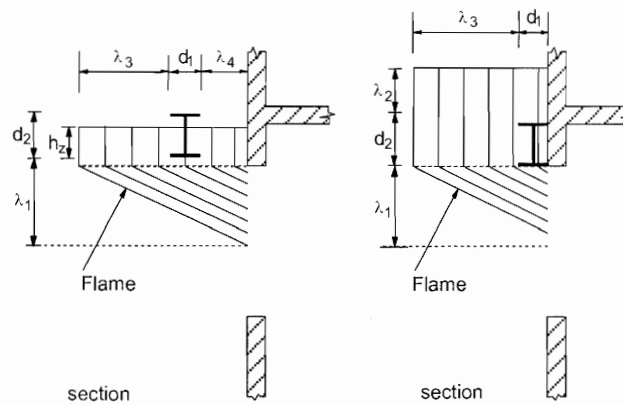

3) Top of flame below top of beam

4) Beam immediately adjacent to wall

a) 'No forced draught' condition

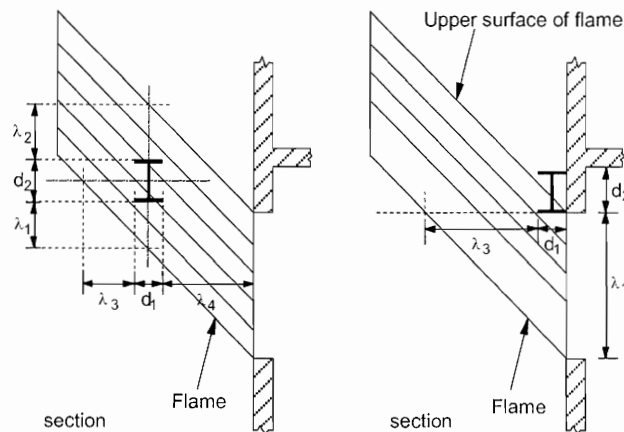

1) Beam not adjacent to wall

2) Beam immediately adjacent to wall

b) 'Forced draught' condition

Figure B.7: Beam engulfed in flame

(4) If the top of the flame is below the level of the top of the beam the following equations should be applied:

$$I_{z,1} = C_1 \varepsilon_{z,1} \sigma T_o^4 \quad (\text{B.23a})$$

$$I_{z,2} = 0 \quad (\text{B.23b})$$

$$I_{z,3} = (h_z/d_2) C_3 \varepsilon_{z,3} \sigma (T_{z,1}^4 + T_x^4)/2 \quad (\text{B.23c})$$

$$I_{z,4} = (h_z/d_2) C_4 \varepsilon_{z,4} \sigma (T_{z,1}^4 + T_x^4)/2 \quad (\text{B.23d})$$

where:

T_x is the flame temperature at the flame tip [813 K];
 h_z is the height of the top of the flame above the bottom of the beam.

B.5.1.3 'Forced draught' condition

(1) For the 'forced draught' condition, in the case of beams parallel to the external wall of the fire compartment a distinction should be made between those immediately adjacent to the wall and those not immediately adjacent to it.

NOTE: Illustrations are given in figure B.7.

(2) For a beam parallel to the wall, but not immediately adjacent to it, or for a beam perpendicular to the wall the following equations should be applied:

$$I_{z,1} = C_1 \varepsilon_{z,1} \sigma T_o^4 \quad (\text{B.24a})$$

$$I_{z,2} = C_2 \varepsilon_{z,2} \sigma T_{z,2}^4 \quad (\text{B.24b})$$

$$I_{z,3} = C_3 \varepsilon_{z,3} \sigma (T_{z,1}^4 + T_{z,2}^4)/2 \quad (\text{B.24c})$$

$$I_{z,4} = C_4 \varepsilon_{z,4} \sigma (T_{z,1}^4 + T_{z,2}^4)/2 \quad (\text{B.24d})$$

(3) If the beam is parallel to the wall and immediately adjacent to it, only the bottom face should be taken as engulfed in flame but one side and the top should be taken as exposed to radiative heat transfer from the upper surface of the flame, see figure B.7(b)(2). Thus:

$$I_{z,1} = C_1 \varepsilon_{z,1} \sigma T_o^4 \quad (\text{B.25a})$$

$$I_{z,2} = \phi_{z,2} C_2 \varepsilon_{z,2} \sigma T_{z,2}^4 \quad (\text{B.25b})$$

$$I_{z,3} = \phi_{z,3} C_3 \varepsilon_{z,3} \sigma (T_{z,1}^4 + T_{z,2}^4)/2 \quad (\text{B.25c})$$

$$I_{z,4} = 0 \quad (\text{B.25d})$$

where $\phi_{z,i}$ is the configuration factor relative to the upper surface of the flame, for face i of the beam, from annex G of EN 1991-1-2.

B.5.2 Flame emissivity

(1) The emissivity of the flame ε_{zi} for each of the faces 1, 2, 3 and 4 of the beam should be determined from the expression for ε given in annex B of EN 1991-1-2, using a flame thickness λ equal to the dimension λ_i indicated in figure B.7 corresponding to face i of the beam.

B.5.3 Flame absorptivity

(1) The absorptivity of the flame a_z should be determined from:

$$a_z = 1 - e^{-0.3h} \quad (\text{B.26})$$

AC2 where:

h is the height of the opening. See figure B.7b) (height is noted as λ_1). **AC2**

Annex C [informative] Stainless steel

C.1 General

(1) The thermal and mechanical properties of following stainless are given in this annex: 1.4301, 1.4401, 1.4571, 1.4003 and 1.4462.

Note: For other stainless steels according to EN 1993-1-4 the mechanical properties given in 3.2 may be used. The thermal properties may be taken from this annex.

(2) The values of material properties given in this annex should be treated as characteristic.

(3) The mechanical properties of steel at 20 °C should be taken as those given in EN 1993-1-4 for normal temperature design.

C.2 Mechanical properties of steel

C.2.1 Strength and deformation properties

(1) For heating rates between 2 and 50K/min, the strength and deformation properties of stainless steel at elevated temperatures should be obtained from the stress-strain relationship given in figure C.1.

NOTE: For the rules of this standard it is assumed that the heating rates fall within the specified limits.

(2) This relationship should be used to determine the resistances to tension, compression, moment or shear.

(3) Table C.1 gives reduction factors, relative to the appropriate value at 20 °C, for the stress-strain relationship of several stainless steels at elevated temperatures as follows:

- slope of linear elastic range, relative to slope at 20°C:	$k_{E,\theta}$	=	$E_{a,\theta}/E_a$
- proof strength, relative to yield strength at 20°C:	$k_{0.2p,\theta}$	=	$f_{0.2p,\theta}/f_y$
- tensile strength, relative to tensile strength at 20°C:	$k_{u,\theta}$	=	$f_{u,\theta}/f_u$

(4) For the use of simple calculation methods table C.1 gives the correction factor $k_{2\%,\theta}$ for the determination of the yield strength using:

$$f_{y,\theta} = f_{0.2p,\theta} + k_{2\%,\theta} (f_{u,\theta} - f_{0.2p,\theta}) \quad (\text{C.1})$$

(5) For the use of advanced calculation methods table C.2 gives additional values for the stress-strain relationship of several stainless steels at elevated temperatures as follows:

- slope at proof strength, relative to slope at 20°C:	$k_{E_{cl},\theta}$	=	$E_{cl,\theta}/E_a$
- ultimate strain:	$\varepsilon_{u,\theta}$		

C.2.2 Unit mass

(1) The unit mass of steel ρ_a may be considered to be independent of the steel temperature. The following value may be taken:

$$\rho_a = 7850 \text{ kg/m}^3$$

Strain range	Stress σ	Tangent modulus E_t
$\varepsilon \leq \varepsilon_{c,\theta}$	$\frac{E \cdot \varepsilon}{1 + a \cdot \varepsilon^b}$	$\frac{E(1 + a \cdot \varepsilon^b - a \cdot b \cdot \varepsilon^b)}{(1 + a \cdot \varepsilon^b)^2}$
$\varepsilon_{c,\theta} < \varepsilon \leq \varepsilon_{u,\theta}$	$f_{0.2p,\theta} - e + (d/c) \sqrt{c^2 - (\varepsilon_{u,\theta} - \varepsilon)^2}$	$\frac{d \cdot (\varepsilon_{u,\theta} - \varepsilon)}{c \sqrt{c^2 - (\varepsilon_{u,\theta} - \varepsilon)^2}}$ AC2
Parameters	$\varepsilon_{c,\theta} = f_{0.2p,\theta} / E_{a,\theta} + 0.002$	
Functions	$a = \frac{E_{a,\theta} \varepsilon_{c,\theta} - f_{0.2p,\theta}}{f_{0.2p,\theta} \varepsilon_{c,\theta}^b}$ $b = \frac{(1 - \varepsilon_{c,\theta} E_{ct,\theta} / f_{0.2p,\theta}) E_{a,\theta} \varepsilon_{c,\theta}}{(E_{a,\theta} \varepsilon_{c,\theta} / f_{0.2p,\theta} - 1) f_{0.2p,\theta}}$ $c^2 = (\varepsilon_{u,\theta} - \varepsilon_{c,\theta}) \left(\varepsilon_{u,\theta} - \varepsilon_{c,\theta} + \frac{e}{E_{ct,\theta}} \right)$ $d^2 = e (\varepsilon_{u,\theta} - \varepsilon_{c,\theta}) E_{ct,\theta} + e^2$ $e = \frac{(f_{u,\theta} - f_{0.2p,\theta})^2}{(\varepsilon_{u,\theta} - \varepsilon_{c,\theta}) E_{ct,\theta} - 2(f_{u,\theta} - f_{0.2p,\theta})}$	

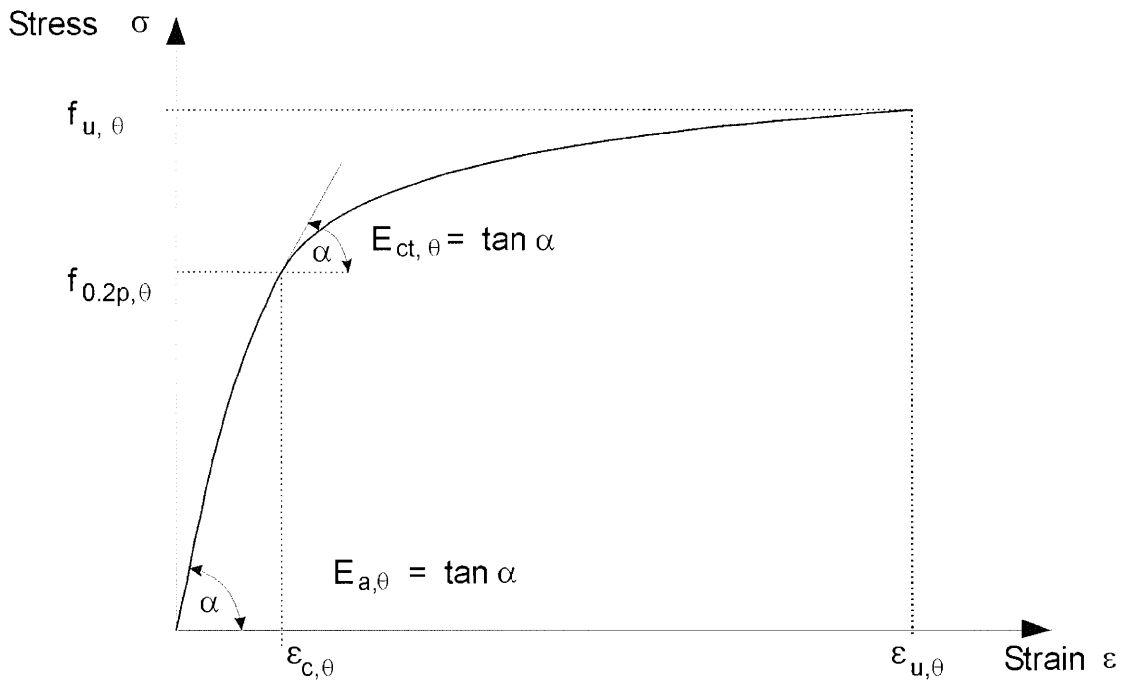

- Key:**
- $f_{u,\theta}$ is tensile strength;
 - $f_{0.2p,\theta}$ is the proof strength at 0.2% plastic strain;
 - $E_{a,\theta}$ is the slope of the linear elastic range;
 - $E_{ct,\theta}$ is the slope at proof strength;
 - $\varepsilon_{c,\theta}$ is the total strain at proof strength;
 - $\varepsilon_{u,\theta}$ is the ultimate strain.

Figure C.1: Stress-strain relationship for stainless steel at elevated temperatures.

Table C.1: Factors for determination of strain and stiffness of stainless steel at elevated temperatures

Steel Temperature θ_a	Reduction factor (relative to E_a) for the slope of the linear elastic range $k_{E,0} = E_{a,0}/E_a$	Reduction factor (relative to f_y) for proof strength $k_{0.2p,0} = f_{0.2p,0}/f_y$	Reduction factor (relative to f_u) for tensile strength $k_{u,0} = f_{u,0}/f_u$	Factor for determination of the yield strength $f_{y,0}$ $k_{2\%,0}$
Grade 1.4301				
20	1,00	1,00	1,00	0,26
100	0,96	0,82	0,87	0,24
200	0,92	0,68	0,77	0,19
300	0,88	0,64	0,73	0,19
400	0,84	0,60	0,72	0,19
500	0,80	0,54	0,67	0,19
600	0,76	0,49	0,58	0,22
700	0,71	0,40	0,43	0,26
800	0,63	0,27	0,27	0,35
900	0,45	0,14	0,15	0,38
1000	0,20	0,06	0,07	0,40
1100	0,10	0,03	0,03	0,40
1200	0,00	0,00	0,00	0,40
Grade 1.4401 / 1.4404				
20	1,00	1,00	1,00	0,24
100	0,96	0,88	0,93	0,24
200	0,92	0,76	0,87	0,24
300	0,88	0,71	0,84	0,24
400	0,84	0,66	0,83	0,21
500	0,80	0,63	0,79	0,20
600	0,76	0,61	0,72	0,19
700	0,71	0,51	0,55	0,24
800	0,63	0,40	0,34	0,35
900	0,45	0,19	0,18	0,38
1000	0,20	0,10	0,09	0,40
1100	0,10	0,05	0,04	0,40
1200	0,00	0,00	0,00	0,40
Grade 1.4571				
20	1,00	1,00	1,00	0,25
100	0,96	0,89	0,88	0,25
200	0,92	0,83	0,81	0,25
300	0,88	0,77	0,80	0,24
400	0,84	0,72	0,80	0,22
500	0,80	0,69	0,77	0,21
600	0,76	0,66	0,71	0,21
700	0,71	0,59	0,57	0,25
800	0,63	0,50	0,38	0,35
900	0,45	0,28	0,22	0,38
1000	0,20	0,15	0,11	0,40
1100	0,10	0,075	0,055	0,40
1200	0,00	0,00	0,00	0,40
Continued				

Table C.1 continued

Steel Temperature θ_a	Reduction factor (relative to E_a) for the slope of the linear elastic range $k_{E,\theta} = E_{a,\theta}/E_a$	Reduction factor (relative to f_y) for proof strength $k_{0,2p,\theta} = f_{0,2p,\theta}/f_y$	Reduction factor (relative to f_u) for tensile strength $k_{u,\theta} = f_{u,\theta}/f_u$	Factor for determination of the yield strength $f_{y,\theta}$ $k_{2\%,\theta}$
Grade 1.4003				
20	1,00	1,00	1,00	0,37
100	0,96	1,00	0,94	0,37
200	0,92	1,00	0,88	0,37
300	0,88	0,98	0,86	0,37
400	0,84	0,91	0,83	0,42
500	0,80	0,80	0,81	0,40
600	0,76	0,45	0,42	0,45
700	0,71	0,19	0,21	0,46
800	0,63	0,13	0,12	0,47
900	0,45	0,10	0,11	0,47
1000	0,20	0,07	0,09	0,47
1100	0,10	0,035	0,045	0,47
1200	0,00	0,00	0,00	0,47
Grade 1.4462				
20	1,00	1,00	1,00	0,35
100	0,96	0,91	0,93	0,35
200	0,92	0,80	0,85	0,32
300	0,88	0,75	0,83	0,30
400	0,84	0,72	0,82	0,28
500	0,80	0,65	0,71	0,30
600	0,76	0,56	0,57	0,33
700	0,71	0,37	0,38	0,40
800	0,63	0,26	0,29	0,41
900	0,45	0,10	0,12	0,45
1000	0,20	0,03	0,04	0,47
1100	0,10	0,015	0,02	0,47
1200	0,00	0,00	0,00	0,47

Table C.2: Reduction factor and ultimate strain for the use of advanced calculation methods

Steel Temperature θ_a	Reduction factor (relative to E_a) for the slope of the linear elastic range $k_{Ect,\theta} = E_{ct,\theta}/E_a$	Ultimate strain $\varepsilon_{u,\theta}$ [-]
Grade 1.4301		
20	0,11	0,40
100	0,05	0,40
200	0,02	0,40
300	0,02	0,40
400	0,02	0,40
500	0,02	0,40
600	0,02	0,35
700	0,02	0,30
800	0,02	0,20
900	0,02	0,20
1000	0,02	0,20
1100	0,02	0,20
1200	0,02	0,20
Grade 1.4401 / 1.4404		
20	0,050	0,40
100	0,049	0,40
200	0,047	0,40
300	0,045	0,40
400	0,030	0,40
500	0,025	0,40
600	0,020	0,40
700	0,020	0,30
800	0,020	0,20
900	0,020	0,20
1000	0,020	0,20
1100	0,020	0,20
1200	0,020	0,20
Grade 1.4571		
20	0,060	0,40
100	0,060	0,40
200	0,050	0,40
300	0,040	0,40
400	0,030	0,40
500	0,025	0,40
600	0,020	0,35
700	0,020	0,30
800	0,020	0,20
900	0,020	0,20
1000	0,020	0,20
1100	0,020	0,20
1200	0,020	0,20
Continued		

Table C.2 continued

Steel Temperature θ_a	Reduction factor (relative to E_a) for the slope of the linear elastic range $k_{Ect,\theta} = E_{ct,\theta}/E_a$	Ultimate strain $\varepsilon_{u,\theta}$ [-]
Grade 1.4003		
20	0,055	0,20
100	0,030	0,20
200	0,030	0,20
300	0,030	0,20
400	0,030	0,15
500	0,030	0,15
600	0,030	0,15
700	0,030	0,15
800	0,030	0,15
900	0,030	0,15
1000	0,030	0,15
1100	0,030	0,15
1200	0,030	0,15
Grade 1.4462		
20	0,100	0,20
100	0,070	0,20
200	0,037	0,20
300	0,035	0,20
400	0,033	0,20
500	0,030	0,20
600	0,030	0,20
700	0,025	0,15
800	0,025	0,15
900	0,025	0,15
1000	0,025	0,15
1100	0,025	0,15
1200	0,025	0,15

C.3 Thermal properties

C.3.1 Thermal elongation

(1) The thermal elongation of austenitic stainless steel Δ/l may be determined from the following:

$$\Delta/l = (16 + 4,79 \times 10^{-3} \theta_a - 1,243 \times 10^{-6} \theta_a^2) \times (\theta_a - 20) 10^{-6} \quad (\text{C.1})$$

where:

- l is the length at 20°C;
- Δ/l is the temperature induced expansion;
- θ_a is the steel temperature [°C].

NOTE: The variation of the thermal elongation with temperature is illustrated in figure C.2.

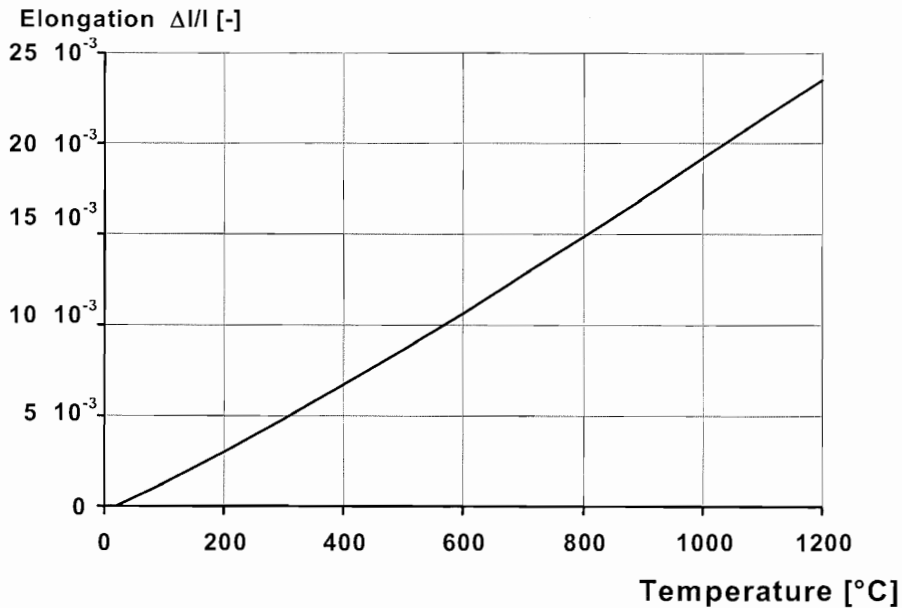

Figure C.2: Thermal elongation of stainless steel as a function of the temperature

C.3.2 Specific heat

(1) The specific heat of stainless steel c_a may be determined from the following:

$$c_a = 450 + 0,280 \times \theta_a - 2,91 \times 10^{-4} \theta_a^2 + 1,34 \times 10^{-7} \theta_a^3 \text{ J/kgK} \quad (\text{C.2})$$

where:

- θ_a is the steel temperature [°C].

NOTE: The variation of the specific heat with temperature is illustrated in figure C.3.

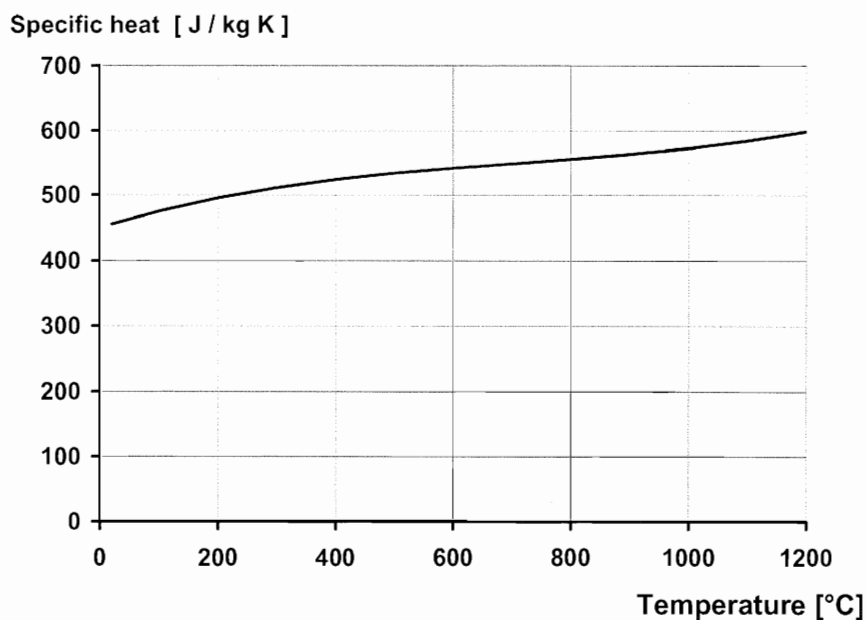

Figure C.3: Specific heat of stainless steel as a function of the temperature

C.3.3 Thermal conductivity

(1) The thermal conductivity of stainless steel λ_a may be determined from the following:

$$\lambda_a = 14,6 + 1,27 \times 10^{-2} \theta_a \text{ W/mK} \quad (\text{C.3})$$

where:

θ_a is the steel temperature [°C].

NOTE: The variation of the thermal conductivity with temperature is illustrated in figure C.4.

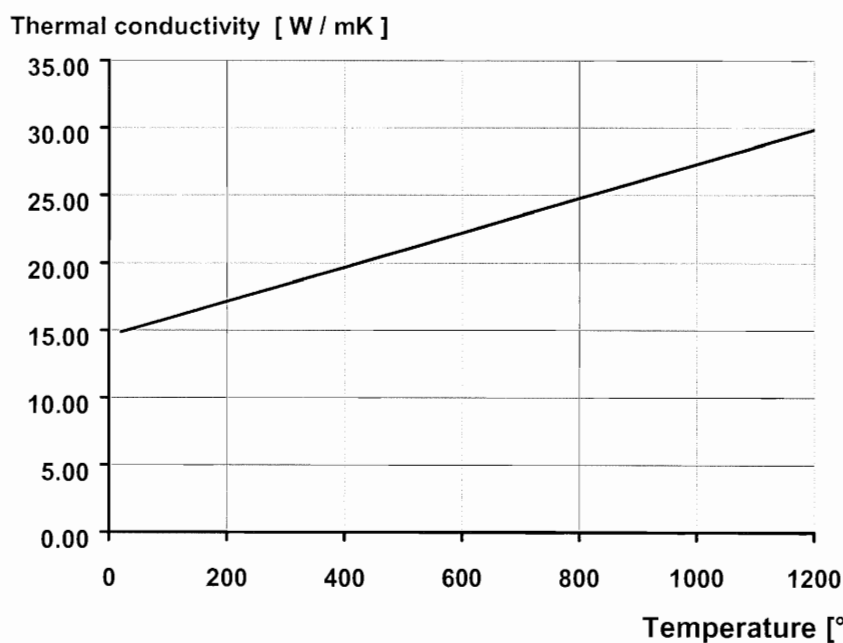

Figure C.4: Thermal conductivity of stainless steel as a function of the temperature

Annex D [informative] Joints

D.1 Bolted joints

(1) Net-section failure at fastener holes need not be considered, provided that there is a fastener in each hole, because the steel temperature is lower at joints due to the presence of additional material.

D1.1 Design Resistance of Bolts in Shear

D1.1.1 Category A: Bearing Type

(1) The fire design resistance of bolts loaded in shear should be determined from:

$$F_{v,t,Rd} = F_{v,Rd} k_{b,\theta} \frac{\gamma_{M2}}{\gamma_{M,fi}} \quad (D.1)$$

where

- $k_{b,\theta}$ $\overline{AC2}$ is the reduction factor determined for the appropriate bolt temperature from Table D.1;
- $F_{v,Rd}$ is the design shear resistance of the bolt per shear plane calculated assuming that the shear plane passes through the threads of the bolt (table 3.4 of EN 1993-1-8);
- γ_{M2} is the partial factor at normal temperature;
- $\gamma_{M,fi}$ is the partial factor for fire conditions.

(2) The design bearing resistance of bolts in fire should be determined from:

$$F_{b,t,Rd} = F_{b,Rd} k_{b,\theta} \frac{\gamma_{M2}}{\gamma_{M,fi}} \quad (D.2)$$

where

- $F_{b,Rd}$ is determined from table 3.4 EN1993-1.8,
- $k_{b,\theta}$ $\overline{AC2}$ is the reduction factor determined for the appropriate bolt temperature from Table D.1

D1.1.2 Category B: Slip resistance at serviceability and category C Slip resistance at ultimate state

(1) Slip resistant joints should be considered as having slipped in fire and the resistance of a single bolt should be determined as for bearing type bolts, see D1.1.1.

D1.2 Design Resistance of Bolts in Tension

D1.2.1 Category D and E: Non-preloaded and preloaded bolts

(1) The design tension resistance of a single bolt in fire should be determined from:

$$F_{ten,t,Rd} = F_{t,Rd} k_{b,\theta} \frac{\gamma_{M2}}{\gamma_{M,fi}} \quad (D.3)$$

where

- $F_{t,Rd}$ is determined from table 3.4 of EN 1993-1-8,
- $k_{b,\theta}$ $\overline{AC2}$ is the reduction factor determined for the appropriate bolt temperature from Table D.1

Table D.1: Strength Reduction Factors for Bolts and Welds

Temperature θ_a	Reduction factor for bolts, $k_{b,\theta}$ (Tension and shear)	Reduction factor for welds, $k_{w,\theta}$
20	1,000	1,000
100	0,968	1,000
150	0,952	1,000
200	0,935	1,000
300	0,903	1,000
400	0,775	0,876
500	0,550	0,627
600	0,220	0,378
700	0,100	0,130
800	0,067	0,074
900	0,033	0,018
1000	0,000	0,000

D.2 Design Resistance of Welds

D2.1 Butt Welds

(1) The design strength of a full penetration butt weld, for temperatures up to 700 °C, should be taken as equal to the strength of the weaker part joined using the appropriate reduction factors for structural steel. For temperatures >700 °C the reduction factors given for fillet welds can also be applied to butt welds.

D2.2 Fillet Welds

(1) The design resistance per unit length of a fillet weld in fire should be determined from :

$$F_{w,t,Rd} = F_{w,Rd} k_{w,\theta} \frac{\gamma_{M2}}{\gamma_{M,jf}} \quad (D.4)$$

where

$k_{w,\theta}$ is obtained from Table D.1 for the appropriate weld temperature;
 $F_{w,Rd}$ is determined from clause 4.5.3. EN 1993-1-8

D.3 Temperature of joints in fire

D3.1 General

- (1) The temperature of a joint may be assessed using the local A/V value of the parts forming that joint.
- (2) As a simplification an uniform distributed temperature may be assessed within the joint; this temperature may be calculated using the maximum value of the ratios A/V of the connected steel members in the vicinity of the joint.
- (3) For beam to column and beam to beam joints, where the beams are supporting any type of concrete floor, the temperature for the joint may be obtained from the temperature of the bottom flange at mid span.
- (4) In applying the method in 4.2.5 the temperature of the joint components may be determined as follows:
 - a) If the depth of the beam is less or equal than 400mm

$$\theta_h = 0,88\theta_o [1 - 0,3(h/D)] \quad (D.5)$$

where

- θ_h is the temperature at height h (mm) of the steel beam (Figure D.1);
- θ_o is the bottom flange temperature of the steel beam remote from the joint;
- h is the height of the component being considered above the bottom of the beam in (mm);
- D is the depth of the beam in (mm).

- b) If the depth of the beam is greater than 400mm

- i) When h is less or equal than D/2

$$\theta_h = 0,88\theta_o \quad (D.6)$$

- ii) When h is greater than D/2

$$\theta_h = 0,88\theta_o [1 + 0,2 (1 - 2h/D)] \quad (D.7)$$

where

- θ_o is the bottom flange temperature of the steel beam remote from the joint;
- h is the height of the component being considered above the bottom of the beam in (mm);
- D is the depth of the beam in (mm).

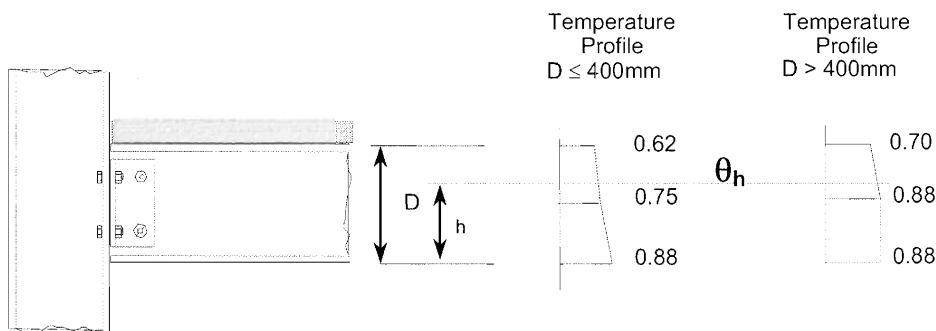

Figure D.1 Thermal gradient within the depth of a composite joint

Annex E [informative] Class 4 cross-sections

E.1 Advanced calculation models

(1) Advanced calculation models may be used for the design of class 4 sections when all stability effects are taken into account.

E.2 Simple calculation models

(1) The resistance of members with a class 4 cross section should be verified with the equations given in 4.2.3.2 for compression members, in 4.2.3.4 for beams in bending, and in 4.2.3.5 for members subject to bending and axial compression, in which the area is replaced by the effective area and the section modulus is replaced by the effective section modulus.

(2) The effective cross section area and the effective section modulus should be determined in accordance with EN 1993-1-3 and EN 1993-1-5, i.e. based on the material properties at 20°C.

(3) For the design under fire conditions the design yield strength of steel should be taken as the 0,2 percent proof strength. This design yield strength may be used to determine the resistance to tension, compression, moment or shear.

(4) Reduction factors for the design yield strength of carbon steels relative to the yield strength at 20°C may be taken from table E.1:

- design yield strength, relative to yield strength at 20°C: $k_{p0,2,\theta} = f_{p0,2,\theta}/f_y$
- slope of linear elastic range, relative to slope at 20°C: $k_{E,\theta} = E_{a,\theta}/E_a$

NOTE: These reduction factors are illustrated in figure E.1.

(5) Reduction factors $\overline{\alpha}_{AC2}$ for the design proof strength of stainless steels relative to the proof strength $\overline{\alpha}_{AC2}$ at 20°C may be taken from annex C.

Table E.1: Reduction factors for carbon steel for the design of class 4 sections at elevated temperatures

Steel Temperature θ_a	Reduction factor (relative to f_y) for the design yield strength of hot rolled and welded class 4 sections $k_{AC2,0.2,p,\theta} = f_{p0.2,\theta}/f_y$	Reduction factor (relative to f_{yb}) for the design yield strength of cold formed class 4 sections $k_{p0.2,\theta} = f_{p0.2,\theta}/f_{yb}$
20°C	1,00	
100°C	1,00	
200°C	0,89	
300°C	0,78	
400°C	0,65	
500°C	0,53	
600°C	0,30	
700°C	0,13	
800°C	0,07	
900°C	0,05	
1000°C	0,03	
1100°C	0,02	
1200°C	0,00	
<p>NOTE 1: For intermediate values of the steel temperature, linear interpolation may be used.</p> <p>NOTE 2: The definition for f_{yb} should be taken from EN 1993-1-3</p>		

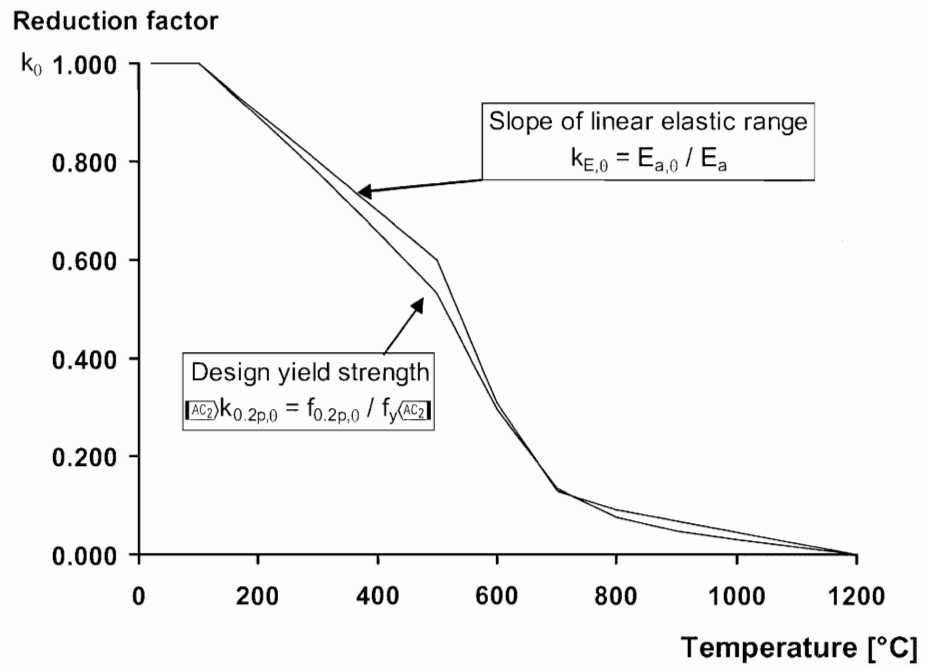

Figure E.2: Reduction factors for the stress-strain relationship of cold formed and hot rolled class 4 steel sections at elevated temperatures

