

The European Union

EDICT OF GOVERNMENT

In order to promote public education and public safety, equal justice for all, a better informed citizenry, the rule of law, world trade and world peace, this legal document is hereby made available on a noncommercial basis, as it is the right of all humans to know and speak the laws that govern them.

EN 1991-1-5 (2003) (English): Eurocode 1: Actions on structures - Part 1-5: General actions - Thermal actions
[Authority: The European Union Per Regulation 305/2011, Directive 98/34/EC, Directive 2004/18/EC]



BLANK PAGE



English version

Eurocode 1: Actions on structures - Part 1-5: General actions - Thermal actions

Eurocode 1: Action sur les structures - Partie 1-5: Actions
générales - Actions thermiques

This European Standard was approved by CEN on 18 September 2003.

CEN members are bound to comply with the CEN/CENELEC Internal Regulations which stipulate the conditions for giving this European Standard the status of a national standard without any alteration. Up-to-date lists and bibliographical references concerning such national standards may be obtained on application to the Management Centre or to any CEN member.

This European Standard exists in three official versions (English, French, German). A version in any other language made by translation under the responsibility of a CEN member into its own language and notified to the Management Centre has the same status as the official versions.

CEN members are the national standards bodies of Austria, Belgium, Czech Republic, Denmark, Finland, France, Germany, Greece, Hungary, Iceland, Ireland, Italy, Luxembourg, Malta, Netherlands, Norway, Portugal, Slovakia, Spain, Sweden, Switzerland and United Kingdom.



EUROPEAN COMMITTEE FOR STANDARDIZATION
COMITÉ EUROPÉEN DE NORMALISATION
EUROPÄISCHES KOMITEE FÜR NORMUNG

Management Centre: rue de Stassart, 36 B-1050 Brussels

CONTENTS	Page
FOREWORD	4
BACKGROUND TO THE EUROCODE PROGRAMME	4
STATUS AND FIELD OF APPLICATION OF EUROCODES	5
NATIONAL STANDARDS IMPLEMENTING EUROCODES	6
LINKS BETWEEN EUROCODES AND PRODUCT HARMONIZED TECHNICAL SPECIFICATIONS (ENs AND ETAs).....	6
ADDITIONAL INFORMATION SPECIFIC TO EN 1991-1-5.....	6
NATIONAL ANNEX FOR EN 1991-1-5.....	7
SECTION 1 GENERAL	8
1.1 SCOPE	8
1.2 NORMATIVE REFERENCES	8
1.3 ASSUMPTIONS	8
1.4 DISTINCTION BETWEEN PRINCIPLES AND APPLICATION RULES	9
1.5 DEFINITIONS	9
1.6 SYMBOLS	10
SECTION 2 CLASSIFICATION OF ACTIONS	13
SECTION 3 DESIGN SITUATIONS	14
SECTION 4 REPRESENTATION OF ACTIONS	15
SECTION 5 TEMPERATURE CHANGES IN BUILDINGS	17
5.1 GENERAL	17
5.2 DETERMINATION OF TEMPERATURES.....	17
5.3 DETERMINATION OF TEMPERATURE PROFILES.....	18
SECTION 6 TEMPERATURE CHANGES IN BRIDGES	20
6.1 BRIDGE DECKS.....	20
6.1.1 <i>Bridge deck types</i>	20
6.1.2 <i>Consideration of thermal actions</i>	20
6.1.3 <i>Uniform temperature component</i>	20
6.1.4 <i>Temperature difference components</i>	24
6.1.5 <i>Simultaneity of uniform and temperature difference components</i>	30
6.1.6 <i>Differences in the uniform temperature component between different structural elements</i>	31
6.2 BRIDGE PIERS	31
6.2.1 <i>Consideration of thermal actions</i>	31
6.2.2 <i>Temperature differences</i>	31
SECTION 7 TEMPERATURE CHANGES IN INDUSTRIAL CHIMNEYS, PIPELINES, SILOS, TANKS AND COOLING TOWERS	32
7.1 GENERAL	32
7.2 TEMPERATURE COMPONENTS.....	32
7.2.1 <i>Shade air temperature</i>	32
7.2.2 <i>Flue gas, heated liquids and heated materials temperature</i>	33

7.2.3	<i>Element temperature</i>	33
7.3	CONSIDERATION OF TEMPERATURE COMPONENTS	33
7.4	DETERMINATION OF TEMPERATURE COMPONENTS.....	33
7.5	VALUES OF TEMPERATURE COMPONENTS (INDICATIVE VALUES).....	34
7.6	SIMULTANEITY OF TEMPERATURE COMPONENTS.....	34
ANNEX A (NORMATIVE) ISOTHERMS OF NATIONAL MINIMUM AND MAXIMUM SHADE AIR TEMPERATURES		36
A.1	GENERAL	36
A.2	MAXIMUM AND MINIMUM SHADE AIR TEMPERATURE VALUES WITH AN ANNUAL PROBABILITY OF BEING EXCEEDED P OTHER THAN 0,02.....	36
ANNEX B (NORMATIVE) TEMPERATURE DIFFERENCES FOR VARIOUS SURFACING DEPTHS.....		39
ANNEX C (INFORMATIVE) COEFFICIENTS OF LINEAR EXPANSION		42
ANNEX D (INFORMATIVE) TEMPERATURE PROFILES IN BUILDINGS AND OTHER CONSTRUCTION WORKS		44
BIBLIOGRAPHY		46

BS EN 1991-1-5: 2003

EN 1991-1-5: 2003 (E)

Foreword

This document (EN 1991-1-5) has been prepared by Technical Committee CEN/TC250 "Structural Eurocodes", the secretariat of which is held by BSI.

This European Standard shall be given the status of a national standard, either by publication of an identical text or by endorsement, at the latest by May 2004, and conflicting national standards shall be withdrawn at the latest by March 2010.

Annexes A and B are normative. Annexes C and D are informative.

This document supersedes ENV 1991-2-5:1997.

According to the CEN/CENELEC Internal Regulations, the national standards organizations of the following countries are bound to implement this European Standard: Austria, Belgium, Czech Republic, Denmark, Finland, France, Germany, Greece, Hungary, Iceland, Ireland, Italy, Luxembourg, Malta, Netherlands, Norway, Portugal, Slovakia, Spain, Sweden, Switzerland and the United Kingdom.

Background to the Eurocode Programme

In 1975, the Commission of the European Communities decided on an action programme in the field of construction, based on article 95 of the treaty. The objective of the programme was the elimination of technical obstacles to trade and the harmonization of technical specifications.

Within this action programme, the Commission took the initiative to establish a set of harmonised technical rules for the design of construction works which, in a first stage, would serve as an alternative to the national rules in force in the Member States and, ultimately, would replace them.

For fifteen years, the Commission, with the help of a Steering Committee with Representatives of Member States, conducted the development of the Eurocodes programme, which led to the first generation of European codes in the 1980's.

In 1989, the Commission and the Member States of the EU and EFTA decided, on the basis of an agreement between the Commission and CEN, to transfer the preparation and the publication of the Eurocodes to CEN through a series of mandates, in order to provide them with a future status of European Standard (EN). This links *de facto* the Eurocode with the provisions of all the Council's Directives and/or Commission's Decisions dealing with European Standards (e.g. the Council Directive 89/106/EEC on construction products - CPD - and Council Directives 93/37/EEC, 92/50/EEC and 89/440/EEC on public works and services and equivalent EFTA Directives initiated in pursuit of settings up the internal market).

The Structural Eurocode programme comprises the following standards generally consisting of a number of Parts:

EN 1990	Eurocode: Basis of Structural Design
EN 1991	Eurocode 1: Actions on structures
EN 1992	Eurocode 2: Design of concrete structures
EN 1993	Eurocode 3: Design of steel structures
EN 1994	Eurocode 4: Design of composite steel and concrete structures
EN 1995	Eurocode 5: Design of timber structures
EN 1996	Eurocode 6: Design of masonry structures
EN 1997	Eurocode 7: Geotechnical design
EN 1998	Eurocode 8: Design of structures for earthquake resistance
EN 1999	Eurocode 9: Design of aluminium alloy structures

Eurocode standards recognize the responsibility of regulatory authorities in each Member State and have safeguarded their right to determine values related to regulatory safety matters at national level where these continue to vary from State to State.

Status and field of application of Eurocodes

The Member States of the EU and EFTA recognize that Eurocodes serve as reference documents for the following purposes:

- as a means of providing compliance of building and civil engineering works with the essential requirements of Council Directive 89/106/EEC, particularly Essential Requirement N°1 - Mechanical resistance and stability - and Essential Requirement N°2 - Safety in case of fire;
- as a basis for specifying contracts for construction works and related engineering services;
- as a framework for drawing up harmonized technical specifications for construction products (ENs and ETAs)

The Eurocodes, as far as they concern the construction works themselves, have a direct relationship with the Interpretative Documents referred to in Article 12 of the CPD, although they are of a different nature from harmonized product standards. Therefore, technical aspects arising from the Eurocodes work need to be adequately considered by CEN Technical Committees and/or EOTA Working Groups working on product standards with a view to achieving a full compatibility of these technical specifications with the Eurocodes.

The Eurocode standards provide common structural design rules for everyday use for the design of whole structures and component products of both a traditional and an innovative nature. Unusual forms of construction design conditions are not specifically covered and additional expert consideration will be required by the designer in such cases.

BS EN 1991-1-5: 2003

EN 1991-1-5: 2003 (E)

National Standards implementing Eurocodes

The National Standards implementing Eurocodes will comprise the full text of the Eurocode (including any annexes), as published by CEN, which may be preceded by a National title page and National foreword, and may be followed by a National annex (informative).

The National annex (informative) may only contain information on those parameters which are left open in the Eurocode for national choice, known as Nationally Determined parameters, to be used for the design of buildings and civil engineering works to be constructed in the country concerned, i.e.:

- values and/or classes where alternatives are given in the Eurocode,
- values to be used where a symbol only is given in the Eurocode,
- country specific data (geographical, climatic, etc.), e.g. snow map,
- the procedure to be used where alternative procedures are given in the EN Eurocode.

It may also contain

- decisions on the application of informative annexes,
- references to non-contradictory complementary information to assist the user to apply the Eurocode.

Links between Eurocodes and product harmonized technical specifications (ENs and ETAs)

There is a need for consistency between the harmonized technical specifications for construction products and the technical rules for works. Furthermore, all the information accompanying the CE Marking of the construction products which refer to Eurocodes should clearly mention which Nationally Determined Parameters have been taken into account.

Additional information specific to EN 1991-1-5

EN 1991-1-5 gives design guidance for thermal actions arising from climatic and operational conditions on buildings and civil engineering works.

Information on thermal actions induced by fire is given in EN 1991-1-2.

EN 1991-1-5 is intended for clients, designers, contractors and relevant authorities.

EN 1991-1-5 is intended to be used with EN 1990, the other Parts of EN 1991 and EN 1992-1999 for the design of structures.

In the case of bridges, the National annexes specify whether the general non-linear or the simplified linear temperature components should be used in design calculations.

In the case of chimneys, references should be made to EN 13084-1 for thermal actions from operating processes.

National annex for EN 1991-1-5

This standard gives alternative procedures, values and recommendations for classes with notes indicating where national choices may have to be made. Therefore the National Standard implementing EN 1991-1-5 should have a National annex containing all Nationally Determined Parameters to be used for the design of buildings and civil engineering works to be constructed in the relevant country.

National choice is allowed in EN 1991-1-5 through clauses:

- 5.3(2) (Tables 5.1, 5.2 and 5.3)
- 6.1.1 (1)
- 6.1.2(2)
- 6.1.3.1(4)
- AC1 - 6.1.3.2(1)P AC1
- 6.1.3.3(3)
- 6.1.4(3)
- 6.1.4.1(1)
- 6.1.4.2(1)
- 6.1.4.3(1)
- 6.1.4.4(1)
- 6.1.5(1)
- 6.1.6(1)
- 6.2.1(1)P
- 6.2.2(1)
- 6.2.2(2)
- AC1 - 7.2.1(1)P AC1
- 7.5(3)
- 7.5(4)
- A.1(1)
- A.1(3)
- A.2(2)
- B(1) (Tables B.1, B.2 and B.3)

Section 1 General

1.1 Scope

(1) EN 1991-1-5 gives principles and rules for calculating thermal actions on buildings, bridges and other structures including their structural elements. Principles needed for cladding and other appendages of buildings are also provided.

(2) This Part describes the changes in the temperature of structural elements. Characteristic values of thermal actions are presented for use in the design of structures which are exposed to daily and seasonal climatic changes. Structures not so exposed may not need to be considered for thermal actions.

(3) Structures in which thermal actions are mainly a function of their use (e.g. cooling towers, silos, tanks, warm and cold storage facilities, hot and cold services etc) are treated in Section 7. Chimneys are treated in EN 13084-1.

1.2 Normative references

This European Standard incorporates, by dated or undated reference, provisions from other publications. These normative references are cited at the appropriate places in the text and the publications are listed hereafter. For dated references, subsequent amendments to or revisions of any of these publications apply to this European Standard only when incorporated in it by amendment or revision. For undated references the latest edition of the publication referred to applies (including amendments).

EN 1990:2002	Eurocode: Basis of structural design
prEN 1991-1-6	Eurocode 1: Actions on structures Part 1.6: General actions - Actions during execution
EN 13084-1	Free-standing industrial chimneys Part 1: General requirements
ISO 2394	General principles on reliability for structures
ISO 3898	Bases of design of structures - Notations. General symbols
ISO 8930	General principles on reliability for structures. List of equivalent terms

1.3 Assumptions

(1)P The general assumptions of EN 1990 also apply to this Part.

1.4 Distinction between principles and application rules

(1)P The rules in EN 1990:2002, 1.4 also apply to this Part.

1.5 Terms and definitions

For the purposes of this European Standard, the definitions given in EN 1990, ISO 2394, ISO 3898 and ISO 8930 and the following apply.

1.5.1

thermal actions

thermal actions on a structure or a structural element are those actions that arise from the changes of temperature fields within a specified time interval

1.5.2

shade air temperature

the shade air temperature is the temperature measured by thermometers placed in a white painted louvred wooden box known as a "Stevenson screen"

1.5.3

maximum shade air temperature T_{\max}

value of maximum shade air temperature with an annual probability of being exceeded of 0,02 (equivalent to a mean return period of 50 years), based on the maximum hourly values recorded

1.5.4

minimum shade air temperature T_{\min}

value of minimum shade air temperature with an annual probability of being exceeded of 0,02 (equivalent to a mean return period of 50 years), based on the minimum hourly values recorded

1.5.5

initial temperature T_0

the temperature of a structural element at the relevant stage of its restraint (completion)

1.5.6

cladding

the part of the building which provides a weatherproof membrane. Generally cladding will only carry self weight and/or wind actions

1.5.7

uniform temperature component

the temperature, constant over the cross section, which governs the expansion or contraction of an element or structure (for bridges this is often defined as the "effective" temperature, but the term "uniform" has been adopted in this part)

1.5.8

temperature difference component

the part of a temperature profile in a structural element representing the temperature difference between the outer face of the element and any in-depth point

1.6 Symbols

(1) For the purposes of this Part of Eurocode 1, the following symbols apply.

NOTE: The notation used is based on ISO 3898

(2) A basic list of notations is provided in EN 1990, and the additional notations below are specific to this Part.

Latin upper case letters

R	thermal resistance of structural element
R_{in}	thermal resistance at the inner surface
R_{out}	thermal resistance at the outer surface
T_{max}	maximum shade air temperature with an annual probability of being exceeded of 0,02 (equivalent to a mean return period of 50 years)
T_{min}	minimum shade air temperature with an annual probability of being exceeded of 0,02 (equivalent to a mean return period of 50 years)
$T_{max,p}$	maximum shade air temperature with an annual probability of being exceeded p (equivalent to a mean return period of $1/p$)
$T_{min,p}$	minimum shade air temperature with an annual probability of being exceeded p (equivalent to a mean return period of $1/p$)
$T_{e,max}$	maximum uniform bridge temperature component
$T_{e,min}$	minimum uniform bridge temperature component
T_0	initial temperature when structural element is restrained
T_{in}	air temperature of the inner environment
T_{out}	temperature of the outer environment
$\Delta T_1, \Delta T_2,$ $\Delta T_3, \Delta T_4$	values of heating (cooling) temperature differences

ΔT_U	uniform temperature component
$\Delta T_{N, \text{exp}}$	maximum expansion range of uniform bridge temperature component ($T_{e.\text{max}} \geq T_0$)
$\Delta T_{N, \text{con}}$	maximum contraction range of uniform bridge temperature component ($T_0 \geq T_{e.\text{min}}$)
ΔT_N	overall range of uniform bridge temperature component
ΔT_M	linear temperature difference component
$\Delta T_{M,\text{heat}}$	linear temperature difference component (heating)
$\Delta T_{M,\text{cool}}$	linear temperature difference component (cooling)
ΔT_E	non-linear part of the temperature difference component
ΔT	sum of linear temperature difference component and non-linear part of the temperature difference component
ΔT_p	temperature difference between different parts of a structure given by the difference of average temperatures of these parts

Latin lower case letters

h	height of the cross-section
k_1, k_2 k_3, k_4	coefficients for calculation of maximum (minimum) shade air temperature with an annual probability of being exceeded, p , other than 0,02
k_{sur}	surfacing factor for linear temperature difference component
p	annual probability of maximum (minimum) shade air temperature being exceeded (equivalent to a mean return period of $1/p$ years)
u, c	mode and scale parameter of annual maximum (minimum) shade air temperature distribution

Greek lower case letters

α_T	coefficient of linear expansion ($1/^\circ\text{C}$)
λ	thermal conductivity

BS EN 1991-1-5: 2003

EN 1991-1-5: 2003 (E)

ω_N reduction factor of uniform temperature component for combination with temperature difference component

ω_M reduction factor of temperature difference component for combination with uniform temperature component

Section 2 Classification of actions

(1)P Thermal actions shall be classified as variable and indirect actions, see EN 1990:2002, 1.5.3 and 4.1.1.

(2) All values of thermal actions given in this Part are characteristic values unless it is stated otherwise.

(3) Characteristic values of thermal actions as given in this Part are values with an annual probability of being exceeded of 0,02, unless otherwise stated, e.g. for transient design situations.

NOTE: For transient design situations, the related values of thermal actions may be derived using the calculation method given in A.2.

Section 3 Design situations

(1)P Thermal actions shall be determined for each relevant design situation identified in accordance with EN 1990.

NOTE: Structures not exposed to daily and seasonal climatic and operational temperature changes may not need to be considered for thermal actions.

(2)P The elements of loadbearing structures shall be checked to ensure that thermal movement will not cause overstressing of the structure, either by the provision of movement joints or by including the effects in the design.

Section 4 Representation of actions

(1) Daily and seasonal changes in shade air temperature, solar radiation, re-radiation, etc., will result in variations of the temperature distribution within individual elements of a structure.

(2) The magnitude of the thermal effects will be dependent on local climatic conditions, together with the orientation of the structure, its overall mass, finishes (e.g. cladding in buildings), and in the case of building structures, heating and ventilation regimes and thermal insulation.

(3) The temperature distribution within an individual structural element may be split into the following four essential constituent components, as illustrated in Figure 4.1:

- A uniform temperature component, ΔT_u ;
- A linearly varying temperature difference component about the z-z axis, ΔT_{My} ;
- A linearly varying temperature difference component about the y-y axis, ΔT_{Mz} ;
- A non-linear temperature difference component, ΔT_E . This results in a system of self-equilibrated stresses which produce no net load effect on the element.

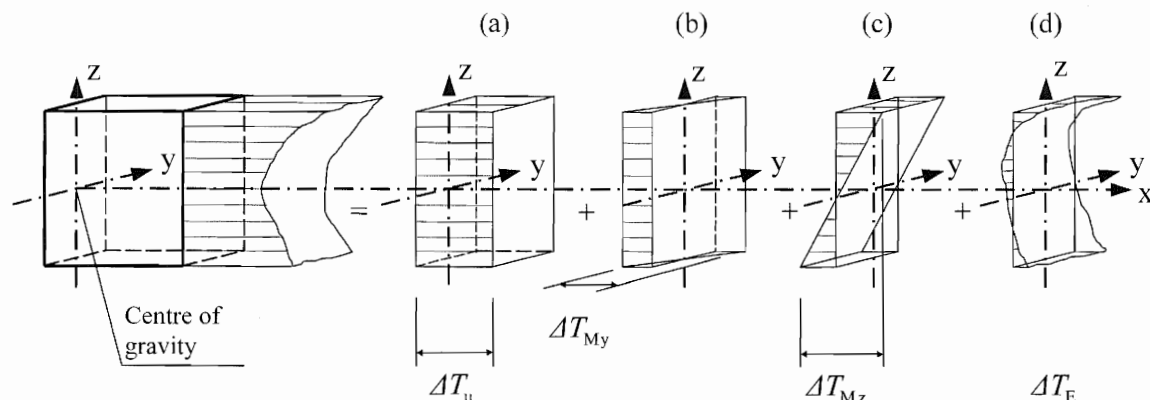

Figure 4.1: Diagrammatic representation of constituent components of a temperature profile

(4) The strains and therefore any resulting stresses, are dependent on the geometry and boundary conditions of the element being considered and on the physical properties of the material used. When materials with different coefficients of linear expansion are used compositely the thermal effect should be taken into account.

(5) For the purpose of deriving thermal effects, the coefficient of linear expansion for a material should be used.

BS EN 1991-1-5: 2003

EN 1991-1-5: 2003 (E)

NOTE: The coefficient of linear expansion for a selection of commonly used materials is given in annex C.

Section 5 Temperature changes in buildings

5.1 General

(1)P Thermal actions on buildings due to climatic and operational temperature changes shall be considered in the design of buildings where there is a possibility of the ultimate or serviceability limit states being exceeded due to thermal movement and/or stresses.

NOTE 1: Volume changes and/or stresses due to temperature changes may also be influenced by:

- a) shading of adjacent buildings,
- b) use of different materials with different thermal expansion coefficients and heat transfer,
- c) use of different shapes of cross-section with different uniform temperature.

NOTE 2: Moisture and other environmental factors may also affect the volume changes of elements.

5.2 Determination of temperatures

(1) Thermal actions on buildings due to climatic and operational temperature changes should be determined in accordance with the principles and rules provided in this Section taking into account national (regional) data and experience.

(2)P The climatic effects shall be determined by considering the variation of shade air temperature and solar radiation. Operational effects (due to heating, technological or industrial processes) shall be considered in accordance with the particular project.

(3)P In accordance with the temperature components given in Section 4, climatic and operational thermal actions on a structural element shall be specified using the following basic quantities:

- a) A uniform temperature component ΔT_u given by the difference between the average temperature T of an element and its initial temperature T_0 .
- b) A linearly varying temperature component given by the difference ΔT_M between the temperatures on the outer and inner surfaces of a cross section, or on the surfaces of individual layers.
- c) A temperature difference ΔT_p of different parts of a structure given by the difference of average temperatures of these parts.

NOTE: Values of ΔT_M and ΔT_p may be provided for the particular project.

(4) In addition to ΔT_u , ΔT_M and ΔT_p , local effects of thermal actions should be considered where relevant (e.g. at supports or fixings of structural and cladding

elements). Adequate representation of thermal actions should be defined taking into account the location of the building and structural detailing.

(5) The uniform temperature component of a structural element ΔT_u is defined as:

$$\Delta T_u = T - T_0 \quad (5.1)$$

where:

T is an average temperature of a structural element due to climatic temperatures in winter or summer season and due to operational temperatures.

(6) The quantities ΔT_u , ΔT_M , ΔT_p , and T should be determined in accordance with the principles provided in 5.3 using regional data. When regional data are not available, the rules in 5.3 may be applied.

5.3 Determination of temperature profiles

(1) The temperature T in Expression (5.1) should be determined as the average temperature of a structural element in winter or summer using a temperature profile. In the case of a sandwich element T is the average temperature of a particular layer.

NOTE 1: Methods of the thermal transmission theory are indicated in annex D.

NOTE 2: When elements of one layer are considered and when the environmental conditions on both sides are similar, T may be approximately determined as the average of inner and outer environment temperature T_{in} and T_{out} .

(2) The temperature of the inner environment, T_{in} , should be determined in accordance with Table 5.1. The temperature of the outer environment, T_{out} , should be determined in accordance with:

- a) Table 5.2 for parts located above ground level,
- b) Table 5.3 for underground parts.

NOTE: The temperatures T_{out} for the summer season as indicated in Table 5.2 are dependent on the surface absorptivity and its orientation:

- the maximum is usually reached for surfaces facing the west, south-west or for horizontal surfaces,
- the minimum (in °C about half of the maximum) for surfaces facing the north.

Table 5.1: Indicative temperatures of inner environment T_{in}

Season	Temperature T_{in}
Summer	T_1
Winter	T_2

NOTE: Values for T_1 and T_2 may be specified in the National Annex. When no data are available the values $T_1 = 20\text{ °C}$ and $T_2 = 25\text{ °C}$ are recommended.

Table 5.2: Indicative temperatures T_{out} for buildings above the ground level

Season	Significant factor	Temperature T_{out} in $^{\circ}\text{C}$
Summer	Relative absorptivity depending on surface colour	$T_{max} + T_3$
	0,5 bright light surface	$T_{max} + T_4$
	0,7 light coloured surface	$T_{max} + T_5$
	0,9 dark surface	
Winter		T_{min}

NOTE: Values of the maximum shade air temperature T_{max} , minimum shade air shade temperature T_{min} , and solar radiation effects T_3 , T_4 , and T_5 may be specified in the National Annex. If no data are available for regions between latitudes 45°N and 55°N the values $T_3 = 0^{\circ}\text{C}$, $T_4 = 2^{\circ}\text{C}$, and $T_5 = 4^{\circ}\text{C}$ are recommended, , for North-East facing elements and $T_3 = 18^{\circ}\text{C}$, $T_4 = 30^{\circ}\text{C}$, and $T_5 = 42^{\circ}\text{C}$ for South-West or horizontal facing elements.

Table 5.3: Indicative temperatures T_{out} for underground parts of buildings

Season	Depth below the ground level	Temperature T_{out} in $^{\circ}\text{C}$
Summer	Less than 1 m	T_6
	More than 1 m	T_7
Winter	Less than 1 m	T_8
	More than 1 m	T_9

NOTE: Values T_6 , T_7 , T_8 , and T_9 may be specified in the National Annex. If no data are available for regions between latitudes 45°N and 55°N the values $T_6 = 8^{\circ}\text{C}$, $T_7 = 5^{\circ}\text{C}$, $T_8 = -5^{\circ}\text{C}$ and $T_9 = -3^{\circ}\text{C}$ are recommended.

Section 6 Temperature changes in bridges

6.1 Bridge decks

6.1.1 Bridge deck types

(1) For the purposes of this Part, bridge decks are grouped as follows:

Type 1	Steel deck:	- steel box girder - steel truss or plate girder
Type 2	Composite deck	
Type 3	Concrete deck:	- concrete slab - concrete beam - concrete box girder

NOTE 1: See also Figure 6.2.

NOTE 2: The National Annex may specify values of the uniform temperature component and the temperature difference component for other types of bridges.

6.1.2 Consideration of thermal actions

(1) Representative values of thermal actions should be assessed by the uniform temperature component (see 6.1.3) and the temperature difference components (see 6.1.4).

(2) The vertical temperature difference component given in 6.1.4 should generally include the non-linear component, see 4(3). Either Approach 1 (see 6.1.4.1) or Approach 2 (see 6.1.4.2) should be used.

NOTE: The selection of the approach to be used in a Country may be found in its National Annex.

(3) Where a horizontal temperature difference needs to be considered a linear temperature difference component may be assumed in the absence of other information (see 6.1.4.3).

6.1.3 Uniform temperature component

6.1.3.1 General

(1) The uniform temperature component depends on the minimum and maximum temperature which a bridge will achieve. This results in a range of uniform

temperature changes which, in an unrestrained structure would result in a change in element length.

(2) The following effects should be taken into account where relevant:

- Restraint of associated expansion or contraction due to the type of construction (e.g. portal frame, arch, elastomeric bearings);
- Friction at roller or sliding bearings;
- Non-linear geometric effects (2nd order effects);
- For railway bridges the interaction effects between the track and the bridge due to the variation of the temperature of the deck and of the rails may induce supplementary horizontal forces in the bearings (and supplementary forces in the rails).

NOTE: For more information, see EN 1991-2.

(3)P Minimum shade air temperature (T_{\min}) and maximum shade air temperature (T_{\max}) for the site shall be derived from isotherms in accordance with 6.1.3.2.

(4) The minimum and maximum uniform bridge temperature components $T_{e,\min}$ and $T_{e,\max}$ should be determined.

NOTE: The National Annex may specify $T_{e,\min}$ and $T_{e,\max}$. Figure 6.1 below gives recommended values.

AC1

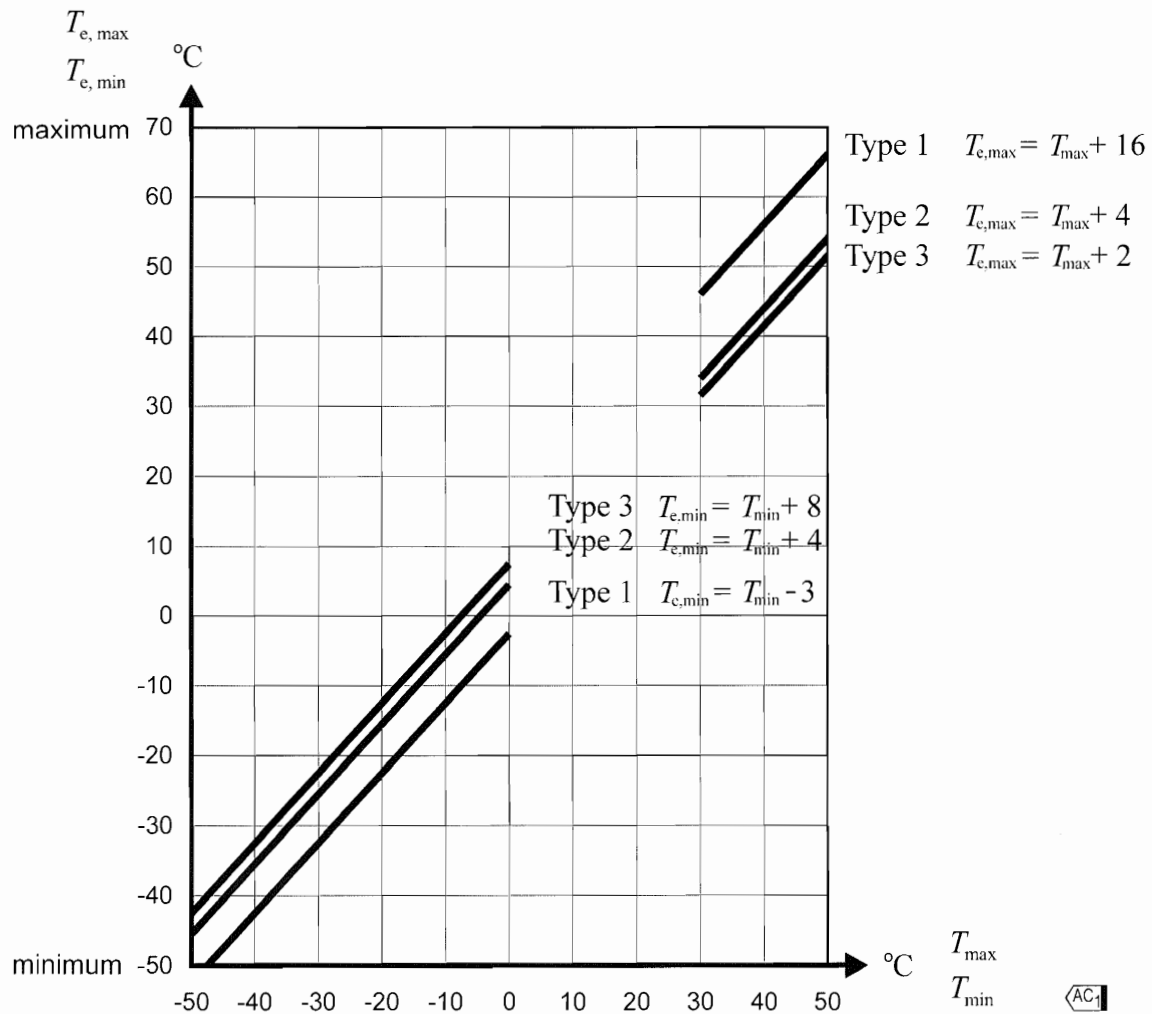

NOTE 1: The values in Figure 6.1 are based on daily temperature ranges of 10°C . Such a range may be considered appropriate for most Member States.

NOTE 2: For steel truss and plate girders the maximum values given for type 1 may be reduced by 3°C .

Figure 6.1: Correlation between minimum/maximum shade air temperature (T_{\min}/T_{\max}) and minimum/maximum uniform bridge temperature component ($T_{e,\min}/T_{e,\max}$)

6.1.3.2 Shade air temperature

(1)P Characteristic values of minimum and maximum shade air temperatures for the site location shall be obtained, e.g. from national maps of isotherms.

NOTE: Information (e.g. maps of isotherms) on minimum and maximum shade air temperatures to be used in a Country may be found in its National Annex.

(2) These characteristic values should represent shade air temperatures for mean sea level in open country with an annual probability of being exceeded of 0,02. For other annual probabilities of being exceeded (p other than 0,02), height above sea level and local conditions (e.g. frost pockets) the values should be adjusted in accordance with annex A.

(3) Where an annual probability of being exceeded of 0,02 is deemed inappropriate, the minimum shade air temperatures and the maximum shade air temperatures should be modified in accordance with annex A.

6.1.3.3 Range of uniform bridge temperature component

(1)P The values of minimum and maximum uniform bridge temperature components for restraining forces shall be derived from the minimum (T_{\min}) and maximum (T_{\max}) shade air temperatures (see 6.1.3.1(3) and 6.1.3.1(4)).

(2) The initial bridge temperature T_0 at the time that the structure is restrained may be taken from annex A for calculating contraction down to the minimum uniform bridge temperature component and expansion up to the maximum uniform bridge temperature component.

(3) Thus the characteristic value of the maximum contraction range of the uniform bridge temperature component, $\Delta T_{N,\text{con}}$ should be taken as

$$\Delta T_{N,\text{con}} = T_0 - T_{e,\text{min}} \quad (6.1)$$

and the characteristic value of the maximum expansion range of the uniform bridge temperature component, $\Delta T_{N,\text{exp}}$ should be taken as

$$\Delta T_{N,\text{exp}} = T_{e,\text{max}} - T_0 \quad (6.2)$$

NOTE 1: The overall range of the uniform bridge temperature component is

$$\Delta T_N = T_{e,\text{max}} - T_{e,\text{min}}$$

AC1 NOTE 2: For bearings and expansion joints the National Annex may specify the maximum expansion range of the uniform bridge temperature component, and the maximum contraction range of the uniform bridge temperature component, if no other provisions are required. The recommended values are $(\Delta T_{N,\text{exp}} + 20)^\circ\text{C}$ and $(\Delta T_{N,\text{con}} + 20)^\circ\text{C}$, respectively. If the temperature at which the bearings and expansion joints, are set is specified, then the recommended values are $(\Delta T_{N,\text{exp}} + 10)^\circ\text{C}$ and $(\Delta T_{N,\text{con}} + 10)^\circ\text{C}$, respectively. **AC1**

NOTE 3: For the design of bearings and expansion joints, the values of the coefficient of expansion given in annex C, Table C.1 may be modified if alternative values have been verified by tests or more detailed studies.

6.1.4 Temperature difference components

(1) Over a prescribed time period heating and cooling of a bridge deck's upper surface will result in a maximum heating (top surface warmer) and a maximum cooling (bottom surface warmer) temperature variation.

(2) The vertical temperature difference may produce effects within a structure due to:

- Restraint of free curvature due to the form of the structure (e.g. portal frame, continuous beams etc.);
- Friction at rotational bearings;
- Non-linear geometric effects (2nd order effects).

(3) In the case of cantilever construction an initial temperature difference may need to be taken into account at the closure of the cantilever.

NOTE: Values of the initial temperature difference may be specified in the National Annex.

6.1.4.1 Vertical linear component (Approach 1)

(1) The effect of vertical temperature differences should be considered by using an equivalent linear temperature difference component (see 6.1.2(2)) with $\Delta T_{M,heat}$ and $\Delta T_{M,cool}$. These values should be applied between the top and the bottom of the bridge deck.

NOTE: Values of $\Delta T_{M,heat}$ and $\Delta T_{M,cool}$ to be used in a Country may be found in its National Annex. Recommended values for $\Delta T_{M,heat}$ and $\Delta T_{M,cool}$ are given in Table 6.1.

Table 6.1: Recommended values of linear temperature difference component for different types of bridge decks for road, foot and railway bridges

Type of Deck	Top warmer than bottom	Bottom warmer than top
	$\Delta T_{M,heat}$ (°C)	$\Delta T_{M,cool}$ (°C)
Type 1: Steel deck	18	13
Type 2: Composite deck	15	18
Type 3: Concrete deck: - concrete box girder - concrete beam - concrete slab	10 15 15	5 8 8
<p>NOTE 1: The values given in the table represent upper bound values of the linearly varying temperature difference component for representative sample of bridge geometries.</p> <p>NOTE 2: The values given in the table are based on a depth of surfacing of 50 mm for road and railway bridges. For other depths of surfacing these values should be multiplied by the factor k_{sur}. Recommended values for the factor k_{sur} is given in Table 6.2.</p>		

Table 6.2: Recommended values of k_{sur} to account for different surfacing thickness

Road, foot and railway bridges						
Surface Thickness	Type 1		Type 2		Type 3	
	Top warmer than bottom	Bottom warmer than top	Top warmer than bottom	Bottom warmer than top	Top warmer than bottom	Bottom warmer than top
[mm]	k_{sur}	k_{sur}	k_{sur}	k_{sur}	k_{sur}	k_{sur}
unsurfaced	0,7	0,9	0,9	1,0	0,8	1,1
water-proofed ¹⁾	1,6	0,6	1,1	0,9	1,5	1,0
50	1,0	1,0	1,0	1,0	1,0	1,0
100	0,7	1,2	1,0	1,0	0,7	1,0
150	0,7	1,2	1,0	1,0	0,5	1,0
ballast (750 mm)	0,6	1,4	0,8	1,2	0,6	1,0
¹⁾ These values represent upper bound values for dark colour						

6.1.4.2 Vertical temperature components with non-linear effects (Approach 2)

(1) The effect of the vertical temperature differences should be considered by including a non-linear temperature difference component (see 6.1.2.2).

AC1 NOTE 1: Values of vertical temperature differences for bridge decks to be used in a Country may be found in its National Annex. Recommended values are given in Figures 6.2a - 6.2c and are valid for 40 mm surfacing depths for deck type 1 and 100 mm for deck types 2 and 3. For other depths of surfacing see Annex B. In these figures "heating" refers to conditions such that solar radiation and other effects cause a gain in heat through the top surface of the bridge deck. Conversely, "cooling" refers to conditions such that heat is lost from the top surface of the bridge deck as a result of re-radiation and other effects. **AC1**

NOTE 2: The temperature difference ΔT incorporates ΔT_M and ΔT_E (see 4(3)) together with a small part of component ΔT_N ; this latter part is included in the uniform bridge temperature component (see 6.1.3).

Type of Construction	Temperature Difference (ΔT)	
	(a) Heating	(b) Cooling
 <p>1a. Steel deck on steel girders</p>	 <p> $h_1 = 0.1\text{m}$ $h_2 = 0.2\text{m}$ $h_3 = 0.3\text{m}$ </p> <p> $\Delta T_1 = 24^\circ\text{C}$ $\Delta T_2 = 14^\circ\text{C}$ $\Delta T_3 = 8^\circ\text{C}$ $\Delta T_4 = 4^\circ\text{C}$ </p>	 <p> $\Delta T_1 = -6^\circ\text{C}$ $h_1 = 0.5\text{m}$ </p>
 <p>1b. Steel deck on steel truss or plate girders</p>	 <p> $h_1 = 0.5\text{m}$ $\Delta T_1 = 21^\circ\text{C}$ </p>	 <p> $\Delta T_1 = -5^\circ\text{C}$ $h_1 = 0.1\text{m}$ </p>

Figure 6.2a: Temperature differences for bridge decks - Type 1 : Steel Decks

*Note: The temperature difference ΔT incorporates ΔT_w and ΔT_f (see 4.3) together with a small part of component ΔT_w : this latter part has been included in the uniform bridge temperature component (see 6.1.3).

AC1

Type of Construction	Temperature Difference (ΔT)																									
	(a) Heating	(b) Cooling																								
 <p>100mm surfacing</p> <p>100mm surfacing</p> <p>h</p> <p>h</p>	<p>Normal Procedure</p>  <p>$h_1 = 0.6h$ $h_2 = 0.4m$</p> <table border="1"> <thead> <tr> <th>h</th> <th>ΔT_1</th> <th>ΔT_2</th> </tr> <tr> <th>m</th> <th>$^{\circ}C$</th> <th>$^{\circ}C$</th> </tr> </thead> <tbody> <tr> <td>0.2</td> <td>13</td> <td>4</td> </tr> <tr> <td>0.3</td> <td>16</td> <td>4</td> </tr> </tbody> </table>	h	ΔT_1	ΔT_2	m	$^{\circ}C$	$^{\circ}C$	0.2	13	4	0.3	16	4	<p>Normal Procedure</p>  <table border="1"> <thead> <tr> <th>h</th> <th>ΔT_1</th> <th>ΔT_2</th> </tr> <tr> <th>m</th> <th>$^{\circ}C$</th> <th>$^{\circ}C$</th> </tr> </thead> <tbody> <tr> <td>0.2</td> <td>-3.5</td> <td>-8</td> </tr> <tr> <td>0.3</td> <td>-5.0</td> <td>-8</td> </tr> </tbody> </table>	h	ΔT_1	ΔT_2	m	$^{\circ}C$	$^{\circ}C$	0.2	-3.5	-8	0.3	-5.0	-8
	h	ΔT_1	ΔT_2																							
m	$^{\circ}C$	$^{\circ}C$																								
0.2	13	4																								
0.3	16	4																								
h	ΔT_1	ΔT_2																								
m	$^{\circ}C$	$^{\circ}C$																								
0.2	-3.5	-8																								
0.3	-5.0	-8																								
<p>Simplified Procedure</p>  <p>$\Delta T_1 = 10^{\circ}C$</p>	<p>Simplified Procedure</p>  <p>$\Delta T_1 = -10^{\circ}C$ $h_1 = 0.6h$ $h_2 = 0.4m$</p>																									
<p>2 Concrete deck on steel box, truss or plate girders</p> <p>Note: For composite bridges the simplified procedure given above may be used, giving upper bound thermal effects. Values for ΔT in this procedure are indicative and may be used unless specific values are given in the National Annex.</p>																										

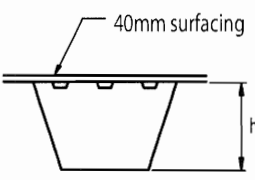
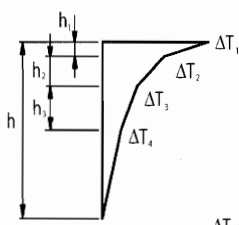
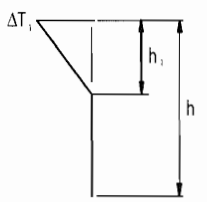
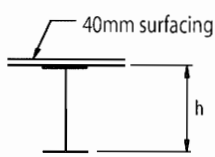
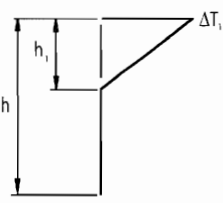
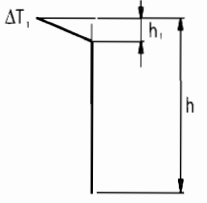
Figure 6.2b: Temperature differences for bridge decks - Type 2 : Composite Decks

*Note: The temperature difference ΔT incorporates ΔT_M and ΔT_E (see 4.3) together with a small part of component ΔT_U : this latter part has been included in the uniform bridge temperature component (see 6.1.3).

AC1

Type of Construction	Temperature Difference (ΔT)																																																								
	(a) Heating	(b) Cooling																																																							
 3a. Concrete slab																																																									
 3b. Concrete beams	<p> $h_1 = 0.3h$ but $\leq 0.15m$ $h_2 = 0.3h$ but $\geq 0.10m$ but $\leq 0.25m$ $h_3 = 0.3h$ but $\leq (0.10m +$ surfacing depth in metres) (for thin slabs, h, is limited by $h - h_1 - h_3$) </p>	<p> $h_1 = h_3 = 0.20h$ but $\leq 0.25m$ $h_2 = h_2 = 0.25h$ but $\geq 0.20m$ </p>																																																							
 3c. Concrete box girder	<table border="1"> <thead> <tr> <th>h</th> <th>ΔT_1</th> <th>ΔT_2</th> <th>ΔT_3</th> </tr> </thead> <tbody> <tr> <td>≤ 0.2</td> <td>8.5</td> <td>3.5</td> <td>0.5</td> </tr> <tr> <td>0.4</td> <td>12.0</td> <td>3.0</td> <td>1.5</td> </tr> <tr> <td>0.6</td> <td>13.0</td> <td>3.0</td> <td>2.0</td> </tr> <tr> <td>≥ 0.8</td> <td>13.0</td> <td>3.0</td> <td>2.5</td> </tr> </tbody> </table>	h	ΔT_1	ΔT_2	ΔT_3	≤ 0.2	8.5	3.5	0.5	0.4	12.0	3.0	1.5	0.6	13.0	3.0	2.0	≥ 0.8	13.0	3.0	2.5	<table border="1"> <thead> <tr> <th>h</th> <th>ΔT_1</th> <th>ΔT_2</th> <th>ΔT_3</th> <th>ΔT_4</th> </tr> </thead> <tbody> <tr> <td>≤ 0.2</td> <td>-2.0</td> <td>-0.5</td> <td>-0.5</td> <td>-1.5</td> </tr> <tr> <td>0.4</td> <td>-4.5</td> <td>-1.4</td> <td>-1.0</td> <td>-3.5</td> </tr> <tr> <td>0.6</td> <td>-6.5</td> <td>-1.8</td> <td>-1.5</td> <td>-5.0</td> </tr> <tr> <td>0.8</td> <td>-7.6</td> <td>-1.7</td> <td>-1.5</td> <td>-6.0</td> </tr> <tr> <td>1.0</td> <td>-8.0</td> <td>-1.5</td> <td>-1.5</td> <td>-6.3</td> </tr> <tr> <td>≥ 1.5</td> <td>-8.4</td> <td>-0.5</td> <td>-1.0</td> <td>-6.5</td> </tr> </tbody> </table>	h	ΔT_1	ΔT_2	ΔT_3	ΔT_4	≤ 0.2	-2.0	-0.5	-0.5	-1.5	0.4	-4.5	-1.4	-1.0	-3.5	0.6	-6.5	-1.8	-1.5	-5.0	0.8	-7.6	-1.7	-1.5	-6.0	1.0	-8.0	-1.5	-1.5	-6.3	≥ 1.5	-8.4	-0.5	-1.0	-6.5
h	ΔT_1	ΔT_2	ΔT_3																																																						
≤ 0.2	8.5	3.5	0.5																																																						
0.4	12.0	3.0	1.5																																																						
0.6	13.0	3.0	2.0																																																						
≥ 0.8	13.0	3.0	2.5																																																						
h	ΔT_1	ΔT_2	ΔT_3	ΔT_4																																																					
≤ 0.2	-2.0	-0.5	-0.5	-1.5																																																					
0.4	-4.5	-1.4	-1.0	-3.5																																																					
0.6	-6.5	-1.8	-1.5	-5.0																																																					
0.8	-7.6	-1.7	-1.5	-6.0																																																					
1.0	-8.0	-1.5	-1.5	-6.3																																																					
≥ 1.5	-8.4	-0.5	-1.0	-6.5																																																					

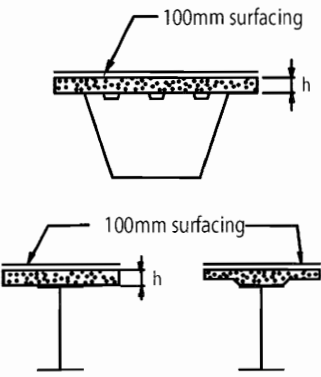
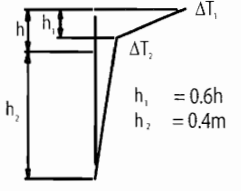
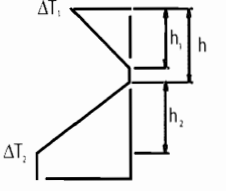
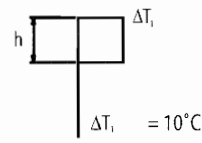
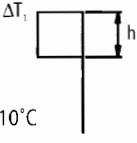
Figure 6.2c: Temperature differences for bridge decks - Type 3 : Concrete Decks

*Note: The temperature difference ΔT incorporates ΔT_u and ΔT_s (see 4.3) together with a small part of component ΔT_u ; this latter part has been included in the uniform bridge temperature component (see 6.1.3).

6.1.4.3 Horizontal components

(1) In general, the temperature difference component need only be considered in the vertical direction. In particular cases however (for example when the orientation or configuration of the bridge results in one side being more highly exposed to sunlight than the other side), a horizontal temperature difference component should be considered.

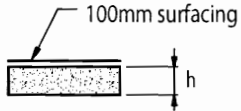
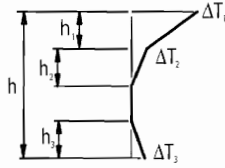
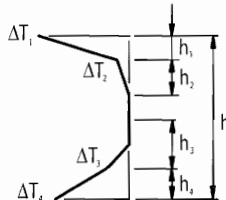
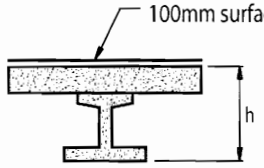
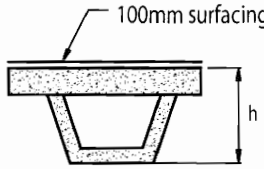
NOTE: The National annex may specify numerical values for the temperature difference. If no other information is available and no indications of higher values exist, 5°C may be recommended as a linear temperature difference between the outer edges of the bridge independent of the width of the bridge.

6.1.4.4 Temperature difference components within walls of concrete box girders

(1) Care should be exercised in the design of large concrete box girder bridges where significant temperature differences can occur between the inner and outer web walls of such structures.

NOTE: The National annex may specify numerical values for the temperature difference. The recommended value for a linear temperature difference is 15°C.

6.1.5 Simultaneity of uniform and temperature difference components

(1) If it is necessary to take into account both the temperature difference $\Delta T_{M,heat}$ (or $\Delta T_{M,cool}$) and the maximum range of uniform bridge temperature component $\Delta T_{N,exp}$ (or $\Delta T_{N,con}$) assuming simultaneity (e.g. in case of frame structures) the following expression may be used (which should be interpreted as load combinations):

$$\Delta T_{M,heat} \text{ (or } \Delta T_{M,cool}) + \omega_N \Delta T_{N,exp} \text{ (or } \Delta T_{N,con}) \quad (6.3)$$

or

$$\omega_M \Delta T_{M,heat} \text{ (or } \Delta T_{M,cool}) + \Delta T_{N,exp} \text{ (or } \Delta T_{N,con}) \quad (6.4)$$

where the most adverse effect should be chosen.

NOTE 1: The National annex may specify numerical values of ω_N and ω_M . If no other information is available, the recommended values for ω_N and ω_M are:

$$\omega_N = 0,35$$

$$\omega_M = 0,75.$$

NOTE 2: Where both linear and non-linear vertical temperature differences are used (see 6.1.4.2) ΔT_M should be replaced by ΔT which includes ΔT_M and ΔT_E .

6.1.6 Differences in the uniform temperature component between different structural elements

(1) In structures where differences in the uniform temperature component between different element types may cause adverse load effects, these effects should be taken into account.

NOTE: The National annex may give values for the differences in the uniform temperature component. Recommended values are:

- 15°C between main structural elements (e.g. tie and arch); and
- 10°C and 20°C for light and dark colour respectively between suspension/stay cables and deck (or tower).

(2) These effects should be considered in addition to the effects resulting from a uniform temperature component in all elements, determined from 6.1.3.

6.2 Bridge Piers

6.2.1 Consideration of thermal actions

(1)^P Temperature differences between the outer faces of bridge piers, hollow or solid, shall be considered in the design.

NOTE: The design procedure to be used in a Country may be found in its National annex. If no procedure is given an equivalent linear temperature difference may be assumed.

(2) Overall temperature effects of piers should be considered, when these can lead to restraining forces or movements in the surrounding structures.

6.2.2 Temperature differences

(1) For concrete piers (hollow or solid), the linear temperature differences between opposite outer faces should be taken into account.

NOTE: The National annex may specify values for linear temperature differences. In the absence of detailed information the recommended value is 5°C.

(2) For walls the linear temperature differences between the inner and outer faces should be taken into account.

NOTE 1: The National annex may specify values for linear temperature differences. In the absence of detailed information the recommended value is 15°C.

NOTE 2: When considering temperature differences for metal columns specialist advice may need to be obtained.

Section 7 Temperature changes in industrial chimneys, pipelines, silos, tanks and cooling towers

7.1 General

(1)P Structures which are in contact with gas flow, liquids or material with different temperatures (e.g. industrial chimneys, pipelines, silos, tanks and cooling towers) shall be designed where relevant for the following conditions:

- thermal actions from climatic effects due to the variation of shade air temperature and solar radiation,
- temperature distribution for normal and abnormal process conditions,
- effects arising from interaction between the structure and its contents during thermal changes (e.g. shrinkage of the structure against stiff solid contents or expansion of solid contents during heating or cooling).

NOTE 1: Values of the operating process temperature may be obtained from the particular project.

NOTE 2: For the operating process temperatures of chimneys see EN 13084-1.

NOTE 3: Containment structures may be subjected to thermally induced changes in shape arising from heating/cooling effects of either the contents or their surrounding external environment.

NOTE 4: No further guidance on the effect of shrinkage against stiff solid contents is given in this standard. See EN 1991-4 for this effect in silos.

7.2 Temperature components

7.2.1 Shade air temperature

(1)P Values of minimum and maximum shade air temperatures for the site location shall be obtained, e.g. from national maps of isotherms.

NOTE: Information (e.g. maps of isotherms) on minimum and maximum shade air temperatures to be used in a Country may be found in its National annex.

(2) These shade air temperatures should be appropriate to mean sea level in open country with an annual probability of being exceeded of 0,02. annex A includes adjustments for other values of probabilities, height above sea level and local conditions e.g. frost pockets.

(3) For circumstances where an annual probability of being exceeded of 0,02 is deemed inappropriate, e.g. during execution (see EN1991-1-6 "Actions during

execution”), the values of minimum (or maximum) shade air temperature should be modified in accordance with annex A.

7.2.2 Flue gas, heated liquids and heated materials temperature

(1) Values of maximum and minimum flue gas, liquids and materials with different temperatures should be specified for the particular project.

7.2.3 Element temperature

(1) The derivation of values of element temperature will depend on the material configuration, orientation and location of the element and will be a function of the maximum and minimum shade air temperature, the external solar radiation, and the internal operating temperature.

NOTE: General rules for the determination of temperature profiles are given in annex D. See also 7.5.

7.3 Consideration of temperature components

(1)P Both the uniform temperature component of the temperature distribution (see Figure 4.1 (a)) and the linearly varying temperature difference component (see Figure 4.1 (b)) shall be considered for each layer.

(2)P The effect of solar radiation shall be considered in the design.

(3) This effect may be approximated by a step temperature distribution round the structure’s circumference.

(4)P The uniform temperature component and the linearly varying temperature difference component due to process temperature shall be considered for each layer.

7.4 Determination of temperature components

(1)P The uniform and linearly varying temperature components shall be determined taking into account climatic effects and operating conditions.

(2) If specific information on how the element temperature can be correlated with the solar radiation and shade air temperature is available in order to provide values of element temperature, such information should be used to provide design values.

(3)P Values of the uniform temperature component from heated gas flow, liquids and heated materials shall be taken from the project specification. As far as chimneys are concerned these values shall be obtained from EN 13084-1.

(4)P The linearly varying temperature difference component in the wall or its layers shall be taken as arising from the difference between the minimum (or maximum)

shade air temperature on the outer face and the value of the liquid or gas temperature on the inner face, taking into account insulation effects.

NOTE: Temperature profiles may be determined using annex D.

7.5 Values of temperature components (indicative values)

(1) In the absence of any specific information on characteristic values of the element temperature, the following indicative values may be used.

NOTE: These values may be checked against any available data to ensure that they are likely to be upper bound values, for the location and the type of element under consideration.

(2) Values of the maximum and minimum uniform temperature component should be taken as those of the maximum and minimum shade air temperature (see 7.2.1).

(3) For concrete pipelines the linear temperature difference component between the inner and outer faces of the wall should be considered.

NOTE 1: The National annex may specify the values for the linear temperature difference component. The recommended value is 15°C.

NOTE 2: For chimneys see EN 13084-1.

(4) For concrete pipelines a stepped temperature component round the circumference (causing both overall and local thermal effects) should be considered on the basis that one quadrant of its circumference has a mean temperature higher than that of the remainder of the circumference.

NOTE: The value of the difference of temperature may be given in the National annex. The recommended value is 15°C.

(5) When considering steel pipelines, the linear temperature difference component and stepped temperature component round the structure's circumference should be calculated taking into account the operating conditions as set down in the particular project.

NOTE: The rules for steel chimneys are given in EN 13084-1.

7.6 Simultaneity of temperature components

(1) When considering thermal actions due to climatic effects only, the following components take account of simultaneity:

a) uniform temperature component (see 7.5 (2) and Figure 7.1 (a));

b) stepped temperature component (see 7.5 (4) and Figure 7.1 (b));

c) the linear temperature difference component between the inner and the outer faces of the wall (see 7.5 (3) and Figure 7.1 (c)).

(2) When considering a combination of thermal actions due to climatic effects with those due to process effects (heated gas flow, liquids or heated materials) the following components should be combined:

- uniform temperature component (see 7.4 (3));
- linear temperature difference component (see 7.4 (4));
- stepped component (see 7.5 (4)).

(3) The stepped temperature component should be considered to act simultaneously with wind.

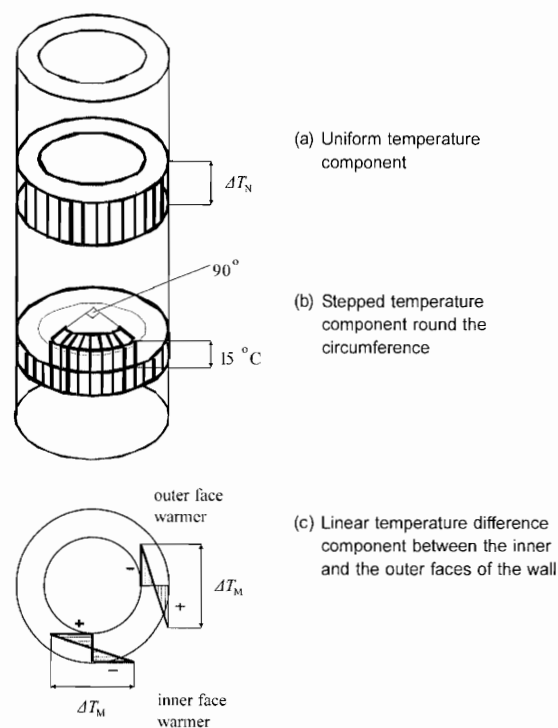

Key

- a Uniform temperature component
- b Stepped temperature component round the circumference
- c Linear temperature difference component between the inner and the outer faces of the wall
- 1 Outer face warmer
- 2 Inner face warmer

Figure 7.1: Relevant temperature components for pipelines, silos, tanks and cooling towers

Annex A (Normative)

Isotherms of national minimum and maximum shade air temperatures

A.1 General

(1) The values of both annual minimum and annual maximum shade air temperature represent values with an annual probability of being exceeded of 0,02.

NOTE 1: Information (e.g. maps or tables of isotherms) on both annual minimum and annual maximum shade air temperature to be used in a Country may be found in its National annex.

NOTE 2: These values may need to be adjusted for height above sea level. The adjustment procedure is given in the National annex. If no information is available the values of shade air temperature may be adjusted for height above sea level by subtracting 0,5°C per 100 m height for minimum shade air temperatures and 1,0°C per 100 m height for maximum shade air temperatures.

(2) In locations where the minimum values diverge from the values given, such as frost pockets and sheltered low lying areas where the minimum may be substantially lower, or in large conurbations and coastal sites, where the minimum may be higher than that indicated in the relevant figures, these divergences should be taken into consideration using local meteorological data.

(3) The initial temperature T_0 should be taken as the temperature of a structural element at the relevant stage of its restraint (completion). If it is not predictable the average temperature during the construction period should be taken.

AC1 NOTE: The value of T_0 may be specified in the National annex or in a particular project. If no information is available T_0 may be taken as 10 °C. In case of uncertainty concerning sensitivity of the bridge to T_0 , it is recommended that a lower and upper bound of an interval expected for T_0 are considered. AC1

A.2 Maximum and minimum shade air temperature values with an annual probability of being exceeded p other than 0,02

(1) If the value of maximum (or minimum) shade air temperature, $T_{\max,p}$ ($T_{\min,p}$), is based on an annual probability of being exceeded p other than 0,02, the ratio $T_{\max,p}/T_{\max}$ ($T_{\min,p}/T_{\min}$) may be determined from Figure A.1.

(2) In general $T_{\max,p}$ (or $T_{\min,p}$) may be derived from the following expressions based on a type I extreme value distribution:

$$\text{- for maximum:} \quad T_{\max,p} = T_{\max} \{k_1 - k_2 \ln [- \ln (1-p)] \} \quad (\text{A.1})$$

$$\text{- for minimum:} \quad T_{\min,p} = T_{\min} \{k_3 + k_4 \ln [- \ln (1-p)] \} \quad (\text{A.2})$$

where:

T_{\max} (T_{\min}) is the value of maximum (minimum) shade air temperature with an annual probability of being exceeded of 0,02;

$$k_1 = (uc) / \{ (uc) + 3,902 \} \quad (\text{A.3})$$

$$k_2 = 1 / \{ (uc) + 3,902 \} \quad (\text{A.4})$$

where:

u, c are the mode and scale parameters of annual maximum shade air temperature distribution.

$$k_3 = (uc) / \{ (uc) - 3,902 \} \quad (\text{A.5})$$

$$k_4 = 1 / \{ (uc) - 3,902 \} \quad (\text{A.6})$$

The parameters u and c are dependent on the mean value m and the standard deviation σ of type I extreme value distribution:

$$\begin{aligned} \text{for maximum} \quad u &= m - 0,57722 / c \\ c &= 1,2825 / \sigma \end{aligned} \quad (\text{A.7})$$

$$\begin{aligned} \text{for minimum} \quad u &= m + 0,57722 / c \\ c &= 1,2825 / \sigma \end{aligned} \quad (\text{A.8})$$

AC1 The ratios $T_{\max,p}/T_{\max}$ and $T_{\min,p}/T_{\min}$ respectively may then be taken from Figure A.1, which is based on the recommended values of $k_1 - k_4$ given in NOTE1. **AC1**

NOTE1: The National annex may specify the values of the coefficients k_1 , k_2 , k_3 and k_4 based on the values of parameters u and c . If no other information is available the following values are recommended:

$$k_1 = 0,781;$$

$$k_2 = 0,056;$$

$$k_3 = 0,393;$$

$$k_4 = -0,156.$$

NOTE 2: Expression (A.2) and Figure A.1 can only be used if T_{\min} is negative.

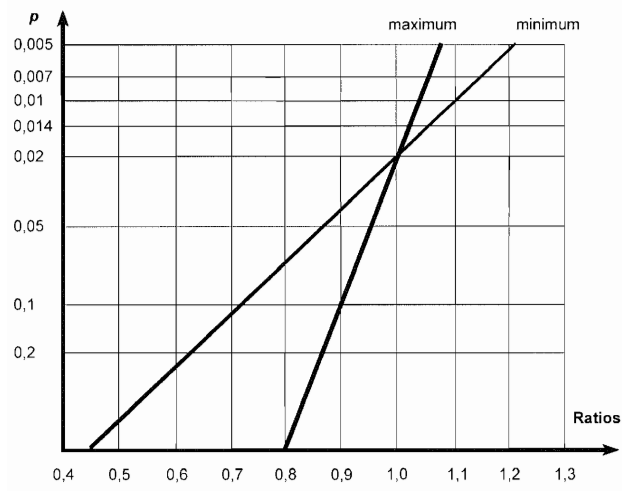

Figure A.1: Ratios $T_{\max,p} / T_{\max}$ and $T_{\min,p} / T_{\min}$

Annex B (Normative)

Temperature differences for various surfacing depths

(1) Temperature difference profiles given in Figures 6.2a - 6.2c are valid for 40 mm surfacing depths for deck type 1 and 100 mm surfacing depths for types 2 and 3.

NOTE: The National annex may give values for other depths. Recommended values are given in the following tables:

- Table B.1 for deck type 1;
- Table B.2 for deck type 2;
- Table B.3 for deck type 3.

Table B.1 – Recommended values of ΔT for deck type 1

Surfacing thickness	Temperature difference				
	Heating				Cooling
	ΔT_1	ΔT_2	ΔT_3	ΔT_4	ΔT_1
mm	°C	°C	°C	°C	°C
unsurfaced	30	16	6	3	8
20	27	15	9	5	6
40	24	14	8	4	6

Table B.2 – Recommended values of ΔT for deck type 2

Depth of slab (h)	Surfacing thickness	Temperature difference	
		Heating	Cooling
		ΔT_1	ΔT_1
m	mm	°C	°C
0,2	unsurfaced	16,5	5,9
	waterproofed ¹⁾	23,0	5,9
	50	18,0	4,4
	100	13,0	3,5
	150	10,5	2,3
0,3	200	8,5	1,6
	unsurfaced	18,5	9,0
	waterproofed ¹⁾	26,5	9,0
	50	20,5	6,8
	100	16,0	5,0
	150	12,5	3,7
	200	10,0	2,7

¹⁾ These values represent upper bound values for dark colour

Table B.3 – Recommended values of ΔT for deck type 3

Depth of slab (h)	Surfacing thickness	Temperature difference						
		Heating			Cooling			
		ΔT_1	ΔT_2	ΔT_3	ΔT_1	ΔT_2	ΔT_3	ΔT_4
m	mm	°C	°C	°C	°C	°C	°C	°C
0,2	unsurfaced	12,0	5,0	0,1	4,7	1,7	0,0	0,7
	waterproofed ¹⁾	19,5	8,5	0,0	4,7	1,7	0,0	0,7
	50	13,2	4,9	0,3	3,1	1,0	0,2	1,2
	100	8,5	3,5	0,5	2,0	0,5	0,5	1,5
	150	5,6	2,5	0,2	1,1	0,3	0,7	1,7
	200	3,7	2,0	0,5	0,5	0,2	1,0	1,8
0,4	unsurfaced	15,2	4,4	1,2	9,0	3,5	0,4	2,9
	waterproofed ¹⁾	23,6	6,5	1,0	9,0	3,5	0,4	2,9
	50	17,2	4,6	1,4	6,4	2,3	0,6	3,2
	100	12,0	3,0	1,5	4,5	1,4	1,0	3,5
	150	8,5	2,0	1,2	3,2	0,9	1,4	3,8
	200	6,2	1,3	1,0	2,2	0,5	1,9	4,0
0,6	unsurfaced	15,2	4,0	1,4	11,8	4,0	0,9	4,6
	waterproofed ¹⁾	23,6	6,0	1,4	11,8	4,0	0,9	4,6
	50	17,6	4,0	1,8	8,7	2,7	1,2	4,9
	100	13,0	3,0	2,0	6,5	1,8	1,5	5,0
	150	9,7	2,2	1,7	4,9	1,1	1,7	5,1
	200	7,2	1,5	1,5	3,6	0,6	1,9	5,1
0,8	unsurfaced	15,4	4,0	2,0	12,8	3,3	0,9	5,6
	waterproofed ¹⁾	23,6	5,0	1,4	12,8	3,3	0,9	5,6
	50	17,8	4,0	2,1	9,8	2,4	1,2	5,8
	100	13,5	3,0	2,5	7,6	1,7	1,5	6,0
	150	10,0	2,5	2,0	5,8	1,3	1,7	6,2
	200	7,5	2,1	1,5	4,5	1,0	1,9	6,0
1,0	unsurfaced	15,4	4,0	2,0	13,4	3,0	0,9	6,4
	waterproofed ¹⁾	23,6	5,0	1,4	13,4	3,0	0,9	6,4
	50	17,8	4,0	2,1	10,3	2,1	1,2	6,3
	100	13,5	3,0	2,5	8,0	1,5	1,5	6,3
	150	10,0	2,5	2,0	6,2	1,1	1,7	6,2
	200	7,5	2,1	1,5	4,3	0,9	1,9	5,8
1,5	unsurfaced	15,4	4,5	2,0	13,7	1,0	0,6	6,7
	waterproofed ¹⁾	23,6	5,0	1,4	13,7	1,0	0,6	6,7
	50	17,8	4,0	2,1	10,6	0,7	0,8	6,6
	100	13,5	3,0	2,5	8,4	0,5	1,0	6,5
	150	10,0	2,5	2,0	6,5	0,4	1,1	6,2
	200	7,5	2,1	1,5	5,0	0,3	1,2	5,6

¹⁾ These values represent upper bound values for dark colour

Annex C
(Informative)

Coefficients of linear expansion

(1) For the determination of action effects due to temperature components, Table C.1 gives values for the coefficient of linear expansion for a selection of commonly used materials.

Table C.1: Coefficients of linear expansion

Material	α_T ($\times 10^{-6}/^{\circ}\text{C}$)
Aluminium, aluminium alloy	24
Stainless steel	16
Structural steel, wrought or cast iron	12 (see Note 6)
Concrete except as under	10
Concrete, lightweight aggregate	7
Masonry	6-10 (see Notes)
Glass	(see Note 4)
Timber, along grain	5
Timber, across grain	30-70 (see Notes)

NOTE 1: For other materials special advice should be sought.

NOTE 2: The values given should be used for the derivation of thermal actions, unless other values can be verified by tests or more detailed studies.

NOTE 3: Values for masonry will vary depending on the type of brickwork; values for timber across the grain can vary considerably according to the type of timber.

NOTE 4: For more detailed information see:

EN 572-1: Glass in Building - Basic soda lime silicate glass - Part 1: Definitions and general physical and mechanical properties;

prEN 1748-1-1: Glass in Building - Special basic products - Part 1-1: Borosilicate glass – Definition and description;

prEN 1748-2-1: Glass in Building - Special basic products - Part 1-1 : Glass ceramics – Definition and description;

prEN 14178-1: Glass in Building – Basic alkaline earth silicate glass products – Part 1: Float glass

NOTE 5: For some materials such as masonry and timber other parameters (e.g. moisture content) also need to be considered. See EN 1995 -EN 1996.

NOTE 6 : For composite structures the coefficient of linear expansion of the steel component may be taken as equal to $10 \times 10^{-6}/^{\circ}\text{C}$ to neglect restraining effects from different α_T -values.

Annex D (Informative)

Temperature profiles in buildings and other construction works

(1) Temperature profiles may be determined using the thermal transmission theory. In the case of a simple sandwich element (e.g. slab, wall, shell) under the assumption that local thermal bridges do not exist a temperature $T(x)$ at a distance x from the inner surface of the cross section may be determined assuming steady thermal state as

$$T(x) = T_{in} - \frac{R(x)}{R_{tot}}(T_{in} - T_{out}) \quad (D.1)$$

where:

T_{in}	is the air temperature of the inner environment
T_{out}	is the temperature of the outer environment
R_{tot}	is the total thermal resistance of the element including resistance of both surfaces
$R(x)$	is the thermal resistance at the inner surface and of the element from the inner surface up to the point x (see Figure D.1).

(2) The resistance values R_{tot} , and $R(x)$ [m^2K/W] may be determined using the coefficient of heat transfer and coefficients of thermal conductivity given in EN ISO 6946 (1996) and EN ISO 13370 (1998):

$$R_{tot} = R_{in} + \sum_i \frac{h_i}{\lambda_i} + R_{out} \quad (D.2)$$

where:

R_{in}	is the thermal resistance at the inner surface [m^2K/W]
R_{out}	is the thermal resistance at the outer surface [m^2K/W],
λ_i	is the thermal conductivity and h_i [m] is the thickness of the layer i , [$W/(mK)$]

$$R(x) = R_{in} + \sum_i \frac{h_i}{\lambda_i} \quad (D.3)$$

where layers (or part of a layer) from the inner surface up to point x (see Figure D.1) are considered only.

NOTE: In buildings the thermal resistance $R_{in} = 0,10$ to $0,17$ [m^2K/W] (depending on the orientation of the heat flow), and $R_{out} = 0,04$ (for all orientations). The thermal conductivity λ_i for concrete (of volume weight from 21 to 25 kN/m^3) varies from $\lambda_i = 1,16$ to $1,71$ [$W/(mK)$].

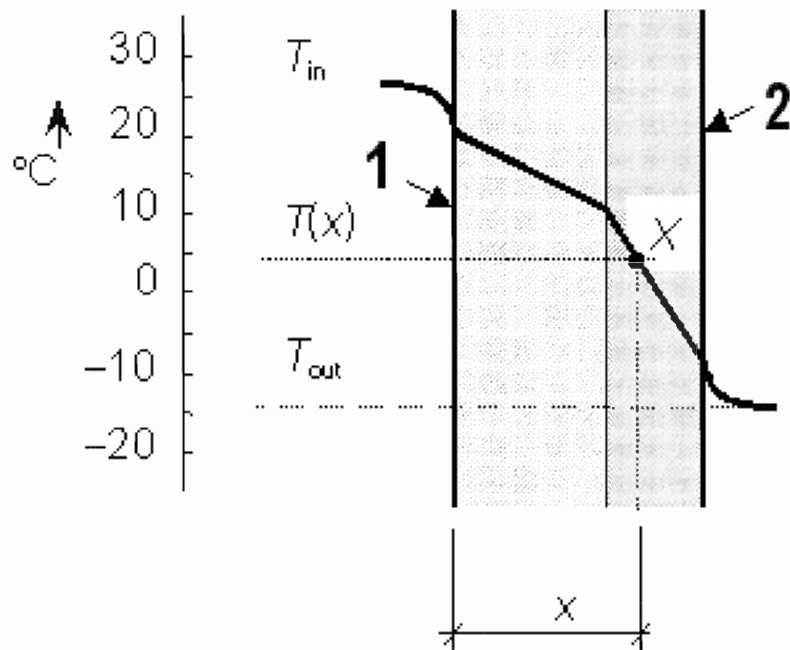
**Key**

- 1 Inner surface
- 2 Outer surface

Figure D.1: Thermal profile of a two-layer element.

BS EN 1991-1-5: 2003

EN 1991-1-5: 2003 (E)

Bibliography

EN 1991-2 Eurocode 1: Actions on structures - Part 2: Traffic loads on bridges

EN 1991-4 Eurocode 1: Basis of design and actions on structures - Part 4: Silos and tanks

