

# *The European Union*

## EDICT OF GOVERNMENT

In order to promote public education and public safety, equal justice for all, a better informed citizenry, the rule of law, world trade and world peace, this legal document is hereby made available on a noncommercial basis, as it is the right of all humans to know and speak the laws that govern them.

EN 1991-1-3 (2003) (English): Eurocode 1: Actions on structures - Part 1-3: General actions - Snow loads  
[Authority: The European Union Per Regulation 305/2011, Directive 98/34/EC, Directive 2004/18/EC]



BLANK PAGE



English version

## Eurocode 1 - Actions on structures - Part 1-3: General actions - Snow loads

Eurocode 1 - Actions sur les structures - Partie 1-3: Actions  
générales - Charges de neige

Eurocode 1 - Einwirkungen auf Tragwerke - Teil 1-3:  
Allgemeine Einwirkungen-Schneelasten

This European Standard was approved by CEN on 9 October 2002.

CEN members are bound to comply with the CEN/CENELEC Internal Regulations which stipulate the conditions for giving this European Standard the status of a national standard without any alteration. Up-to-date lists and bibliographical references concerning such national standards may be obtained on application to the Management Centre or to any CEN member.

This European Standard exists in three official versions (English, French, German). A version in any other language made by translation under the responsibility of a CEN member into its own language and notified to the Management Centre has the same status as the official versions.

CEN members are the national standards bodies of Austria, Belgium, Czech Republic, Denmark, Finland, France, Germany, Greece, Hungary, Iceland, Ireland, Italy, Luxembourg, Malta, Netherlands, Norway, Portugal, Slovakia, Spain, Sweden, Switzerland and United Kingdom.



EUROPEAN COMMITTEE FOR STANDARDIZATION  
COMITÉ EUROPÉEN DE NORMALISATION  
EUROPÄISCHES KOMITEE FÜR NORMUNG

Management Centre: rue de Stassart, 36 B-1050 Brussels

| <b>CONTENTS</b>   |  | <b>Page</b> |
|---|--|-------------|
| <b>Foreword</b>   |  | <b>4</b>    |
| <b>1. Section 1 General</b>                                 |  | <b>8</b>    |
| 1.1. Scope  |  | 8           |
| 1.2. Normative references                                   |  | 9           |
| 1.3. Assumptions  |  | 9           |
| 1.4. Distinction between Principles and Application Rules   |  | 9           |
| 1.5. Design assisted by testing                             |  | 9           |
| 1.6. Terms and Definitions                                  |  | 10          |
| 1.7. Symbols  |  | 11          |
| <b>2. Section 2 Classification of actions</b>               |  | <b>13</b>   |
| <b>3. Section 3 Design situations</b>                       |  | <b>14</b>   |
| 3.1. General  |  | 14          |
| 3.2. Normal conditions                                      |  | 14          |
| 3.3. Exceptional conditions                                 |  | 14          |
| <b>4. Section 4 Snow load on the ground</b>                 |  | <b>16</b>   |
| 4.1. Characteristic values                                  |  | 16          |
| 4.2. Other representative values                            |  | 16          |
| 4.3. Treatment of exceptional snow loads on the ground      |  | 17          |
| <b>5. Section 5 Snow load on roofs</b>                      |  | <b>17</b>   |
| 5.1. Nature of the load                                     |  | 17          |
| 5.2. Load arrangements                                      |  | 18          |
| 5.3. Roof shape coefficients                                |  | 20          |
| 5.3.1. General  |  | 20          |
| 5.3.2. Monopitch roofs                                      |  | 21          |
| 5.3.3. Pitched roofs  |  | 22          |
| 5.3.4. Multi-span roofs                                     |  | 23          |
| 5.3.5. Cylindrical roofs                                    |  | 24          |
| 5.3.6. Roof abutting and close to taller construction works |  | 25          |
| <b>6. Section 6 Local effects</b>                           |  | <b>28</b>   |
| 6.1. General  |  | 28          |
| 6.2. Drifting at projections and obstructions               |  | 28          |
| 6.3. Snow overhanging the edge of a roof                    |  | 29          |
| 6.4. Snow loads on snowguards and other obstacles           |  | 30          |

|   |           |
|---|-----------|
| <b>ANNEX A</b>  | <b>31</b> |
| <b>Design situations and load arrangements to be used for different locations</b> | <b>31</b> |
| <b>ANNEX B</b>  | <b>33</b> |
| <b>Snow load shape coefficients for exceptional snow drifts</b>                   | <b>33</b> |
| <b>ANNEX C</b>  | <b>38</b> |
| <b>European Ground Snow Load Maps</b>   | <b>38</b> |
| <b>ANNEX D</b>  | <b>53</b> |
| <b>Adjustment of the ground snow load according to return period</b>              | <b>53</b> |
| <b>ANNEX E</b>  | <b>55</b> |
| <b>Bulk weight density of snow</b>  | <b>55</b> |
| <b>Bibliography</b>   | <b>56</b> |

## Foreword

This document (EN 1991-1-3:2003) has been prepared by Technical Committee CEN/TC250 "Structural Eurocodes", the Secretariat of which is held by BSI.

This European Standard shall be given the status of a National Standard, either by publication of an identical text or by endorsement, at the latest by January 2004, and conflicting National Standards shall be withdrawn at the latest by March 2010.

This document supersedes ENV 1991-2-3:1995.

CEN/TC250 is responsible for all Structural Eurocodes.

Annexes A and B are normative. Annexes C, D and E are informative.

According to the CEN-CENELEC Internal Regulations, the National Standard Organisations of the following countries are bound to implement this European Standard: Austria, Belgium, Czech Republic, Denmark, Finland, France, Germany, Greece, Hungary, Iceland, Ireland, Italy, Luxembourg, Malta, Netherlands, Norway, Portugal, Slovakia, Spain, Sweden, Switzerland and the United Kingdom.

### Background of the Eurocode programme

In 1975, the Commission of the European Community decided on an action programme in the field of construction, based on article 95 of the Treaty. The objective of the programme was the elimination of technical obstacles to trade and the harmonisation of technical specifications.

Within this action programme, the Commission took the initiative to establish a set of harmonised technical rules for the design of construction works which, in a first stage, would serve as an alternative to the national rules in force in the Member States and, ultimately, would replace them.

For fifteen years, the Commission, with the help of a Steering Committee with Representatives of Member States, conducted the development of the Eurocodes programme, which led to the first generation of European codes in the 1980's.

In 1989, the Commission and the Member States of the EU and EFTA decided, on the basis of an agreement<sup>1</sup> between the Commission and CEN, to transfer the preparation and the publication of the Eurocodes to the CEN through a series of Mandates, in order to provide them with a future status of European Standard (EN). This links *de facto* the Eurocodes with the provisions of all the Council's Directives and/or Commission's Decisions dealing with European

---

<sup>1</sup> Agreement between the Commission of the European Communities and the European Committee for Standardisation (CEN) concerning the work on EUROCODES for the design of building and civil engineering works (BC/CEN/03/89).

standards (e.g. the Council Directive 89/106/EEC on construction products and Council Directives 93/37/EEC, 92/50/EEC and 89/440/EEC on public works and services and equivalent EFTA Directives initiated in pursuit of setting up the internal market).

The Structural Eurocode programme comprises the following standards generally consisting of a number of Parts:

|         |             |   |
|---------|-------------|---|
| EN 1990 | Eurocode:   | Basis of Structural Design                        |
| EN 1991 | Eurocode 1: | Actions on structures                             |
| EN 1992 | Eurocode 2: | Design of concrete structures                     |
| EN 1993 | Eurocode 3: | Design of steel structures                        |
| EN 1994 | Eurocode 4: | Design of composite steel and concrete structures |
| EN 1995 | Eurocode 5: | Design of timber structures                       |
| EN 1996 | Eurocode 6: | Design of masonry structures                      |
| EN 1997 | Eurocode 7: | Geotechnical design                               |
| EN 1998 | Eurocode 8: | Design of structures for earthquake resistance    |
| EN 1999 | Eurocode 9: | Design of aluminium structures                    |

Eurocode standards recognise the responsibility of regulatory authorities in each Member State and have safeguarded their right to determine values related to regulatory safety matters at national level where these continue to vary from State to State.

### Status and field of application of Eurocodes

The Member States of the EU and EFTA recognise that EUROCODES serve as reference documents for the following purposes :

- as a means to prove compliance of building and civil engineering works with the essential requirements of Council Directive 89/106/EEC, particularly Essential Requirement N°1 – Mechanical resistance and stability – and Essential Requirement N°2 – Safety in case of fire ;
- as a basis for specifying contracts for construction works and related engineering services ;
- as a framework for drawing up harmonised technical specifications for construction products (ENs and ETAs)

The Eurocodes, as far as they concern the construction works themselves, have a direct relationship with the Interpretative Documents<sup>2</sup> referred to in Article 12 of the CPD, although they are of a different nature from harmonised product standards<sup>3</sup>. Therefore, technical aspects arising from the Eurocodes

<sup>2</sup> According to Art. 3.3 of the CPD, the essential requirements (ERs) shall be given concrete form in interpretative documents for the creation of the necessary links between the essential requirements and the mandates for hENs and ETAGs/ETAs.

<sup>3</sup> According to Art. 12 of the CPD the interpretative documents shall :

- give concrete form to the essential requirements by harmonising the terminology and the technical bases and indicating classes or levels for each requirement where necessary ;
- indicate methods of correlating these classes or levels of requirement with the technical specifications, e.g. methods of calculation and of proof, technical rules for project design, etc. ;
- serve as a reference for the establishment of harmonised standards and guidelines for European technical approvals.

The Eurocodes, *de facto*, play a similar role in the field of the ER 1 and a part of ER 2.

work need to be adequately considered by CEN Technical Committees and/or EOTA Working Groups working on product standards with a view to achieving a full compatibility of these technical specifications with the Eurocodes.

The Eurocode standards provide common structural design rules for everyday use for the design of whole structures and component products of both a traditional and an innovative nature. Unusual forms of construction or design conditions are not specifically covered and additional expert consideration will be required by the designer in such cases.

### **National Standards implementing Eurocodes**

The National Standards implementing Eurocodes will comprise the full text of the Eurocode (including any annexes), as published by CEN, which may be preceded by a National title page and National foreword, and may be followed by a National Annex.

The National Annex may only contain information on those parameters which are left open in the Eurocode for national choice, known as Nationally Determined Parameters, to be used for the design of buildings and civil engineering works to be constructed in the country concerned, *i.e.* :

- values for partial factors and/or classes where alternatives are given in the Eurocode,
- values to be used where a symbol only is given in the Eurocode,
- country specific data (geographical, climatic etc.), e.g. snow map,
- the procedure to be used where alternative procedures are given in the Eurocode.

It may also contain

- decisions on the application of informative annexes,
- references to non-contradictory complementary information to assist the user to apply the Eurocode.

### **Links between Eurocodes and harmonised technical specifications (ENs and ETAs) for products**

There is a need for consistency between the harmonised technical specifications for construction products and the technical rules for works<sup>4</sup>. Furthermore, all the information accompanying the CE Marking of the construction products which refer to Eurocodes should clearly mention which Nationally Determined Parameters have been taken into account.

### **Introduction - Additional information specific for EN 1991-1-3**

EN 1991 1-3 gives design guidance and actions from snow for the structural design of buildings and civil engineering works.

---

<sup>4</sup> see Art. 3.3 and Art. B2 of the CPD, as well as clauses 4.2, 4.3.1, 4.3.2 and 5.2 of TD 1.



EN 1991 1-3 is intended for clients, designers, contractors and public authorities.

EN 1991 1-3 is intended to be used with EN 1990:2002, the other Parts of EN 1991 and EN 1992- EN 1999 for the design of structures.

### **National Annex for EN1991-1-3**

This standard gives alternative procedures, values and recommendations for classes with notes indicating where national choices may have to be made. Therefore the National Standard implementing EN 1991-1-3 should have a National Annex containing nationally determined parameters to be used for the design of buildings and civil engineering works to be constructed in the relevant country.

National choice is allowed in EN 1991-1-3 through clauses

- 1.1(2), 1.1(3), 1.1(4)
- 2(3), 2(4)
- 3.3(1), 3.3(3),
- 4.1(1), 4.1(2), 4.2(1), 4.3(1)
- 5.2(2), 5.2(5), 5.2(6), 5.2(7), 5.2(8), 5.3.3(4), 5.3.4(3), 5.3.4(4), 5.3.5(1),  
5.3.5(3), 5.3.6(1),
- 6.2(2), 6.3(1), 6.3(2)
- A(1) (through Table A1)

## 1. Section 1 General

### 1.1. Scope

(1) EN 1991-1-3 gives guidance to determine the values of loads due to snow to be used for the structural design of buildings and civil engineering works.

(2) This Part does not apply for sites at altitudes above 1 500 m, unless otherwise specified.

**NOTE:** Advice for the treatment of snow loads for altitudes above 1 500 m may be found in the National Annex. **AC1**

(3) Annex A gives information on design situations and load arrangements to be used for different locations.

**NOTE:** These different locations may be identified by the National Annex.

(4) Annex B gives shape coefficients to be used for the treatment of exceptional snow drifts.

**NOTE:** The use of Annex B is allowed through the National Annex.

(5) Annex C gives characteristic values of snow load on the ground based on the results of work carried out under a contract specific to this Eurocode, to DGIII / D3 of the European Commission.

The objectives of this Annex are:

- to give information to National Competent Authorities to help them to redraft and update their national maps;
- to help to ensure that the established harmonised procedures used to produce the maps in this Annex are used in the member states for treating their basic snow data.

(6) Annex D gives guidance for adjusting the ground snow loads according to the return period.

(7) Annex E gives information on the bulk weight density of snow.

(8) This Part does not give guidance on specialist aspects of snow loading, for example:

- impact snow loads resulting from snow sliding off or falling from a higher roof;
- the additional wind loads which could result from changes in shape or size of the construction works due to the presence of snow or the accretion of ice;
- loads in areas where snow is present all year round;
- ice loading;
- lateral loading due to snow (e.g. lateral loads exerted by drifts);
- snow loads on bridges.

## 1.2. Normative references

This European Standard incorporates by dated or undated references provisions from other publications. These normative references are cited at the appropriate place in the text, and publications are listed hereafter.

For dated references, subsequent amendments to, or revisions of any of these publications apply to this European Standard only when incorporated in it by amendment or revision. For undated references, the latest edition of the publication referred to applies (including amendments).

|                  |  |
|------------------|--|
| EN 1990:2002     | Eurocode: Basis of structural design   |
| EN 1991-1-1:2002 | Eurocode 1: Actions on structures Part 1-1: General actions: Densities self weight and imposed loads for buildings |

**NOTE:** The following European Standards, which are published or in preparation, are cited in normative clauses

|           |   |
|-----------|---|
| EN 1991-2 | Eurocode 1: Actions on structures<br>Part 2: Traffic loads on bridges |
|-----------|---|

## 1.3. Assumptions

The statements and assumptions given in EN 1990:2002, 1.3 apply to EN 1991-1-3.

## 1.4. Distinction between Principles and Application Rules

The rules given in EN 1990:2002, 1.4 apply to EN 1991-1-3.

## 1.5. Design assisted by testing

In some circumstances tests and proven and/or properly validated numerical methods may be used to obtain snow loads on the construction works.

**NOTE:** The circumstances are those agreed for an individual project, with the client and the relevant Authority.

## 1.6. Terms and Definitions

For the purposes of this European standard, a basic list of terms definitions given in EN 1990:2002, 1.5 apply together with the following.

### 1.6.1

#### **characteristic value of snow load on the ground**

snow load on the ground based on an annual probability of exceedence of 0,02, excluding exceptional snow loads.

### 1.6.2

#### **altitude of the site**

height above mean sea level of the site where the structure is to be located, or is already located for an existing structure.

### 1.6.3

#### **exceptional snow load on the ground**

load of the snow layer on the ground resulting from a snow fall which has an exceptionally infrequent likelihood of occurring.

**NOTE:** See notes to 2(3) and 4.3(1).

### 1.6.4

#### **characteristic value of snow load on the roof**

product of the characteristic snow load on the ground and appropriate coefficients.

**NOTE:** These coefficients are chosen so that the probability of the calculated snow load on the roof does not exceed the probability of the characteristic value of the snow load on the ground.

### 1.6.5

#### **undrifted snow load on the roof**

load arrangement which describes the uniformly distributed snow load on the roof, affected only by the shape of the roof, before any redistribution of snow due to other climatic actions.

### 1.6.6

#### **drifted snow load on the roof**

load arrangement which describes the snow load distribution resulting from snow having been moved from one location to another location on a roof, e.g. by the action of the wind.

### 1.6.7

#### **roof snow load shape coefficient**

ratio of the snow load on the roof to the undrifted snow load on the ground, without the influence of exposure and thermal effects.

### 1.6.8

#### **thermal coefficient**

coefficient defining the reduction of snow load on roofs as a function of the heat flux through the roof, causing snow melting.

### 1.6.9

#### **exposure coefficient**

coefficient defining the reduction or increase of load on a roof of an unheated building, as a fraction of the characteristic snow load on the ground.

### 1.6.10

#### **load due to exceptional snow drift**

load arrangement which describes the load of the snow layer on the roof resulting from a snow deposition pattern which has an exceptionally infrequent likelihood of occurring.

## 1.7. Symbols

(1) For the purpose of this European standard, the following symbols apply.

**NOTE:** The notation used is based on ISO 3898

(2) A basic list of notations is given in EN 1990:2002 1.6, and the additional notations below are specific to this Part.

Latin upper case letters

|           |   |
|-----------|---|
| $C_e$     | Exposure coefficient  |
| $C_t$     | Thermal coefficient   |
| $C_{esl}$ | Coefficient for exceptional snow loads                          |
| $A$       | Site altitude above sea level [m]                               |
| $S_e$     | Snow load per metre length due to overhang [kN/m]               |
| $F_s$     | Force per metre length exerted by a sliding mass of snow [kN/m] |

Latin lower case letters

|       |   |
|-------|---|
| $b$   | Width of construction work [m]  |
| $d$   | Depth of the snow layer [m]   |
| $h$   | Height of construction work [m]   |
| $k$   | Coefficient to take account of the irregular shape of snow (see also 6.3) |
| $l_s$ | Length of snow drift or snow loaded area [m]                              |

|          |  |
|----------|--|
| $s$      | Snow load on the roof [kN/m <sup>2</sup> ]   |
| $s_k$    | Characteristic value of snow on the ground at the relevant site [kN/m <sup>2</sup> ] |
| $s_{Ad}$ | Design value of exceptional snow load on the ground [kN/m <sup>2</sup> ]             |

Greek Lower case letters

|          |  |
|----------|--|
| $\alpha$ | Pitch of roof, measured from horizontal [°]  |
| $\beta$  | Angle between the horizontal and the tangent to the curve for a cylindrical roof [°] |
| $\gamma$ | Weight density of snow [kN/m <sup>3</sup> ]  |
| $\mu$    | snow load shape coefficient  |
| $\psi_0$ | Factor for combination value of a variable action                                    |
| $\psi_1$ | Factor for frequent value of a variable action                                       |
| $\psi_2$ | Factor for quasi-permanent value of a variable action                                |

**NOTE:** For the purpose of this standard the units specified in the above list apply.

## 2. Section 2 Classification of actions

(1)P Snow loads shall be classified as variable, fixed actions (see also 5.2), unless otherwise specified in this standard, see EN 1990:2002, 4.1.1 (1)P and 4.1.1 (4).

(2) Snow loads covered in this standard should be classified as static actions, see EN 1990:2002, 4.1.1 (4).

(3) In accordance with EN 1990:2002, 4.1.1 (2), for the particular condition defined in 1.6.3, exceptional snow loads may be treated as accidental actions depending on geographical locations.

**NOTE:** The National Annex may give the conditions of use (which may include geographical locations) of this clause.

(4) In accordance with EN 1990:2002, 4.1.1 (2), for the particular condition defined in 1.6.10, loads due to exceptional snow drifts may be treated as accidental actions, depending on geographical locations.

**NOTE:** The National Annex may give the conditions of use (which may include geographical locations) of this clause.

### 3. Section 3 Design situations

#### 3.1. General

(1)P The relevant snow loads shall be determined for each design situation identified, in accordance with EN 1990:2002, 3.5.

(2) For local effects described in Section 6 the persistent/transient design situation should be used.

#### 3.2. Normal conditions

(1) For locations where exceptional snow falls (see 2(3)) and exceptional snow drifts (see 2(4)) are unlikely to occur, the transient/persistent design situation should be used for both the undrifted and the drifted snow load arrangements determined using 5.2(3)P a) and 5.3.

**NOTE:** See Annex A case A.

#### 3.3. Exceptional conditions

(1) For locations where exceptional snow falls (see 2(3)) may occur but not exceptional snow drifts (see 2(4)) the following applies:

- a) the transient/persistent design situation should be used for both the undrifted and the drifted snow load arrangements determined using 5.2(3)P a) and 5.3, and
- b) the accidental design situation should be used for both the undrifted and the drifted snow load arrangements determined using 4.3, 5.2(3)P (b) and 5.3.

**NOTE 1:** See Annex A case B1.

**NOTE 2:** The National Annex may define which design situation applies for a particular local effect described in Section 6.

(2) For locations where exceptional snow falls (see 2(3)) are unlikely to occur but exceptional snow drifts (see 2(4)) may occur the following applies:

- a) the transient/persistent design situation should be used for both the undrifted and the drifted snow load arrangements determined using 5.2(3)P a) and 5.3, and
- b) the accidental design situation determined using 5.2(3)P c) and Annex B.

**NOTE:** See Annex A case B2.

(3) For locations where both exceptional snow falls (see 2(3)) and exceptional snow drifts (see 2(4)) may occur the following applies:



- a) the transient/persistent design situation should be used for both the undrifted and the drifted snow load arrangements determined using 5.2(3)P a) and 5.3, and
- b) the accidental design situation should be used for both the undrifted and the drifted snow load arrangements determined using 4.3, 5.2(3)P(b) and 5.3.
- c) the accidental design situation should be used for the snow load cases determined using 5.2(3)P c) and Annex B.

**NOTE 1:** See Annex A case B3.

**NOTE 2:** The National Annex may define which design situation to apply for a particular local effect described in Section 6.

## 4. Section 4 Snow load on the ground

### 4.1. Characteristic values

(1) The characteristic value of snow load on the ground ( $s_k$ ) should be determined in accordance with EN 1990:2002, 4.1.2 (7)P and the definition for characteristic snow load on the ground given in 1.6.1.

**NOTE 1:** The National Annex specifies the characteristic values to be used. To cover unusual local conditions the National Annex may additionally allow the client and the relevant authority to agree upon a different characteristic value from that specified for an individual project.

**NOTE 2:** Annex C gives the European ground snow load map, resulting from studies commissioned by DGIII/D-3. The National Annex may make reference to this map in order to eliminate, or to reduce, inconsistencies occurring at borderlines between countries.

(2) In special cases where more refined data is needed, the characteristic value of snow load on the ground ( $s_k$ ) may be refined using an appropriate statistical analysis of long records taken in a well sheltered area near the site.

**NOTE 1:** The National Annex may give further complementary guidance.

**NOTE 2:** As there is usually considerable variability in the number of recorded maximum winter values, record periods of less than 20 years will not generally be suitable.

(3) Where in particular locations, snow load records show individual, exceptional values which cannot be treated by the usual statistical methods, the characteristic values should be determined without taking into account these exceptional values. The exceptional values may be considered outside the usual statistical methods in accordance with 4.3.

### 4.2. Other representative values

(1) According to EN1990:2002, 4.1.3 the other representative values for snow load on the roof are as follows:

- Combination value  $\psi_0 S$
- Frequent value  $\psi_1 S$
- Quasi-permanent value  $\psi_2 S$

**NOTE:** The values of  $\psi$  may be set by the National Annex of EN 1990:2002. The recommended values of the coefficients  $\psi_0$ ,  $\psi_1$  and  $\psi_2$  for buildings are dependent upon the location of the site being considered and should be taken from EN 1990:2002, Table A1.1 or Table 4.1 below, in which the information relating to snow loads is identical.

**Table 4.1 Recommended values of coefficients  $\psi_0$ ,  $\psi_1$  and  $\psi_2$  for different locations for buildings.**

| Regions  | $\psi_0$ | $\psi_1$ | $\psi_2$ |
|--|----------|----------|----------|
| Finland<br>Iceland<br>Norway<br>Sweden   | 0,70     | 0,50     | 0,20     |
| Reminder of other CEN member states, for sites located at altitude $H > 1000$ m above sea level    | 0,70     | 0,50     | 0,20     |
| Reminder of other CEN member states, for sites located at altitude $H \leq 1000$ m above sea level | 0,50     | 0,20     | 0,00     |

#### 4.3. Treatment of exceptional snow loads on the ground

(1) For locations where exceptional snow loads on the ground can occur, they may be determined by:

$$S_{Ad} = C_{esl} S_k \quad (4.1)$$

where:

$S_{Ad}$  is the design value of exceptional snow load on the ground for the given location;  
 $C_{esl}$  is the coefficient for exceptional snow loads;  
 $S_k$  is the characteristic value of snow load on the ground for a given location.

**NOTE:** The coefficient  $C_{esl}$  may be set by the National Annex. The recommended value for  $C_{esl}$  is 2,0 (see also 2(3))

## 5. Section 5 Snow load on roofs

### 5.1. Nature of the load

(1)P The design shall recognise that snow can be deposited on a roof in many different patterns.

(2) Properties of a roof or other factors causing different patterns can include:

- a) the shape of the roof;
- b) its thermal properties;

- c) the roughness of its surface;
- d) the amount of heat generated under the roof;
- e) the proximity of nearby buildings;
- f) the surrounding terrain;
- g) the local meteorological climate, in particular its windiness, temperature variations, and likelihood of precipitation (either as rain or as snow).

## 5.2. Load arrangements

(1)P The following two primary load arrangements shall be taken into account:

- undrifted snow load on roofs (see 1.6.5);
- drifted snow load on roofs (see 1.6.6).

(2) The load arrangements should be determined using 5.3; and Annex B, where specified in accordance with 3.3.

**NOTE:** The National Annex may specify the use of Annex B for the roof shapes described in 5.3.4, 5.3.6 and 6.2, and will normally apply to specific locations where all the snow usually melts and clears between the individual weather systems and where moderate to high wind speeds occur during the individual weather system.

(3)P Snow loads on roofs shall be determined as follows:

- a) for the persistent / transient design situations

$$S = \mu_i C_e C_t S_k \quad (5.1)$$

- b) for the accidental design situations where exceptional snow load is the accidental action (except for the cases covered in 5.2 (3) P c)

$$S = \mu_i C_e C_t S_{Ad} \quad (5.2)$$

**Note:** See 2(3).

- c) for the accidental design situations where exceptional snow drift is the accidental action and where Annex B applies

$$S = \mu_i S_k \quad (5.3)$$

**NOTE:** See 2(4).

where:

$\mu_i$  is the snow load shape coefficient (see Section 5.3 and Annex B)

$S_k$  is the characteristic value of snow load on the ground

$S_{Ad}$  is the design value of exceptional snow load on the ground for a given location (see 4.3)

$C_e$  is the exposure coefficient

$C_t$  is the thermal coefficient

(4) The load should be assumed to act vertically and refer to a horizontal projection of the roof area.

(5) When artificial removal or redistribution of snow on a roof is anticipated the roof should be designed for suitable load arrangements.

**NOTE 1:** Load arrangements according to this Section have been derived for natural deposition patterns only.

**NOTE 2:** Further guidance may be given in the National Annex.

(6) In regions with possible rainfalls on the snow and consecutive melting and freezing, snow loads on roofs should be increased, especially in cases where snow and ice can block the drainage system of the roof.

**NOTE:** Further complementary guidance may be given in the National Annex.

(7) The exposure coefficient  $C_e$  should be used for determining the snow load on the roof. The choice for  $C_e$  should consider the future development around the site.  $C_e$  should be taken as 1,0 unless otherwise specified for different topographies.

**NOTE:** The National Annex may give the values of  $C_e$  for different topographies. The recommended values are given in Table 5.1 below.

Table 5.1 Recommended values of  $C_e$  for different topographies

| Topography             | $C_e$ |
|------------------------|-------|
| Windswept <sup>a</sup> | 0,8   |
| Normal <sup>b</sup>    | 1,0   |
| Sheltered <sup>c</sup> | 1,2   |

<sup>a</sup> *Windswept topography*: flat unobstructed areas exposed on all sides without, or little shelter afforded by terrain, higher construction works or trees.

<sup>b</sup> *Normal topography*: areas where there is no significant removal of snow by wind on construction work, because of terrain, other construction works or trees.

<sup>c</sup> *Sheltered topography*: areas in which the construction work being considered is considerably lower than the surrounding terrain or surrounded by high trees and/or surrounded by higher construction works.

(8) The thermal coefficient  $C_t$  should be used to account for the reduction of snow loads on roofs with high thermal transmittance ( $> 1 \text{ W/m}^2\text{K}$ ), in particular for some glass covered roofs, because of melting caused by heat loss.

For all other cases:

$$C_t = 1,0$$

**NOTE 1:** Based on the thermal insulating properties of the material and the shape of the construction work, the use of a reduced  $C_t$  value may be permitted through the National Annex.

**NOTE 2:** Further guidance may be obtained from ISO 4355.

### 5.3. Roof shape coefficients

#### 5.3.1. General

(1) 5.3 gives roof shape coefficients for undrifted and drifted snow load arrangements for all types of roofs identified in this standard, with the exception of the consideration of exceptional snow drifts defined in Annex B, where its use is allowed.

(2) Special consideration should be given to the snow load shape coefficients to be used where the roof has an external geometry which may lead to increases in snow load, that are considered significant in comparison with that of a roof with linear profile.

(3) Shape coefficients for roof shapes in 5.3.2, 5.3.3 and 5.3.4 are given in Figure 5.1.

### 5.3.2. Monopitch roofs

(1) The snow load shape coefficient  $\mu_1$  that should be used for monopitch roofs is given in Table 5.2 and shown in Figure 5.1 and Figure 5.2.

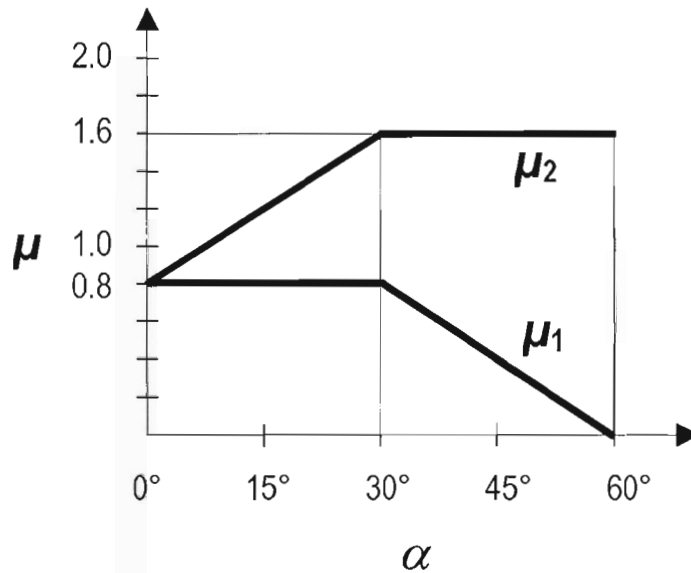

Figure 5.1: Snow load shape coefficients

(2) The values given in Table 5.2 apply when the snow is not prevented from sliding off the roof. Where snow fences or other obstructions exist or where the lower edge of the roof is terminated with a parapet, then the snow load shape coefficient should not be reduced below 0,8.

Table 5.2: Snow load shape coefficients

| Angle of pitch of roof $\alpha$ | $0^\circ \leq \alpha \leq 30^\circ$ | $30^\circ < \alpha < 60^\circ$ | $\alpha \geq 60^\circ$ |
|---------------------------------|-------------------------------------|--------------------------------|------------------------|
| $\mu_1$                         | 0,8                                 | $0,8(60 - \alpha)/30$          | 0,0                    |
| $\mu_2$                         | $0,8 + 0,8 \alpha/30$               | 1,6                            | --                     |

(3) The load arrangement of Figure 5.2 should be used for both the undrifted and drifted load arrangements.

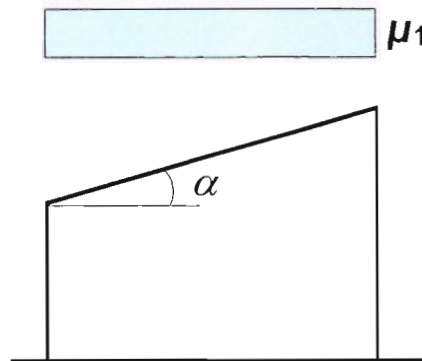

**Figure 5.2: Snow load shape coefficient - monopitch roof**

### 5.3.3. Pitched roofs

(1) The snow load shape coefficients that should be used for pitched roofs are given in Figure 5.3, where  $\mu_1$  is given in Table 5.2 and shown in Figure 5.1.

(2) The values given in Table 5.2 apply when snow is not prevented from sliding off the roof. Where snow fences or other obstructions exist or where the lower edge of the roof is terminated with a parapet, then the snow load shape coefficient should not be reduced below 0,8.



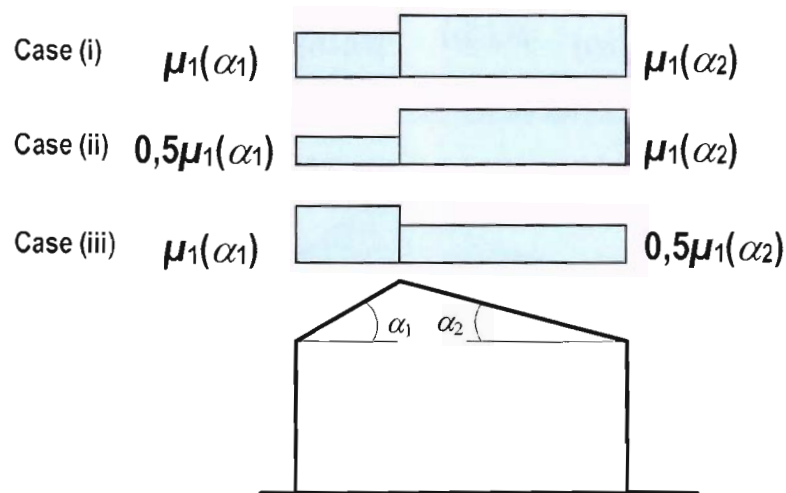

**Figure 5.3: Snow load shape coefficients - pitched roofs**

(3) The undrifted load arrangement which should be used is shown in Figure 5.3, case (i).

(4) The drifted load arrangements which should be used are shown in Figure 5.3, cases (ii) and (iii), unless  $\square_{AC_1}$  otherwise  $\langle AC_1 \rangle$  specified for local conditions.

**NOTE:** Based on local conditions, an alternative drifting load arrangement may be given in the National Annex.

#### 5.3.4. Multi-span roofs

(1) For multi-span roofs the snow load shape coefficients are given in Table 5.2 and shown in Figure  $\square_{AC_1}$  5.4  $\langle AC_1 \rangle$ .

(2) The undrifted load arrangement which should be used is shown in Figure 5.4, case (i).

(3) The drifted load arrangement which should be used is shown in Figure 5.4, case (ii), unless specified for local conditions.

**NOTE:** Where permitted by the National Annex, Annex B may be used to determine the load case due to drifting.

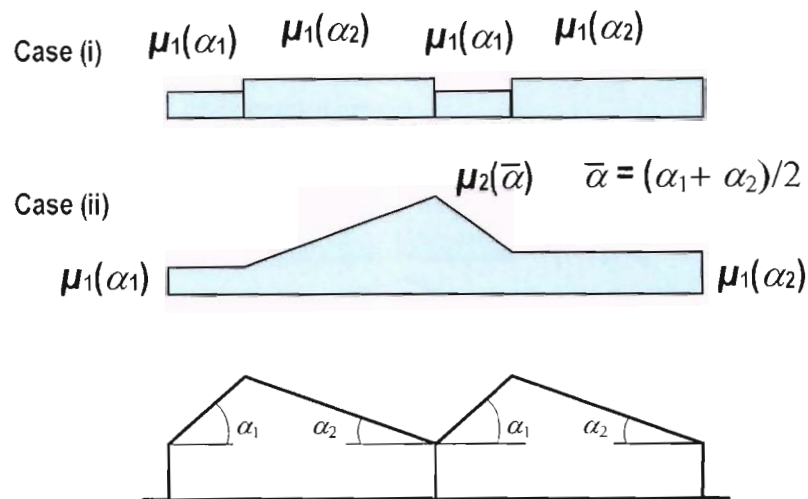

Figure 5.4: Snow load shape coefficients for multi-span roofs

(4) Special consideration should be given to the snow load shape coefficients for the design of multi-span roofs, where one or both sides of the valley have a slope greater than  $60^\circ$ .

**NOTE:** Guidance may be given in the National Annex.

### 5.3.5. Cylindrical roofs

(1) The snow load shape coefficients that should be used for cylindrical roofs, in absence of snow fences, are given in the following expressions (see also Figure 5.6).

$$\text{For } \beta > 60^\circ, \quad \mu_3 = 0 \quad (5.4)$$

$$\text{For } \beta \leq 60^\circ, \quad \mu_3 = 0,2 + 10 h/b \quad (5.5)$$

An upper value of  $\mu_3$  should be specified.

**NOTE 1:** The upper value of  $\mu_3$  may be specified in the National Annex. The recommended upper value for  $\mu_3$  is 2,0 (see Figure 5.5).

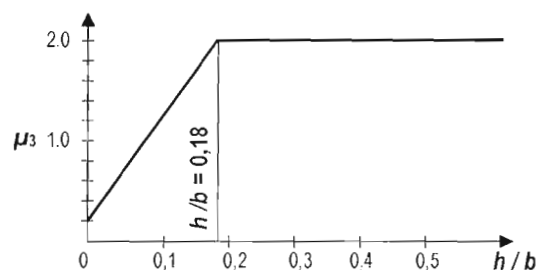

Figure 5.5: Recommended snow load shape coefficient for cylindrical roofs of differing rise to span ratios (for  $\beta \leq 60^\circ$ )

**NOTE 2:** Rules for considering the effect of snow fences for snow loads on cylindrical roofs may be given in the National Annex.

(2) The undrifted load arrangement which should be used is shown in Figure 5.6, case (i).

(3) The drifted load arrangement which should be used is shown in Figure 5.6, case (ii), unless specified for local conditions.

**NOTE:** Based on local conditions an alternative drifting load arrangement may be given in the National Annex.

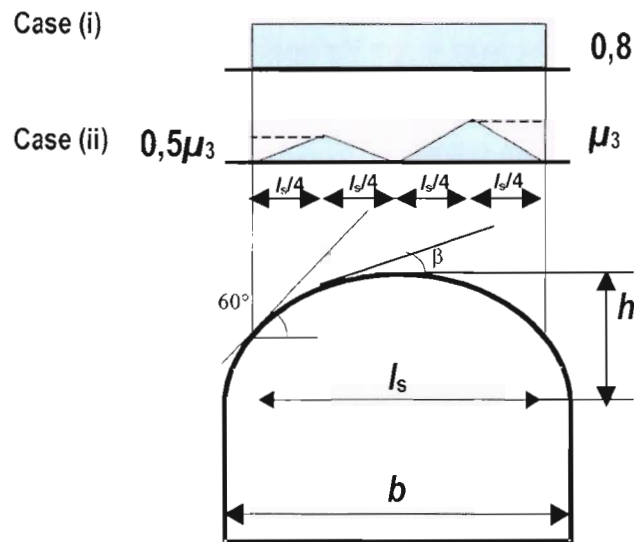

**Figure 5.6: Snow load shape coefficients for cylindrical roof**

### 5.3.6. Roof abutting and close to taller construction works

(1) The snow load shape coefficients that should be used for roofs abutting to taller construction works are given in the following expressions and shown in Figure 5.7.

$$\mu_1 = 0,8 \text{ (assuming the lower roof is flat)} \quad (5.6)$$

$$\mu_2 = \mu_S + \mu_W \quad (5.7)$$

where:

$\mu_S$  is the snow load shape coefficient due to sliding of snow from the upper roof

For  $\alpha \leq 15^\circ$ ,  $\mu_S = 0$ ,

For  $\alpha > 15^\circ$ ,  $\mu_s$  is determined from an additional load amounting to 50 % of the maximum total snow load, on the adjacent slope of the upper roof calculated according to 5.3.3

$\mu_w$  is the snow load shape coefficient due to wind

$$\mu_w = (b_1 + b_2)/2h \leq \gamma h/s_k, \quad (5.8)$$

where:

$\gamma$  is the weight density of snow, which for this calculation may be taken as  $2 \text{ kN/m}^3$

An upper and a lower value of  $\mu_w$  should be specified.

**NOTE 1:** The range for  $\mu_w$  may be fixed in the National Annex. The recommended range is  $0,8 \leq \mu_w \leq 4$ .

The drift length is determined as follows:

$$l_s = 2h \quad (5.9)$$

**NOTE 2:** A restriction for  $l_s$  may be given in the National Annex. The recommended restriction is  $5 \leq l_s \leq 15 \text{ m}$

**NOTE 3:** If  $b_2 < l_s$  the coefficient at the end of the lower roof is determined by interpolation between  $\mu_1$  and  $\mu_2$  truncated at the end of the lower roof (see Figure 5.7).

(2) The undrifted load arrangement which should be used is shown in Figure 5.7, case (i).

(3) The drifted load arrangement which should be used is shown in Figure 5.7, case (ii), unless specified for local conditions.

**NOTE:** Where permitted by the National Annex, Annex B may be used to determine the load case due to drifting.

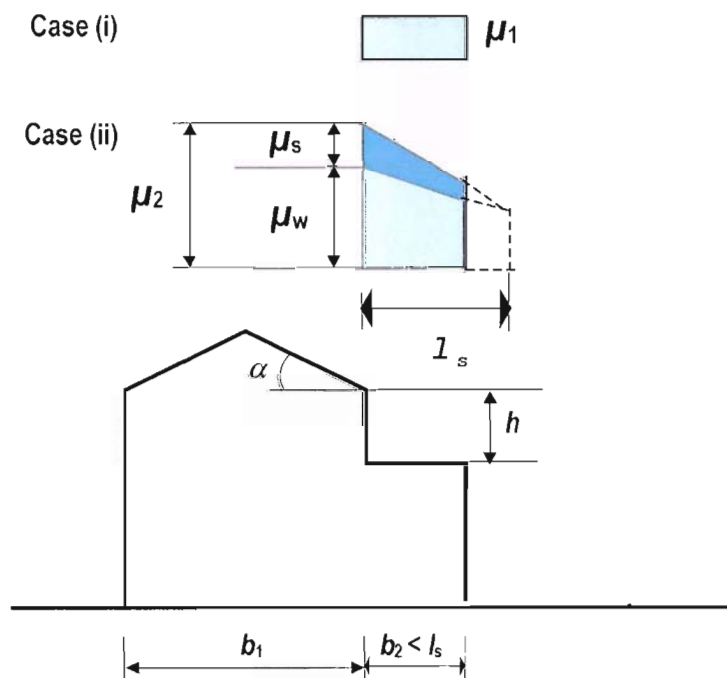
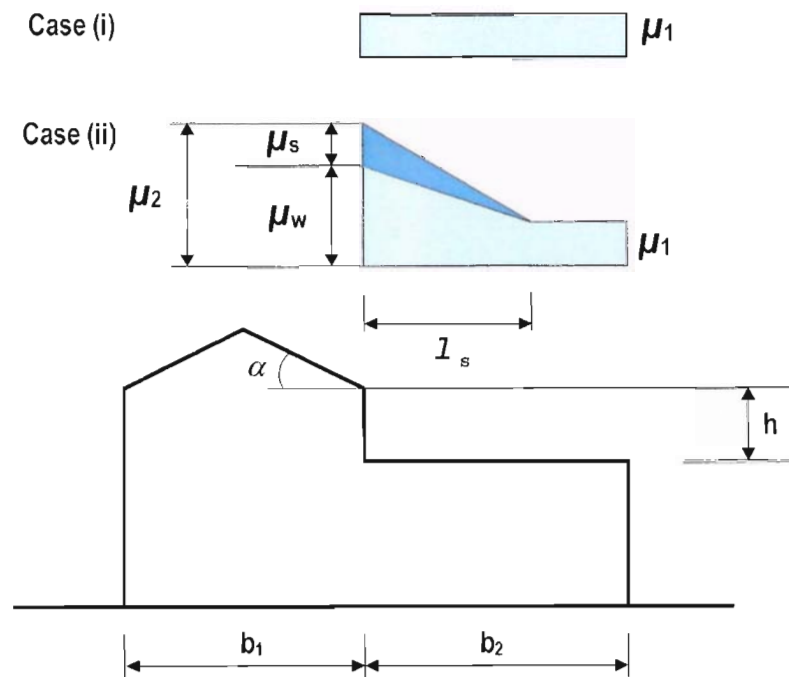

$\langle AC_1 \rangle$  This load arrangement applies where  $b_2 < l_s$   $\langle AC_1 \rangle$

Figure 5.7: Snow load shape coefficients for roofs abutting to taller construction works

## 6. Section 6 Local effects

### 6.1. General

(1) This section gives forces to be applied for the local verifications of:

- drifting at projections and obstructions;
- the edge of the roof;
- snow fences.

(2) The design situations to be considered are persistent/transient.

### 6.2. Drifting at projections and obstructions

(1) In windy conditions drifting of snow can occur on any roof which has obstructions as these cause areas of aerodynamic shade in which snow accumulates.

(2) The snow load shape coefficients and drift lengths for quasi-horizontal roofs should be taken as follows (see Figure 6.1), unless specified for local conditions:

$$\mu_1 = 0,8 \quad \mu_2 = \gamma h/s_k \quad (6.1)$$

with the restriction:  $0,8 \leq \mu_2 \leq 2,0$  (6.2)

where:

$\gamma$  is the weight density of snow, which for this calculation may be taken as  $2 \text{ kN/m}^3$

$$l_s = 2h \quad (6.3)$$

with the restriction:  $5 \leq l_s \leq 15 \text{ m}$

**NOTE:** Where permitted by the National Annex, Annex B may be used to determine the load case due to drifting.

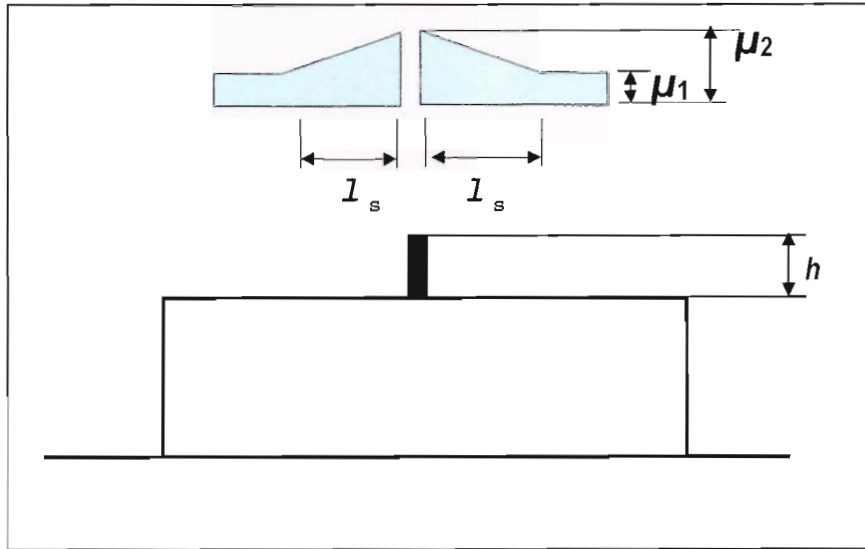

**Figure 6.1: Snow load shape coefficients at projections and obstructions**

### 6.3. Snow overhanging the edge of a roof

(1) Snow overhanging the edge of a roof should be considered.

**NOTE:** The National Annex may specify the conditions of use for this clause. It is recommended that the clause is used for sites above 800 meters above sea level.

(2) The design of those parts of a roof cantilevered out beyond the walls should take account of snow overhanging the edge of the roof, in addition to the load on that part of the roof. The loads due to the overhang may be assumed to act at the edge of the roof and may be calculated as follows:

$$s_e = k s^2 / \gamma \quad (6.4)$$

where:

$s_e$  is snow load per metre length due to the overhang (see Figure 6.2)

$s$  is the most onerous undrifted load case appropriate for the roof under consideration (see 5.2)

$\gamma$  is the weight density of snow which for this calculation may be taken as  $3 \text{ kN/m}^3$

$k$  is a coefficient to take account of the irregular shape of the snow

**NOTE:** The values of  $k$  may be given in the National Annex. The recommended way for calculating  $k$  is as follows:  $k = 3/d$ , but  $k \leq d \gamma$ . Where  $d$  is the depth of the snow layer on the roof in meters (see Figure 6.2)

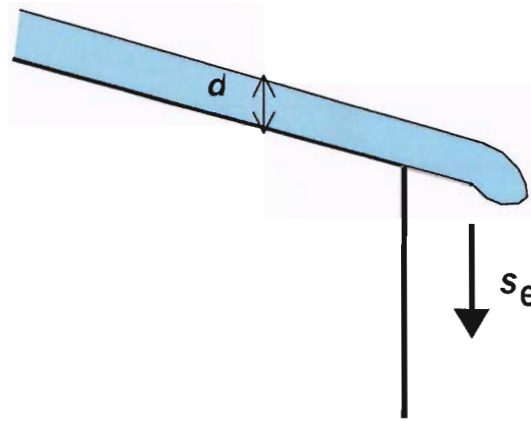

**Figure 6.2** Snow overhanging the edge of a roof

#### 6.4. Snow loads on snowguards and other obstacles

(1) Under certain conditions snow may slide down a pitched or curved roof. The coefficient of friction between the snow and the roof should be assumed to be zero. For this calculation the force  $F_s$  exerted by a sliding mass of snow, in the direction of slide, per unit length of the building should be taken as:

$$F_s = s b \sin \alpha \quad (6.5)$$

where:

$s$  is the snow load on the roof relative to the most onerous undrifted load case appropriate for roof area from which snow could slide (see 5.2 and 5.3)

$b$  is the width on plan (horizontal) from the guard or obstacle to the next guard or to the ridge

$\alpha$  pitch of the roof, measured from the horizontal



## **ANNEX A (normative)**

### **Design situations and load arrangements to be used for different locations**

(1) Table A.1 summarises four cases A, B1, B2 and B3 (see 3.2, 3.3(1), 3.3(2) and 3.3(3) respectively) identifying the design situations and load arrangements to be used for each individual case.

**Table A.1 Design Situations and load arrangements to be used for different locations**

| Normal  | Exceptional conditions   |  |  |
|---|--|--|--|
| Case A  | Case B1  | Case B2  | Case B3  |
| No exceptional falls<br>No exceptional drift  | Exceptional falls<br>No exceptional drift                                | No exceptional falls<br>Exceptional drift                                | Exceptional falls<br>Exceptional drift                                   |
| 3.2(1)  | 3.3(1)   | 3.3(2)   | 3.3(3)   |
| <i>Persistent/transient design situation</i>  | <i>Persistent/transient design situation</i>                             | <i>Persistent/transient design situation</i>                             | <i>Persistent/transient design situation</i>                             |
| [1] undrifted $\mu_i C_e C_t s_k$   | [1] undrifted $\mu_i C_e C_t s_k$  | [1] undrifted $\mu_i C_e C_t s_k$  | [1] undrifted $\mu_i C_e C_t s_k$  |
| [2] drifted $\mu_i C_e C_t s_k$   | [2] drifted $\mu_i C_e C_t s_k$  | [2] drifted $\mu_i C_e C_t s_k$ (except for roof shapes in AnnexB)       | [2] drifted $\mu_i C_e C_t s_k$ (except for roof shapes in AnnexB)       |
|   | <i>Accidental design situation (where snow is the accidental action)</i> | <i>Accidental design situation (where snow is the accidental action)</i> | <i>Accidental design situation (where snow is the accidental action)</i> |
|   | [3] undrifted $\mu_i C_e C_t C_{esi} s_k$                                | [3] drifted $\mu_i s_k$ (for roof shapes in AnnexB)                      | [3] undrifted $\mu_i C_e C_t C_{esi} s_k$                                |
|   | [4] drifted $\mu_i C_e C_t C_{esi} s_k$                                  |  | [4] drifted $\mu_i s_k$ (for roof shapes in AnnexB)                      |
| <b>NOTE 1:</b> Exceptional conditions are defined according to the National Annex.  |  |  |  |
| <b>NOTE 2:</b> For cases B1 and B3 the National Annex may define design situations which apply for the particular local effects described in section 6. |  |  |  |

## ANNEX B (normative)

### Snow load shape coefficients for exceptional snow drifts

#### B1 Scope

(1) This annex gives snow shape coefficients to determine load arrangements due to exceptional snow drifts for the following types of roofs.

- a) Multi-span roofs;
- b) Roofs abutting and close to taller construction works;
- c) Roofs where drifting occurs at projections, obstructions and parapets;
- d) For all other load arrangements Section 5 and Section 6 should be used as appropriate.

(2) When considering load cases using snow load shape coefficients obtained from this Annex it should be assumed that they are exceptional snow drift loads and that there is no snow elsewhere on the roof.

(3) In some circumstances more than one drift load case may be applicable for the same location on a roof in which case they should be treated as alternatives.

#### B2 Multi-span roofs

(1) The snow load shape coefficient for an exceptional snow drift that should be used for valleys of multi-span roofs is given in Figure B1 and B2(2).

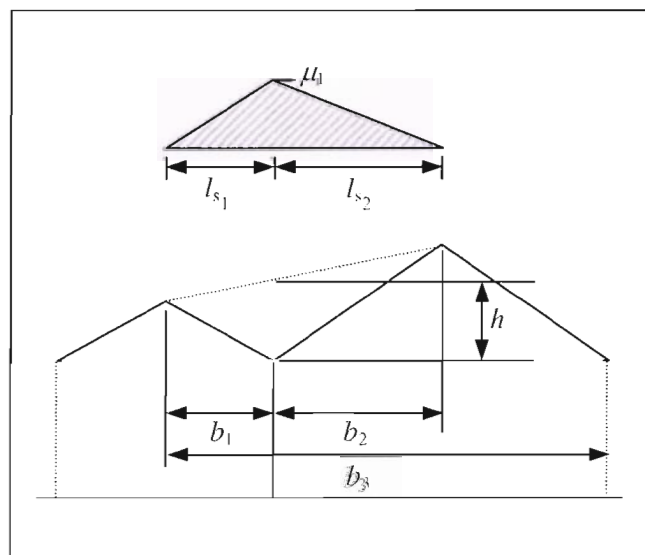

Figure B1: Shape coefficient and drift lengths for exceptional snow drifts – valleys of multi-span roofs

(2) The shape coefficient given in Figure B1 is determined as the least value of:

$$\mu_1 = 2h/s_k$$

$$\mu_1 = 2b_3/(l_{s_1} + l_{s_2})$$

$$\mu_1 = 5$$

The drift lengths are determined as:

$$l_{s_1} = b_1, \quad l_{s_2} = b_2$$

(3) For roofs of more than two spans with approximately symmetrical and uniform geometry,  $b_3$  should be taken as the horizontal dimension of three slopes (i.e. span x 1.5) and this snow load distribution should be considered applicable to every valley, although not necessarily simultaneously.

(4) Care should be taken when selecting  $b_3$  for roofs with non-uniform geometry, significant differences in ridge height and/or span may act as obstructions to the free movement of snow across the roof and influence the amount of snow theoretically available to form the drift.

(5) Where simultaneous drifts in several valleys of a multi-span roof are being considered in the design of a structure as a whole, a maximum limit on the amount of drifted snow on the roof should be applied. The total snow load per metre width in all the simultaneous drifts should not exceed the product of the ground snow load and the length of the building perpendicular to the valley ridges.

**NOTE:** If the structure is susceptible to asymmetric loading, the design should also consider the possibility of drifts of differing severity in the valleys.

### **B3 Roofs abutting and close to taller structures**

(1) The snow load shape coefficients for exceptional snow drifts that should be used for roofs abutting a taller construction work are given in Figure B2 and Table B1.

(2) The snow load case given in Figure B2 is also applicable for roofs close to, but not abutting, taller buildings, with the exception that it is only necessary to consider the load actually on the lower roof, i.e. the load implied between the two buildings can be ignored.

**NOTE:** The effect of structures close to, but not abutting the lower roof will depend on the roof areas available from which snow can be blown into the drift and the difference in levels. However, as an approximate rule, it is only necessary to consider nearby structures when they are less than 1,5m away.

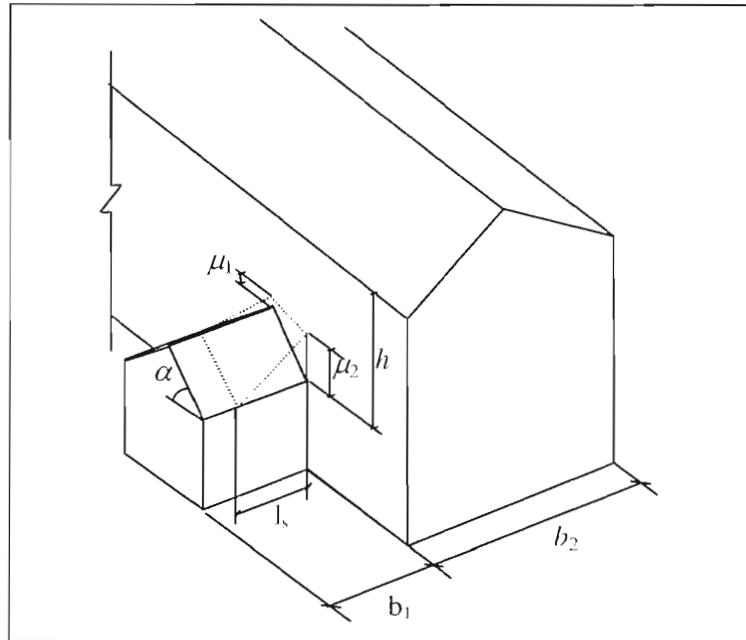

**Figure B2: Shape coefficients and drift lengths for exceptional snow drifts - Roofs abutting and close to taller structures**

(3) The drift length  $l_s$  is the least value of  $5h$ ,  $b_1$  or  $15\text{m}$ .

**Table B1 : Shape coefficients for exceptional snow drifts for roofs abutting and close to taller structures**

| Shape coefficient | Angle of roof pitch $\alpha_1$      |                                   |                                  |                        |
|-------------------|-------------------------------------|-----------------------------------|----------------------------------|------------------------|
|                   | $0^\circ \leq \alpha \leq 15^\circ$ | $15^\circ < \alpha \leq 30^\circ$ | $30^\circ < \alpha < 60^\circ$   | $60^\circ \leq \alpha$ |
| $\mu_1$           | $\mu_3$                             | $\mu_3 \{ [30 - \alpha] / 15 \}$  | 0                                | 0                      |
| $\mu_2$           | $\mu_3$                             | $\mu_3$                           | $\mu_3 \{ [60 - \alpha] / 30 \}$ | 0                      |

**Note 1:**  $\mu_3$  is the least value of  $2h/s_K$ ,  $2b/l_s$  or 8. Where  $b$  is the larger of  $b_1$  or  $b_2$  and  $l_s$  is the least value of  $5h$ ,  $b_1$  or  $15\text{m}$ .

#### **B4 Roofs where drifting occurs at projections, obstructions and parapets**

(1) The snow load shape coefficients for exceptional snow drifts that should be used for roofs where drifting occurs at projections and obstructions, other than parapets, are given in B4(2) and Figure B3. Shape coefficients for drifting behind parapets are given in B4(4).

(2) a) If the vertical elevation against which a drift could form is not greater than  $1\text{m}$ , the effect of drifting can be ignored.

b) This clause applies to:

- Drifting against obstructions not exceeding 1m in height.

- Drifting on canopies, projecting not more than 5m from the face of the building over doors and loading bays, irrespective of the height of the obstruction.
- Slender obstructions over 1m high but not more than 2m wide, may be considered as local projections. For this specific case  $h$  may be taken as the lesser of the projection height or width perpendicular to the direction of the wind.

c) The shape coefficient given in Figure B3 is determined as the least value of:

$$\mu_1 = 2h_1/s_k \text{ or } 5$$

$$\mu_2 = 2h_2/s_k \text{ or } 5$$

In addition, for door canopies projecting not more than 5m from the building,  $\mu_1$  should not exceed  $2b/l_{s1}$ , where  $b$  is the larger of  $b_1$  and  $b_2$ .

d) The drift length ( $l_{s_i}$ ) is taken as the least value of  $5h$  or  $b_i$ , where  $i = 1$  or  $2$  and  $h \leq 1\text{m}$ .

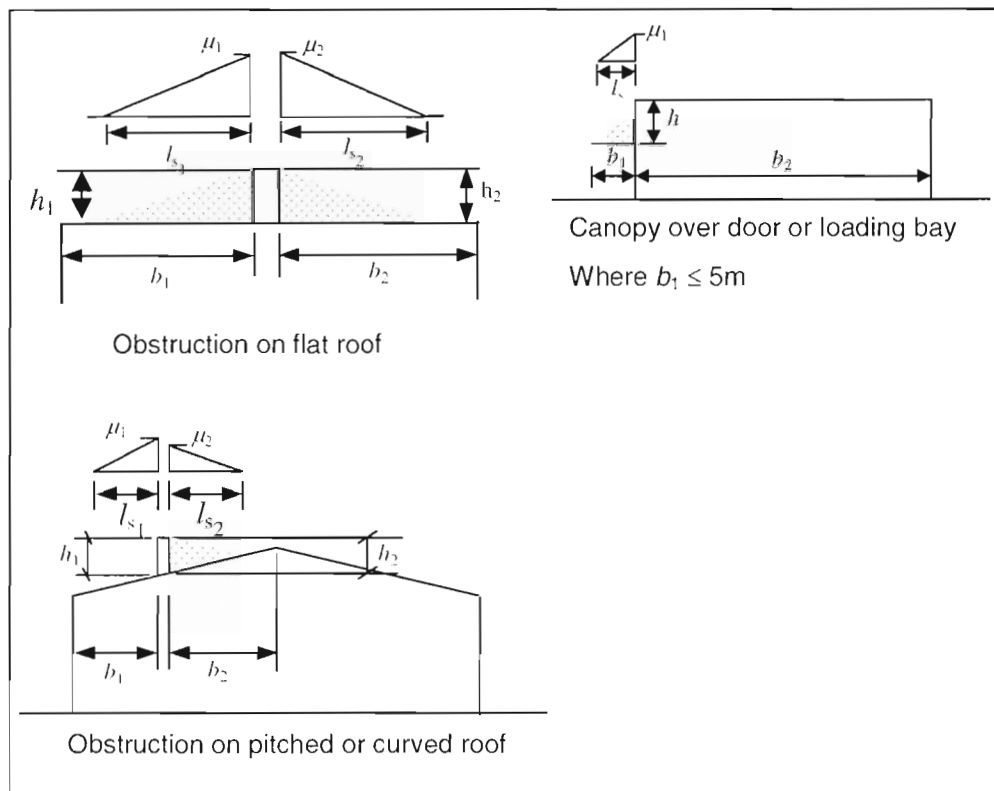

**Figure B3: Shape coefficients for exceptional snow drifts for roofs where drifting occurs at projections and obstructions**

(3) The snow load shape coefficients for exceptional snow drifts that should be used for roofs where drifting occurs at parapets are given in Figure B4.

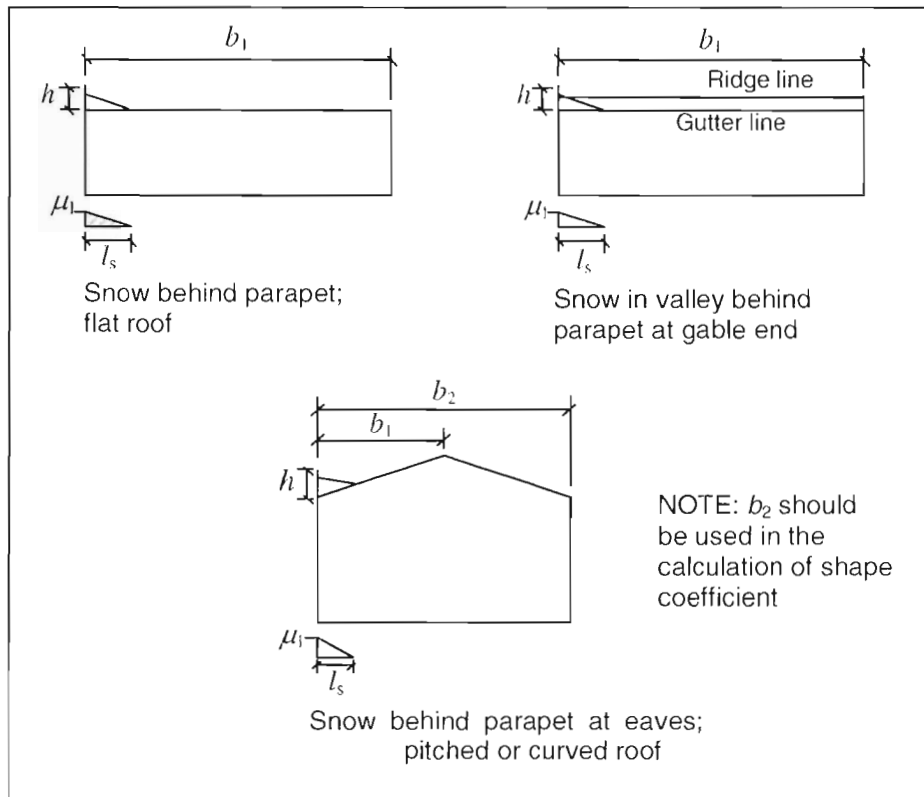

**Figure B4 : Shape coefficients for exceptional snow drifts - roofs where drifting occurs at parapets**

(4) The shape coefficient given in Figure B4 is determined as the least value of:

$$\mu_1 = 2h/s_k,$$

$$\mu_1 = 2b/l_s \quad \text{where } b \text{ is the larger of } b_1 \text{ or } b_2$$

$$\mu_1 = 8$$

The drift length  $l_s$  should be taken as the least value of  $5h$ ,  $b_1$  or 15m.

(5) For drifting in a valley behind a parapet at a gable end the snow load at the face of the parapet should be assumed to decrease linearly from its maximum value in the valley to zero at the adjacent ridges, providing the parapet does not project more than 300mm above the ridge.

## ANNEX C (informative)

### European Ground Snow Load Maps

(1) This Annex presents the European snow maps which are the result of scientific work carried out under contract to DGIII/D-3<sup>5</sup> of the European Commission, by a specifically formed research Group.

**NOTE:** The snow maps supplied by CEN members who were not directly part of the Research Group have been included in this Annex in clauses C(5) Czech Republic, C(6) Iceland and C(7) Poland.

(2) The objectives of this Annex, defined in 1.1(5), are:

- to help National Competent Authorities to redraft their national maps;
- to establish harmonised procedures to produce the maps.

This will eliminate or reduce the inconsistencies of snow load values in CEN member states and at borderlines between countries.

(3) The European AC<sub>1</sub> snow map AC<sub>1</sub> developed by the Research Group are divided into 9 different homogeneous climatic regions, as shown in Figures C.1 to C.10.

(4) In each climatic region a given load-altitude correlation formula applies and this is given in Table C.1.

Different zones are defined for each climatic region. Each zone is given a Zone number Z, which is used in the load altitude correction formula.

Among the research Group members only for Norway the map gives directly snow load on the ground at different locations.

The characteristic values of ground snow loads given are referred to mean recurrence interval (MRI) equal to 50 years.

(5) Figure C.11 shows the map supplied by the Czech National Authority.

(6) Figure C.12 shows the map supplied by the Icelandic National Authority.

---

<sup>5</sup> Results are included in the following documents, both of them are available at the Commission of the European Communities DG III - D-3 Industry, Rue de la Loi, 200 B - 1049 Brussels, or at the Università degli Studi di Pisa Dipartimento di Ingegneria Strutturale, Via Diotisalvi, 2, 56100 Pisa (IT).

1. Phase 1 Final Report to the European Commission, Scientific Support Activity in the Field of Structural Stability of Civil Engineering Works: Snow Loads, Department of Structural Engineering, University of Pisa, March 1998.

2. Phase 2 Final Report to the European Commission, Scientific Support Activity in the Field of Structural Stability of Civil Engineering Works: Snow Loads, Department of Structural Engineering, University of Pisa, September 1999.



(7) Figure C.13 shows the map supplied by the Polish National Authority.

Figure C.1. European Climatic regions

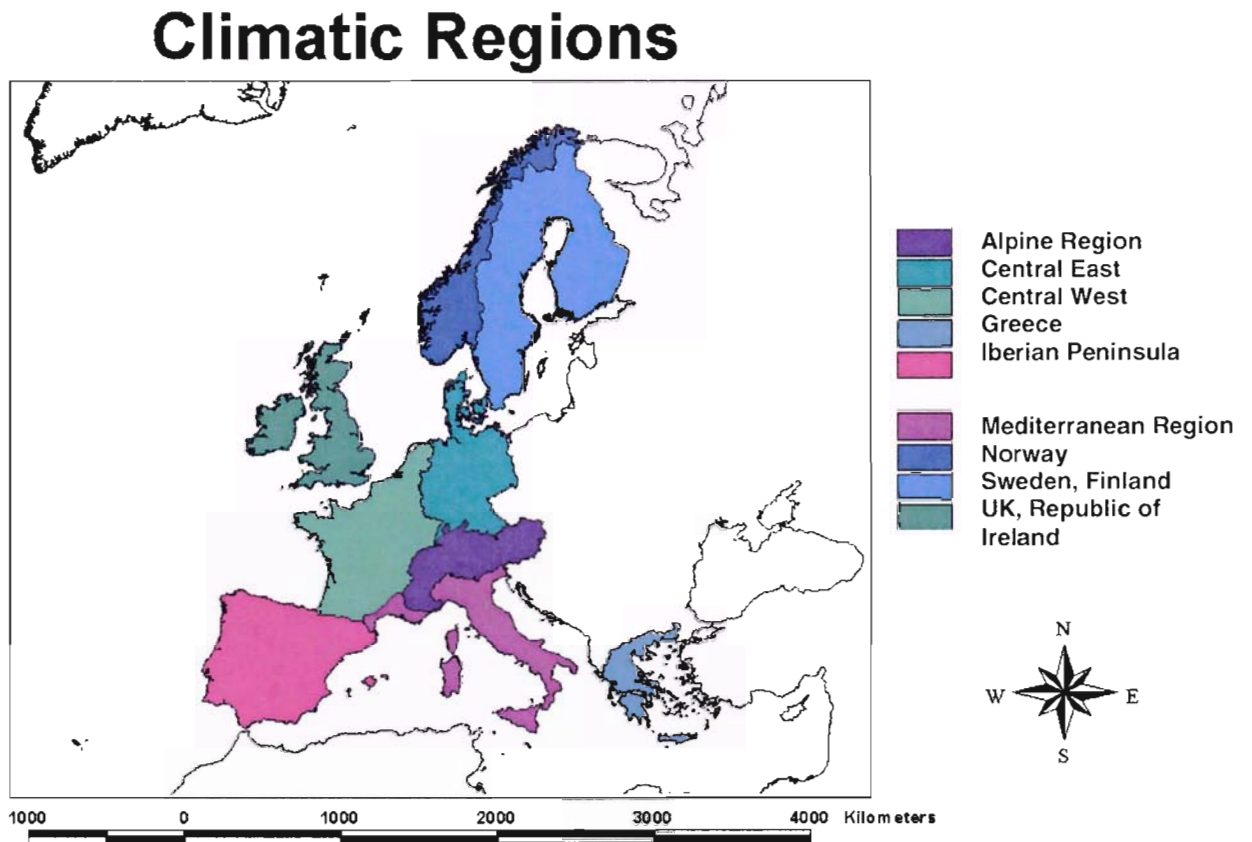

**Table C.1. Altitude - Snow Load Relationships**

| <i>Climatic Region</i>  | <i>Expression</i>  |
|-------------------------|--|
| Alpine Region           | $s_k = (0,642Z + 0,009) \left[ 1 + \left( \frac{A}{728} \right)^2 \right]$ |
| Central East            | $s_k = (0,264Z - 0,002) \left[ 1 + \left( \frac{A}{256} \right)^2 \right]$ |
| Greece                  | $s_k = (0,420Z - 0,030) \left[ 1 + \left( \frac{A}{917} \right)^2 \right]$ |
| Iberian Peninsula       | $s_k = (0,190Z - 0,095) \left[ 1 + \left( \frac{A}{524} \right)^2 \right]$ |
| Mediterranean Region    | $s_k = (0,498Z - 0,209) \left[ 1 + \left( \frac{A}{452} \right)^2 \right]$ |
| Central West            | $s_k = 0,164Z - 0,082 + \frac{A}{966}$                                     |
| Sweden, Finland         | $s_k = 0,790Z + 0,375 + \frac{A}{336}$                                     |
| UK, Republic of Ireland | $s_k = 0,140Z - 0,1 + \frac{A}{501}$                                       |

$s_k$  is the characteristic snow load on the ground [kN/m<sup>2</sup>]  
 $A$  is the site altitude above Sea Level [m]  
 $Z$  is the zone number given on the map.

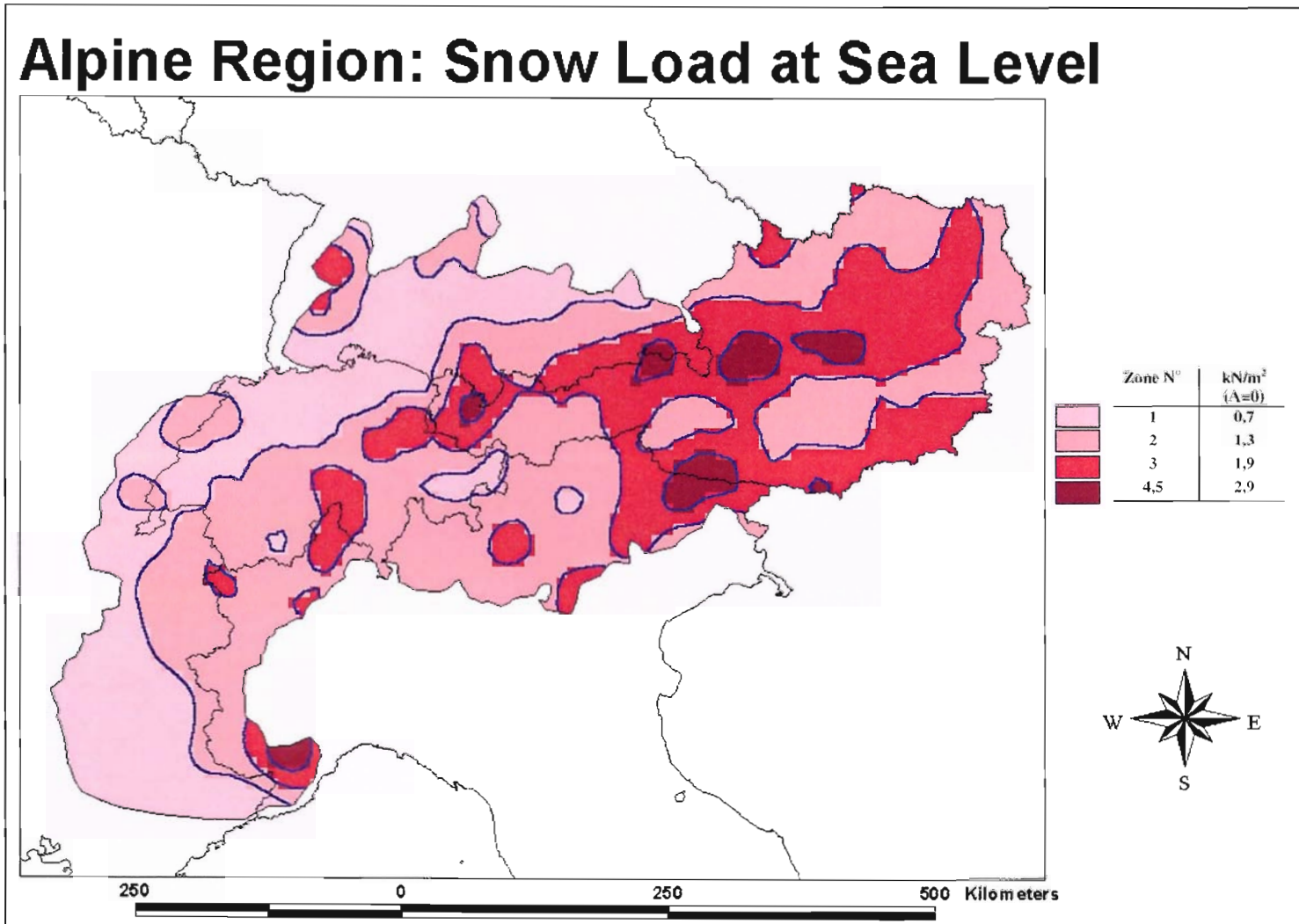

Figure C.2

# Central East: Snow Load at Sea Level

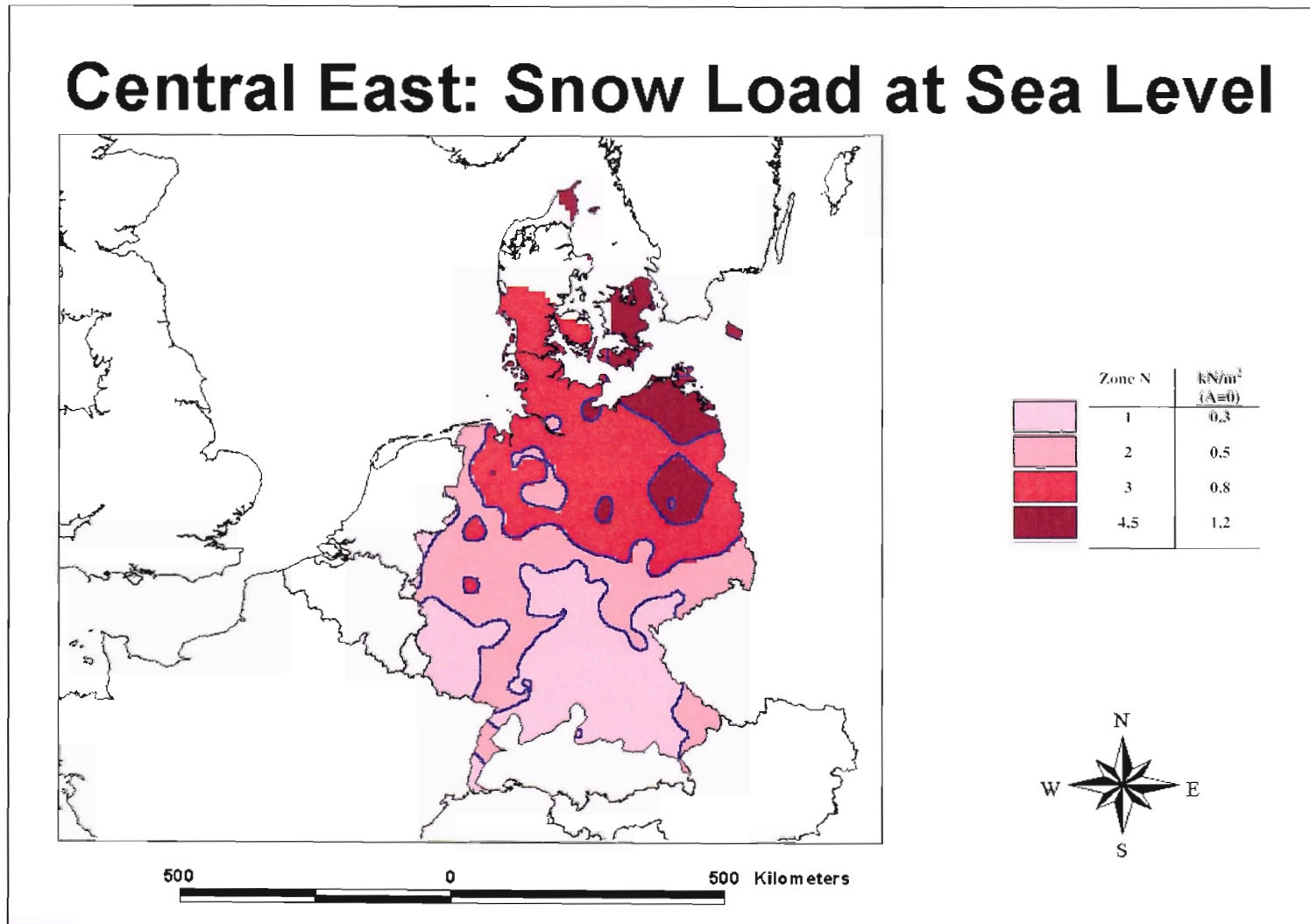

Figure C.3

# Greece: Snow Load at Sea Level

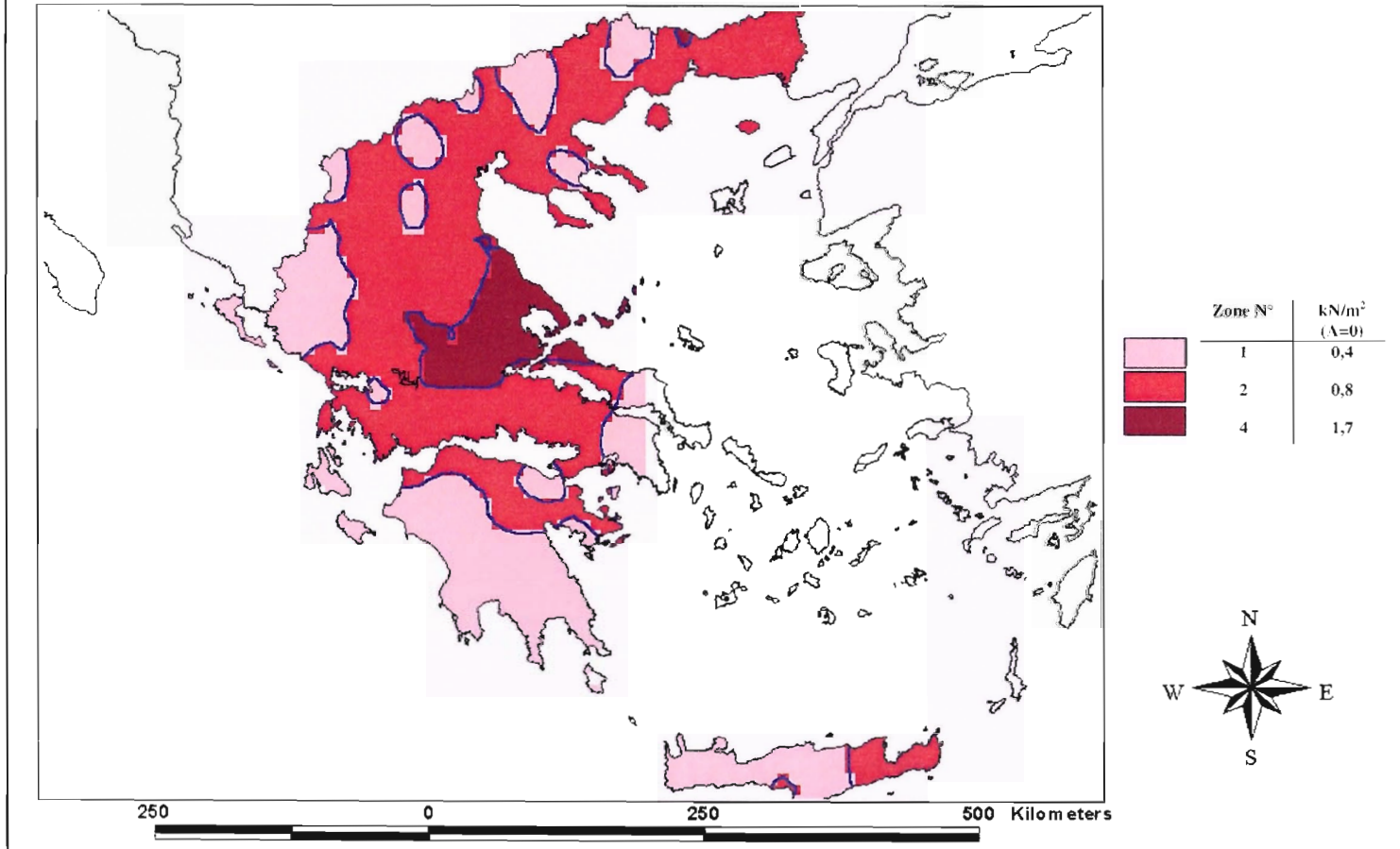

Figure C.4

## Iberian Peninsula: Snow Load at Sea Level

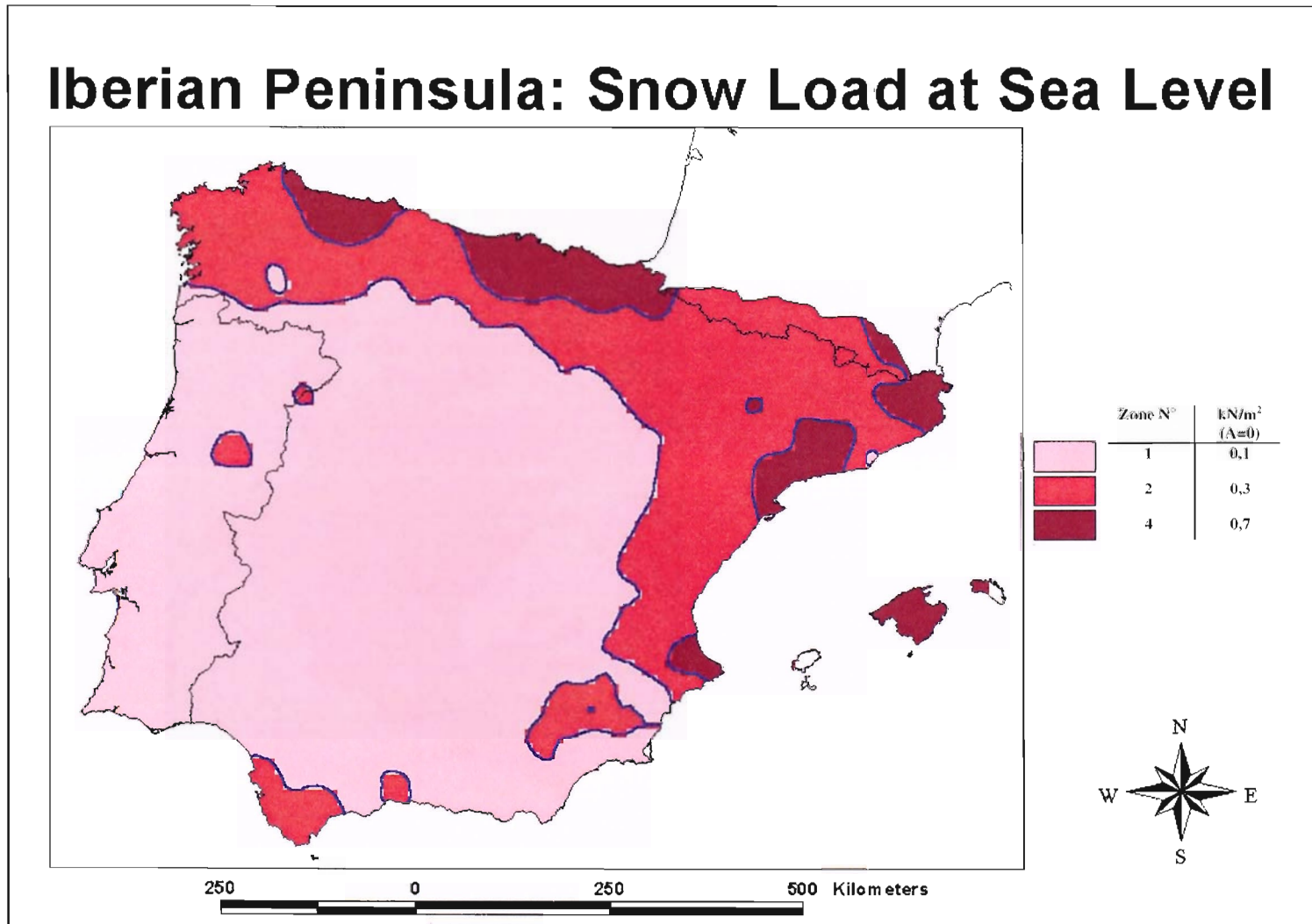

Figure C.5

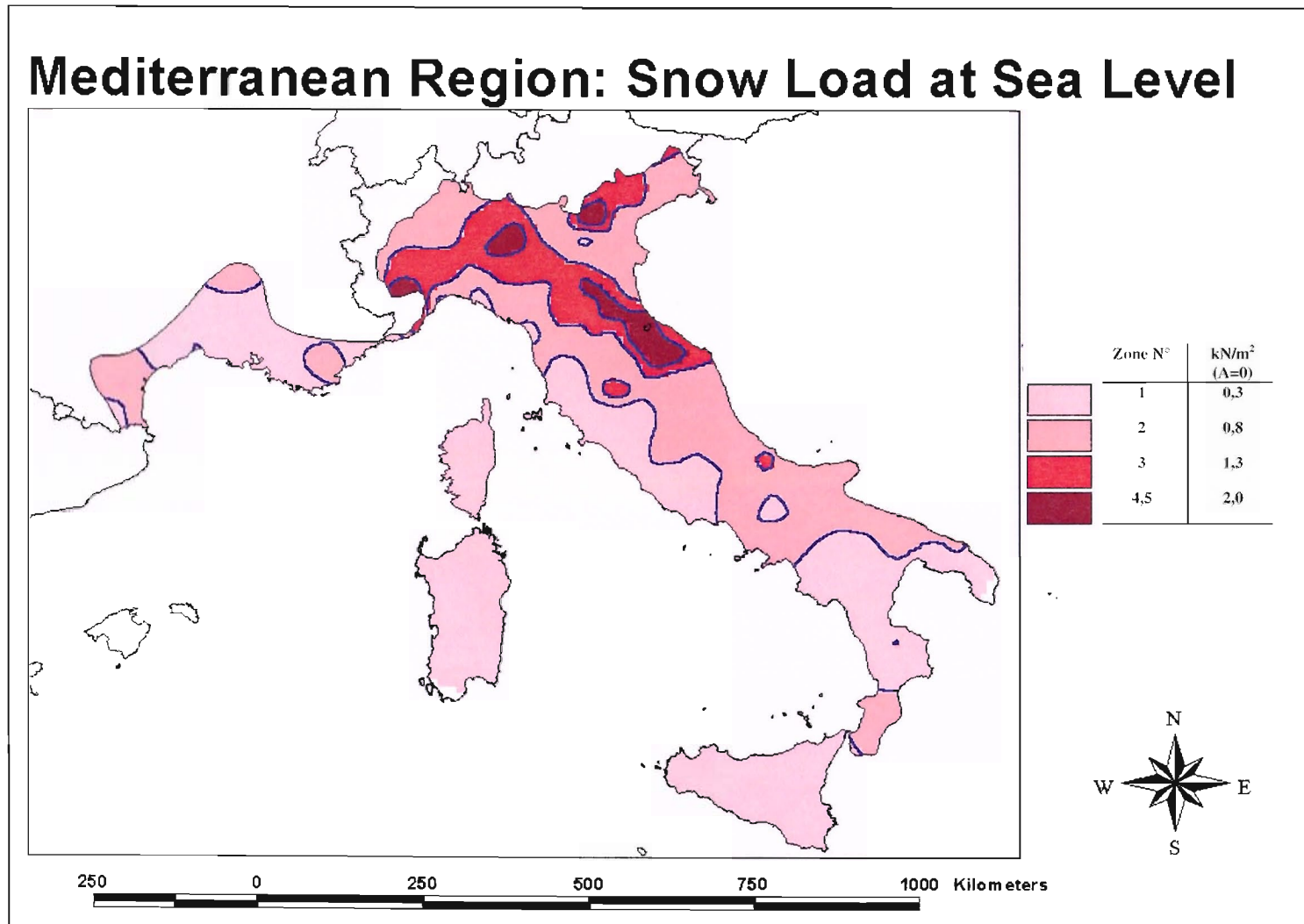

Figure C.6

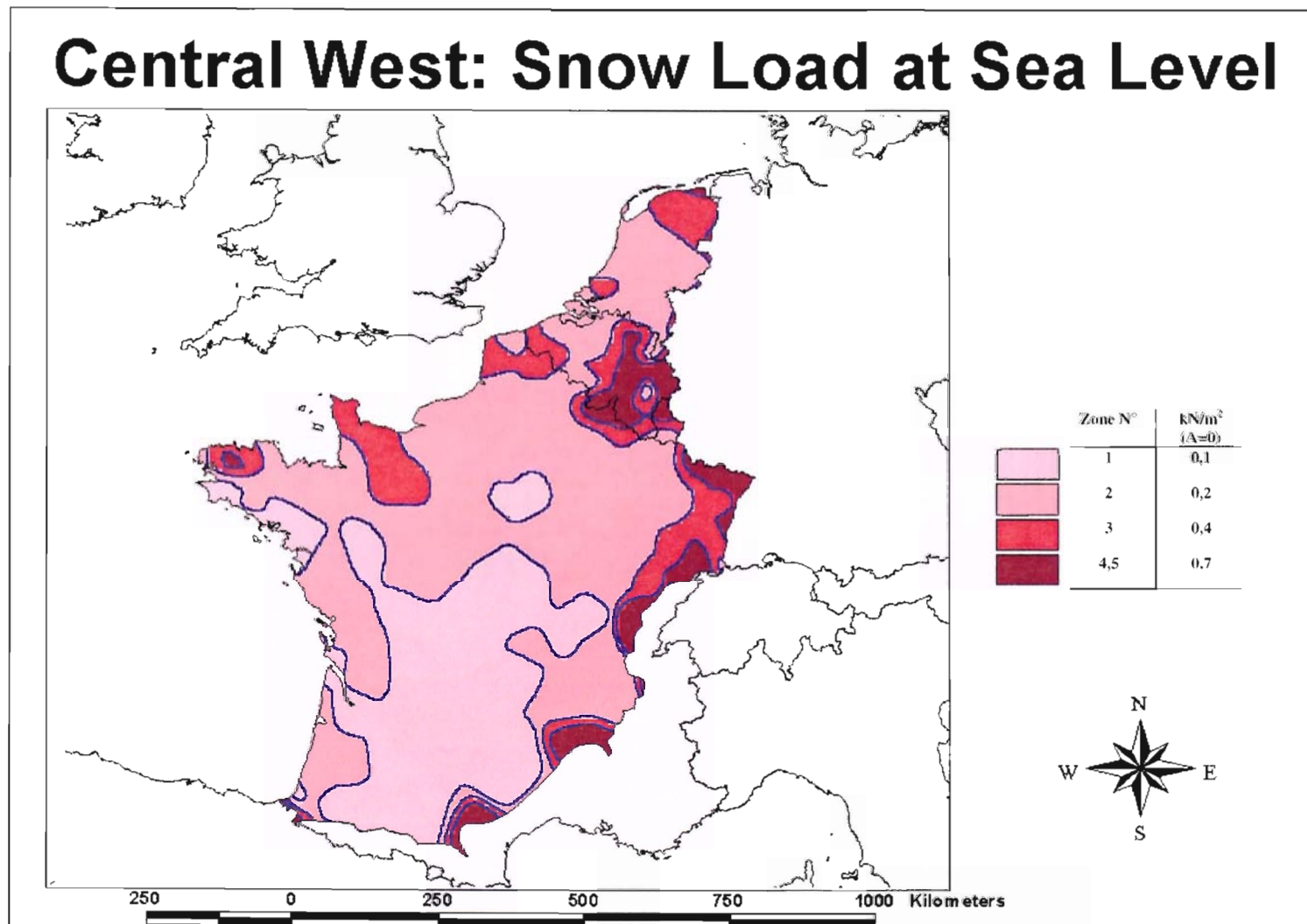

Figure C.7



## Sweden, Finland: Snow Load at Sea Level

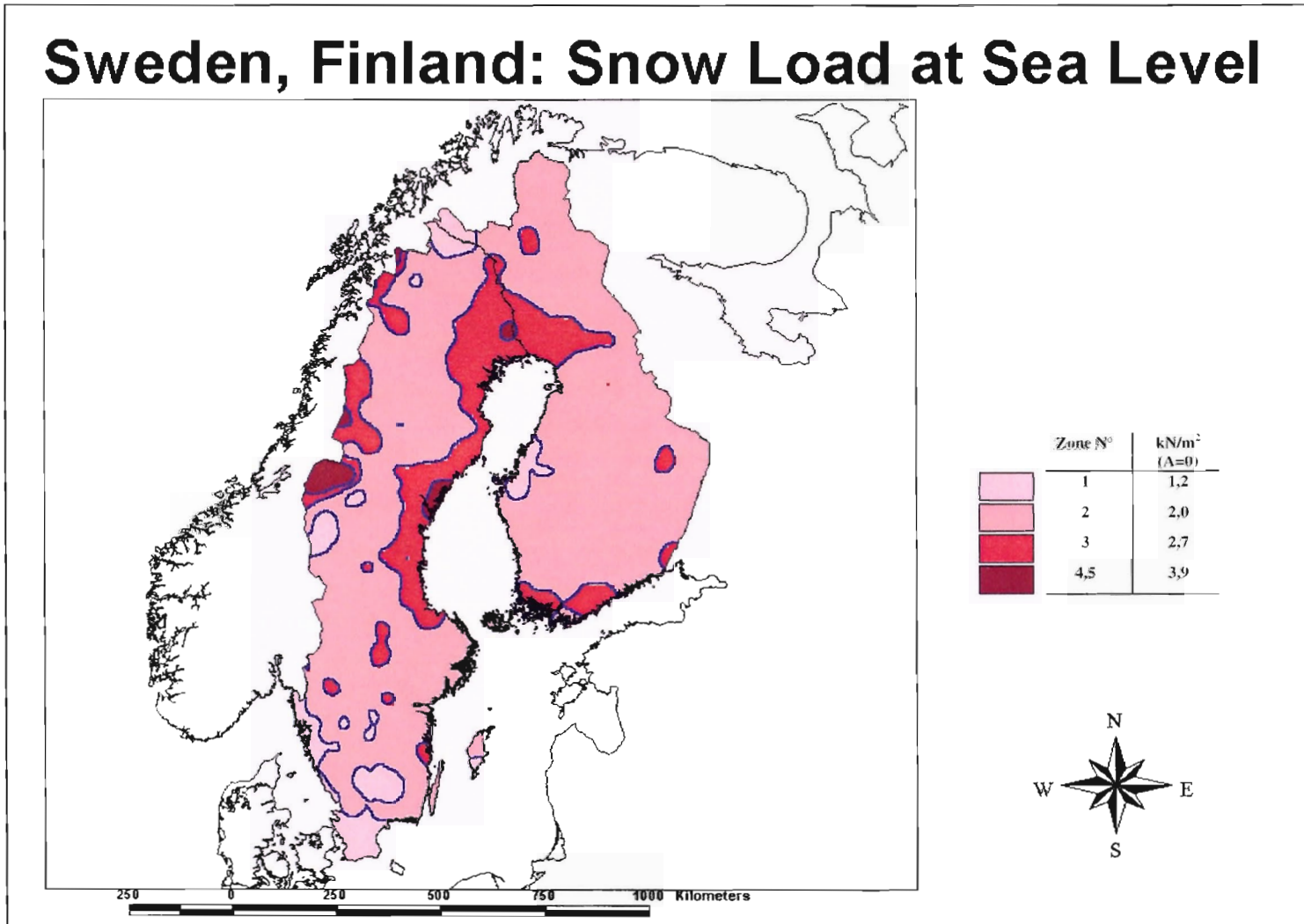

Figure C.8

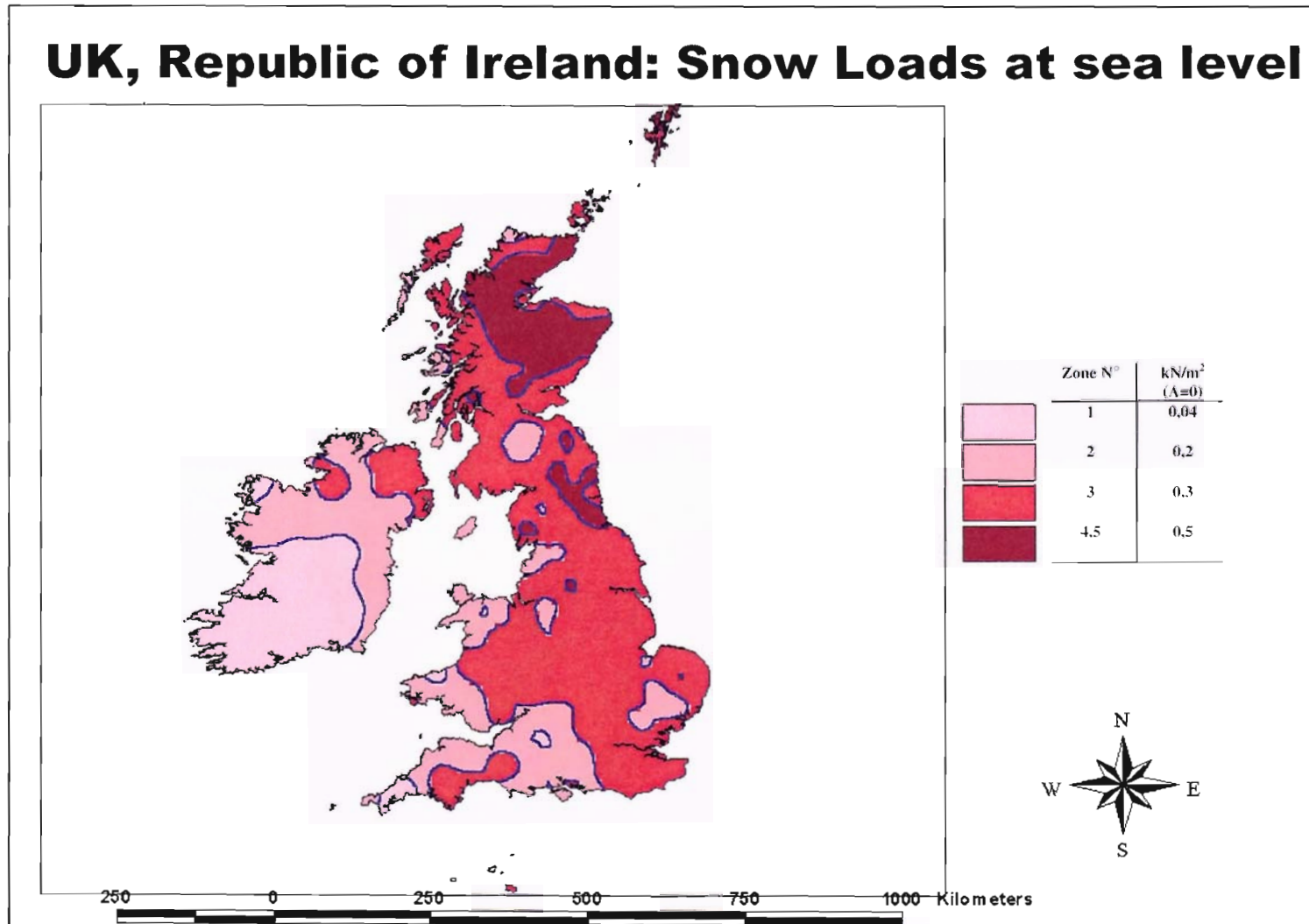

Figure C.9

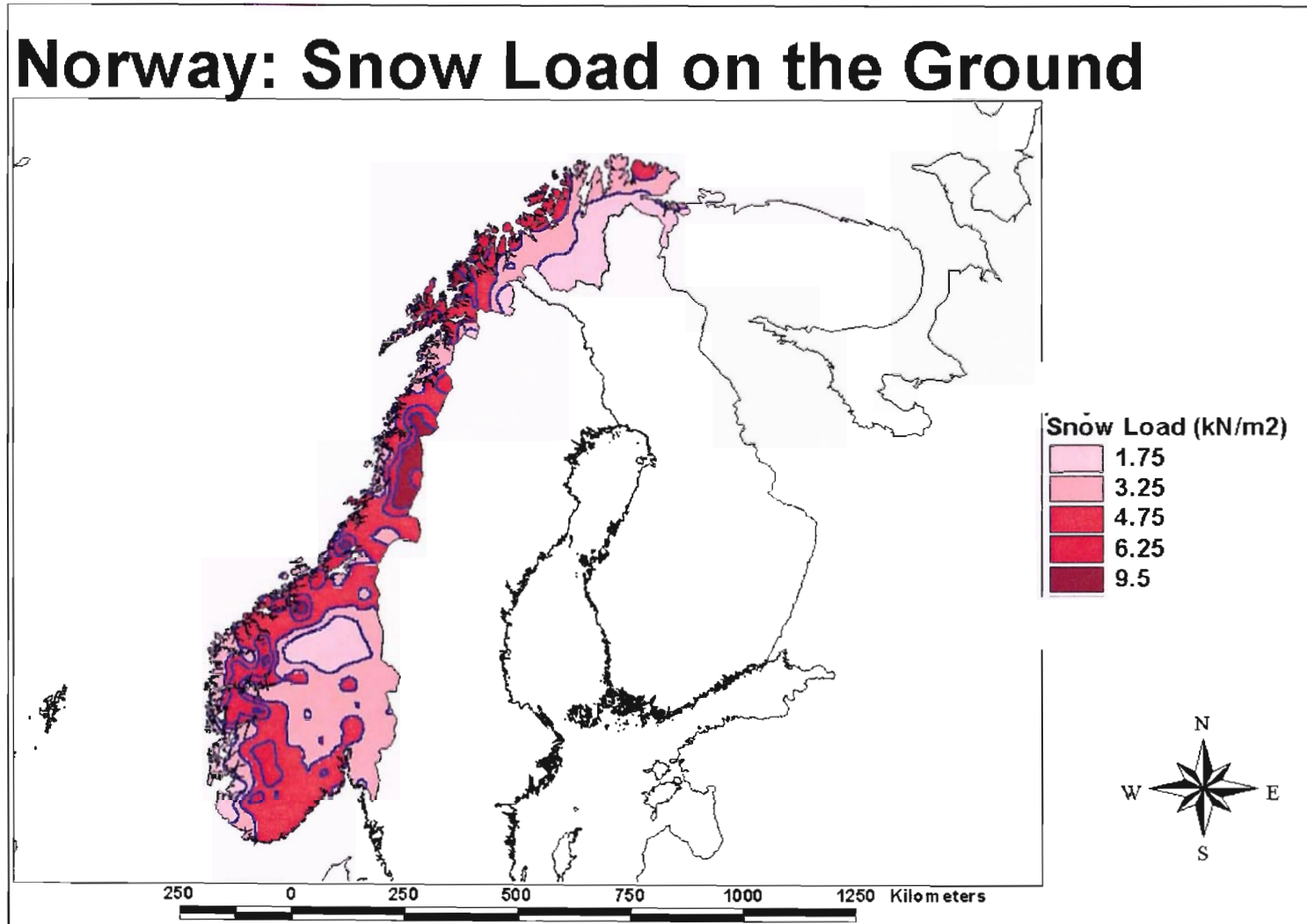

Figure C.10

## Czech Republic: Snow Load on the ground

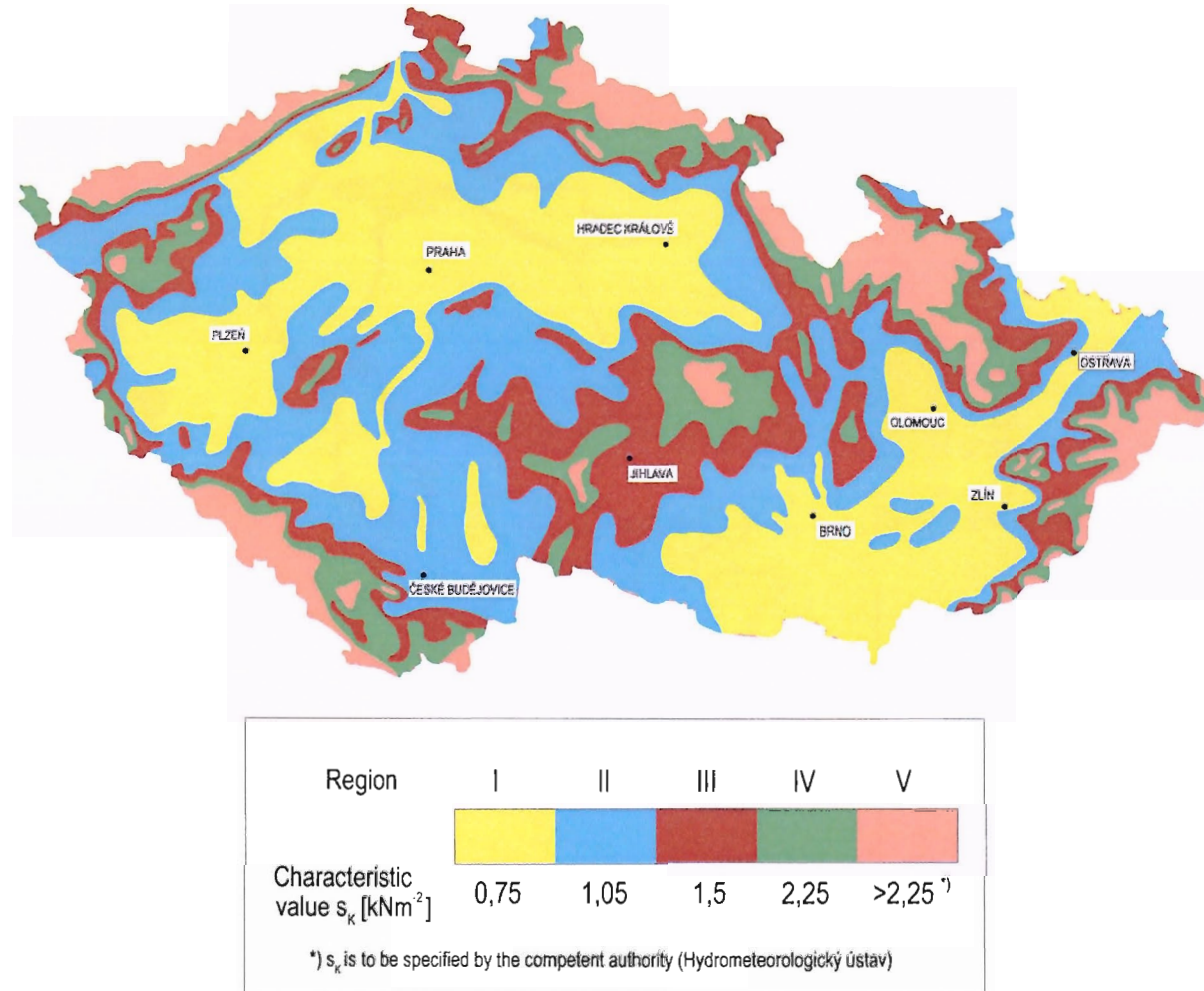

Figure C.11

# Snow Map of Iceland

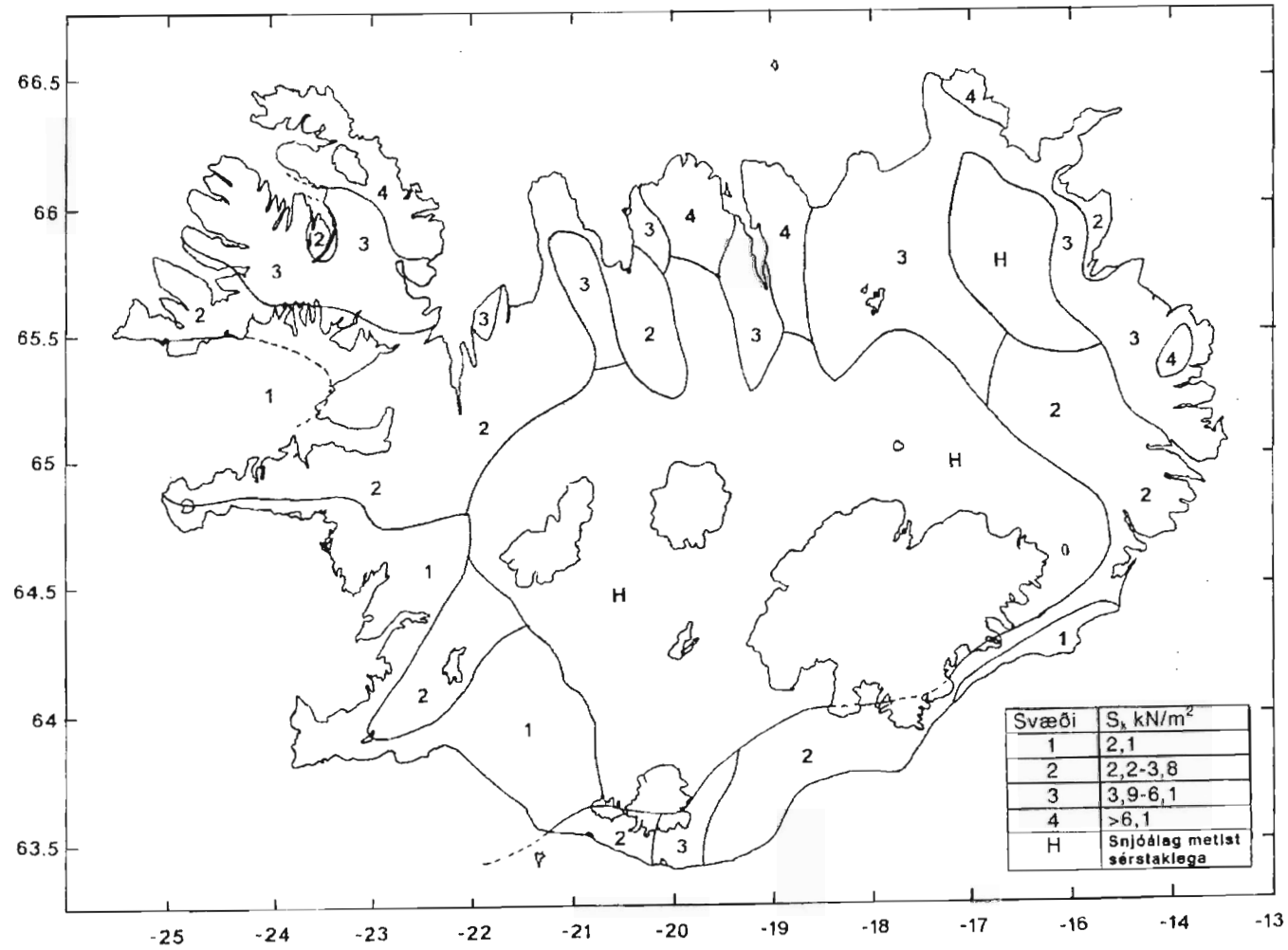

Figure C.12

## Snow Map of Poland

| Zone | $s_k$ , kN/m <sup>2</sup>             |
|------|---------------------------------------|
| 1    | $0,007A - 1,4$ ; $s_k \geq 0,70$      |
| 2    | 0,9                                   |
| 3    | $0,006A - 0,6$ ; $s_k \geq 1,2$       |
| 4    | 1,6                                   |
| 5    | $0,93\exp(0,00134A)$ ; $s_k \geq 2,0$ |

NOTE: A = Site altitude above sea level (m)

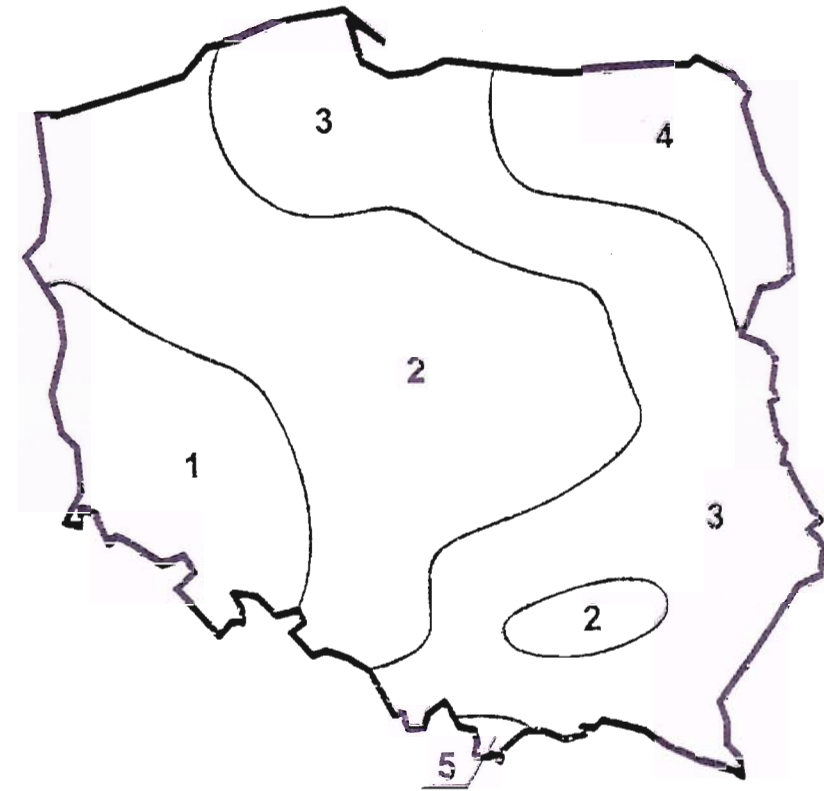

Figure C.13

## ANNEX D (informative)

### Adjustment of the ground snow load according to return period

(1) Ground level snow loads for any mean recurrence interval different to that for the characteristic snow load,  $s_k$ , (which by definition is based on annual probability of exceedence of 0,02) may be adjusted to correspond to characteristic values by application of D(2) to D(4). However, expression (D.1) should not be applied for annual probabilities of exceedence greater than 0,2 (i.e. return period less than approximately 5 years).

(2) If the available data show that the annual maximum snow load can be assumed to follow a Gumbel probability distribution, then the relationship between the characteristic value of the snow load on the ground and the snow load on the ground for a mean recurrence interval of  $n$  years is given by the formula:

$$s_n = s_k \left\{ \frac{1 - V \frac{\sqrt{6}}{\pi} [\ln(-\ln(1 - P_n)) + 0,57722]}{(1 + 2,5923V)} \right\} \quad (D.1)$$

where:

- $s_k$  is the characteristic snow load on the ground (with a return period of 50 years, in accordance with EN 1990:2002)
- $s_n$  is the ground snow load with a return period of  $n$  years;
- $P_n$  is the annual probability of exceedence (equivalent to approximately  $1/n$ , where  $n$  is the corresponding recurrence interval (years));
- $V$  is the coefficient of variation of annual maximum snow load.

**NOTE 1:** Where appropriate another distribution function for the adjustment of return period of ground snow load may be defined by the relevant national Authority.

**NOTE 2:** Information on the coefficient of variation may be given by the relevant national Authority.

(3) Expression (D.1) is shown graphically in Figure D.1.

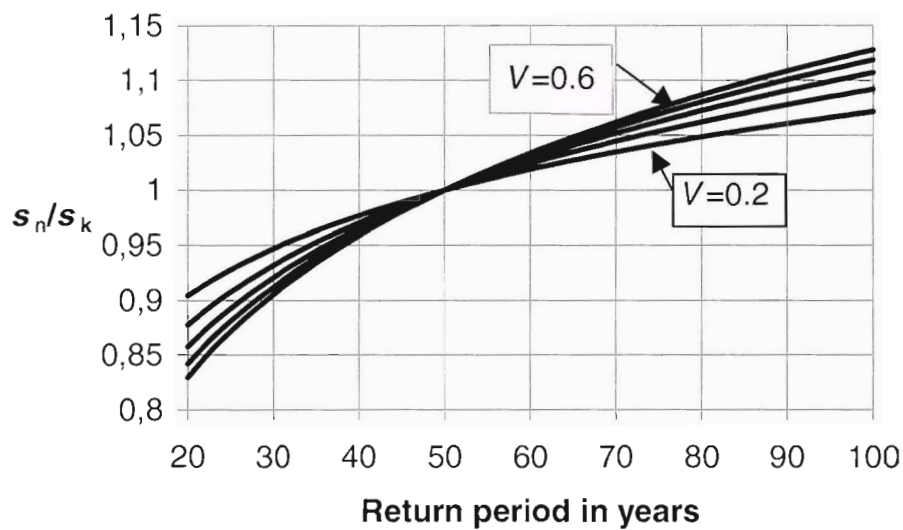

**Figure D.1 Adjustment of the ground snow load according to return period**

(4) Where permitted by the relevant national Authority expression (D.1) may also be  $\boxed{AC_1}$  adopted  $\langle AC_1 \rangle$  to calculate snow loads on the ground for other probabilities of exceedence. For example for:

- a) structures where a higher risk of exceedence is deemed acceptable
- b) structures where greater than normal safety is required



## ANNEX E (informative)

### Bulk weight density of snow

(1) The bulk weight density of snow varies. In general it increases with the duration of the snow cover and depends on the site location, climate and altitude.

(2) Except where specified in Sections 1 to 6 indicative values for the mean bulk weight density of snow on the ground given in Table E.1 may be used.

**Table E.1: Mean bulk weight density of snow**

| Type of snow                                   | Bulk weight density<br>[kN/m <sup>3</sup> ] |
|--|---|
| Fresh  | 1,0   |
| Settled (several hours or days after its fall) | 2,0   |
| Old (several weeks or months after its fall)   | 2,5 - 3,5                                   |
| Wet  | 4,0   |

## Bibliography

- |          |   |
|----------|---|
| ISO 4355 | Bases for design of structures – Determination of snow loads on roofs |
| ISO 3898 | Bases for design of structures - Notations – General symbols          |

