

# *The European Union*

## EDICT OF GOVERNMENT

In order to promote public education and public safety, equal justice for all, a better informed citizenry, the rule of law, world trade and world peace, this legal document is hereby made available on a noncommercial basis, as it is the right of all humans to know and speak the laws that govern them.

EN 1998-3 (2005) (English): Eurocode 8: Design of structures for earthquake resistance - Part 3: Assessment and retrofitting of buildings [Authority: The European Union Per Regulation 305/2011, Directive 98/34/EC, Directive 2004/18/EC]



BLANK PAGE



English version

**Eurocode 8: Design of structures for earthquake resistance -  
Part 3: Assessment and retrofitting of buildings**

Eurocode 8: Calcul des structures pour leur résistance aux  
séismes - Partie 3: Evaluation et renforcement des  
bâtiments

Eurocode 8: Auslegung von Bauwerken gegen Erdbeben -  
Teil 3: Beurteilung und Ertüchtigung von Gebäuden

This European Standard was approved by CEN on 15 March 2005.

CEN members are bound to comply with the CEN/CENELEC Internal Regulations which stipulate the conditions for giving this European Standard the status of a national standard without any alteration. Up-to-date lists and bibliographical references concerning such national standards may be obtained on application to the Central Secretariat or to any CEN member.

This European Standard exists in three official versions (English, French, German). A version in any other language made by translation under the responsibility of a CEN member into its own language and notified to the Central Secretariat has the same status as the official versions.

CEN members are the national standards bodies of Austria, Belgium, Cyprus, Czech Republic, Denmark, Estonia, Finland, France, Germany, Greece, Hungary, Iceland, Ireland, Italy, Latvia, Lithuania, Luxembourg, Malta, Netherlands, Norway, Poland, Portugal, Slovakia, Slovenia, Spain, Sweden, Switzerland and United Kingdom.



EUROPEAN COMMITTEE FOR STANDARDIZATION  
COMITÉ EUROPÉEN DE NORMALISATION  
EUROPÄISCHES KOMITEE FÜR NORMUNG

Management Centre: rue de Stassart, 36 B-1050 Brussels

<b>Contents</b>	<b>Page</b>
<b>FOREWORD</b> .....	<b>4</b>
<b>1 GENERAL</b> .....	<b>9</b>
<b>1.1 SCOPE</b> .....	<b>9</b>
<b>1.2 NORMATIVE REFERENCES</b> .....	<b>10</b>
1.2.1 <i>General reference standards</i> .....	<i>10</i>
<b>1.3 ASSUMPTIONS</b> .....	<b>10</b>
<b>1.4 DISTINCTION BETWEEN PRINCIPLES AND APPLICATION RULES</b> .....	<b>10</b>
<b>1.5 DEFINITIONS</b> .....	<b>10</b>
<b>1.6 SYMBOLS</b> .....	<b>10</b>
1.6.1 <i>General</i> .....	<i>10</i>
1.6.2 <i>Symbols used in Annex A</i> .....	<i>10</i>
1.6.3 <i>Symbols used in Annex B</i> .....	<i>12</i>
<b>1.7 S.I. UNITS</b> .....	<b>13</b>
<b>2 PERFORMANCE REQUIREMENTS AND COMPLIANCE CRITERIA</b> ...	<b>14</b>
<b>2.1 FUNDAMENTAL REQUIREMENTS</b> .....	<b>14</b>
<b>2.2 COMPLIANCE CRITERIA</b> .....	<b>15</b>
2.2.1 <i>General</i> .....	<i>15</i>
2.2.2 <i>Limit State of Near Collapse (NC)</i> .....	<i>15</i>
2.2.3 <i>Limit State of Significant Damage (SD)</i> .....	<i>16</i>
2.2.4 <i>Limit State of Damage Limitation (DL)</i> .....	<i>16</i>
<b>3 INFORMATION FOR STRUCTURAL ASSESSMENT</b> .....	<b>17</b>
<b>3.1 GENERAL INFORMATION AND HISTORY</b> .....	<b>17</b>
<b>3.2 REQUIRED INPUT DATA</b> .....	<b>17</b>
<b>3.3 KNOWLEDGE LEVELS</b> .....	<b>18</b>
3.3.1 <i>Definition of knowledge levels</i> .....	<i>18</i>
3.3.2 <i>KL1: Limited knowledge</i> .....	<i>19</i>
3.3.3 <i>KL2: Normal knowledge</i> .....	<i>20</i>
3.3.4 <i>KL3: Full knowledge</i> .....	<i>20</i>
<b>3.4 IDENTIFICATION OF THE KNOWLEDGE LEVEL</b> .....	<b>21</b>
3.4.1 <i>Geometry</i> .....	<i>21</i>
3.4.2 <i>Details</i> .....	<i>22</i>
3.4.3 <i>Materials</i> .....	<i>22</i>
3.4.4 <i>Definition of the levels of inspection and testing</i> .....	<i>23</i>
<b>3.5 CONFIDENCE FACTORS</b> .....	<b>23</b>
<b>4 ASSESSMENT</b> .....	<b>24</b>
<b>4.1 GENERAL</b> .....	<b>24</b>
<b>4.2 SEISMIC ACTION AND SEISMIC LOAD COMBINATION</b> .....	<b>24</b>
<b>4.3 STRUCTURAL MODELLING</b> .....	<b>24</b>
<b>4.4 METHODS OF ANALYSIS</b> .....	<b>25</b>
4.4.1 <i>General</i> .....	<i>25</i>
4.4.2 <i>Lateral force analysis</i> .....	<i>25</i>
4.4.3 <i>Multi-modal response spectrum analysis</i> .....	<i>26</i>
4.4.4 <i>Nonlinear static analysis</i> .....	<i>26</i>
4.4.5 <i>Non-linear time-history analysis</i> .....	<i>27</i>
4.4.6 <i>q-factor approach</i> .....	<i>27</i>

4.4.7	<i>Combination of the components of the seismic action</i> .....	27
4.4.8	<i>Additional measures for masonry infilled structures</i> .....	28
4.4.9	<i>Combination coefficients for variable actions</i> .....	28
4.4.10	<i>Importance classes and importance factors</i> .....	28
<b>4.5</b>	<b>SAFETY VERIFICATIONS</b> .....	<b>28</b>
4.5.1	<i>Linear methods of analysis (lateral force or modal response spectrum analysis)</i> .....	28
4.5.2	<i>Nonlinear methods of analysis (static or dynamic)</i> .....	29
4.5.3	<i>q-factor approach</i> .....	29
<b>4.6</b>	<b>SUMMARY OF CRITERIA FOR ANALYSIS AND SAFETY VERIFICATIONS</b> .....	<b>29</b>
<b>5</b>	<b>DECISIONS FOR STRUCTURAL INTERVENTION</b> .....	<b>31</b>
<b>5.1</b>	<b>CRITERIA FOR A STRUCTURAL INTERVENTION</b> .....	<b>31</b>
5.1.1	<i>Introduction</i> .....	31
5.1.2	<i>Technical criteria</i> .....	31
5.1.3	<i>Type of intervention</i> .....	31
5.1.4	<i>Non-structural elements</i> .....	32
5.1.5	<i>Justification of the selected intervention type</i> .....	32
<b>6</b>	<b>DESIGN OF STRUCTURAL INTERVENTION</b> .....	<b>34</b>
<b>6.1</b>	<b>RETROFIT DESIGN PROCEDURE</b> .....	<b>34</b>
<b>ANNEX A</b>	<b>(INFORMATIVE) REINFORCED CONCRETE STRUCTURES</b> .....	<b>35</b>
<b>ANNEX B</b>	<b>(INFORMATIVE) STEEL AND COMPOSITE STRUCTURES</b> .....	<b>55</b>
<b>ANNEX C</b>	<b>(INFORMATIVE) MASONRY BUILDINGS</b> .....	<b>81</b>

## Foreword

This European Standard EN 1998-3, Eurocode 8: Design of structures for earthquake resistance: Assessment and Retrofitting of buildings, has been prepared by Technical Committee CEN/TC 250 "Structural Eurocodes", the secretariat of which is held by BSI. CEN/TC 250 is responsible for all Structural Eurocodes.

This European Standard shall be given the status of a national standard, either by publication of an identical text or by endorsement, at the latest by December 2005, and conflicting national standards shall be withdrawn at the latest by March 2010.

This document supersedes ENV 1998-1-4:1996.

According to the CEN-CENELEC Internal Regulations, the National Standard Organisations of the following countries are bound to implement this European Standard: Austria, Belgium, Cyprus, Czech Republic, Denmark, Estonia, Finland, France, Germany, Greece, Hungary, Iceland, Ireland, Italy, Latvia, Lithuania, Luxembourg, Malta, Netherlands, Norway, Poland, Portugal, Slovakia, Slovenia, Spain, Sweden, Switzerland and United Kingdom.

## Background of the Eurocode programme

In 1975, the Commission of the European Community decided on an action programme in the field of construction, based on article 95 of the Treaty. The objective of the programme was the elimination of technical obstacles to trade and the harmonisation of technical specifications.

Within this action programme, the Commission took the initiative to establish a set of harmonised technical rules for the design of construction works which, in a first stage, would serve as an alternative to the national rules in force in the Member States and, ultimately, would replace them.

For fifteen years, the Commission, with the help of a Steering Committee with Representatives of Member States, conducted the development of the Eurocodes programme, which led to the first generation of European codes in the 1980's.

In 1989, the Commission and the Member States of the EU and EFTA decided, on the basis of an agreement<sup>1</sup> between the Commission and CEN, to transfer the preparation and the publication of the Eurocodes to CEN through a series of Mandates, in order to provide them with a future status of European Standard (EN). This links *de facto* the Eurocodes with the provisions of all the Council's Directives and/or Commission's Decisions dealing with European standards (*e.g.* the Council Directive 89/106/EEC on construction products - CPD - and Council Directives 93/37/EEC, 92/50/EEC and 89/440/EEC on public works and services and equivalent EFTA Directives initiated in pursuit of setting up the internal market).

The Structural Eurocode programme comprises the following standards generally consisting of a number of Parts:

---

<sup>1</sup> Agreement between the Commission of the European Communities and the European Committee for Standardisation (CEN) concerning the work on EUROCODES for the design of building and civil engineering works (BC/CEN/03/89).

- EN 1990 Eurocode: Basis of structural design
- EN 1991 Eurocode 1: Actions on structures
- EN 1992 Eurocode 2: Design of concrete structures
- EN 1993 Eurocode 3: Design of steel structures
- EN 1994 Eurocode 4: Design of composite steel and concrete structures
- EN 1995 Eurocode 5: Design of timber structures
- EN 1996 Eurocode 6: Design of masonry structures
- EN 1997 Eurocode 7: Geotechnical design
- EN 1998 Eurocode 8: Design of structures for earthquake resistance
- EN 1999 Eurocode 9: Design of aluminium structures

Eurocode standards recognise the responsibility of regulatory authorities in each Member State and have safeguarded their right to determine values related to regulatory safety matters at national level where these continue to vary from State to State.

### **Status and field of application of Eurocodes**

The Member States of the EU and EFTA recognise that Eurocodes serve as reference documents for the following purposes:

- as a means to prove compliance of building and civil engineering works with the essential requirements of Council Directive 89/106/EEC, particularly Essential Requirement N°1 - Mechanical resistance and stability - and Essential Requirement N°2 - Safety in case of fire;
- as a basis for specifying contracts for construction works and related engineering services;
- as a framework for drawing up harmonised technical specifications for construction products (ENs and ETAs)

The Eurocodes, as far as they concern the construction works themselves, have a direct relationship with the Interpretative Documents<sup>2</sup> referred to in Article 12 of the CPD, although they are of a different nature from harmonised product standards<sup>3</sup>. Therefore, technical aspects arising from the Eurocodes work need to be adequately considered by

---

<sup>2</sup> According to Art. 3.3 of the CPD, the essential requirements (ERs) shall be given concrete form in interpretative documents for the creation of the necessary links between the essential requirements and the mandates for hENs and ETAGs/ETAs.

<sup>3</sup> According to Art. 12 of the CPD the interpretative documents shall:

- a) give concrete form to the essential requirements by harmonising the terminology and the technical bases and indicating classes or levels for each requirement where necessary ;
- b) indicate methods of correlating these classes or levels of requirement with the technical specifications, e.g. methods of calculation and of proof, technical rules for project design, etc. ;
- c) serve as a reference for the establishment of harmonised standards and guidelines for European technical approvals.

The Eurocodes, *de facto*, play a similar role in the field of the ER 1 and a part of ER 2.

CEN Technical Committees and/or EOTA Working Groups working on product standards with a view to achieving a full compatibility of these technical specifications with the Eurocodes.

The Eurocode standards provide common structural design rules for everyday use for the design of whole structures and component products of both a traditional and an innovative nature. Unusual forms of construction or design conditions are not specifically covered and additional expert consideration will be required by the designer in such cases.

### **National Standards implementing Eurocodes**

The National Standards implementing Eurocodes will comprise the full text of the Eurocode (including any annexes), as published by CEN, which may be preceded by a National title page and National foreword, and may be followed by a National annex (informative).

The National annex may only contain information on those parameters which are left open in the Eurocode for national choice, known as Nationally Determined Parameters, to be used for the design of buildings and civil engineering works to be constructed in the country concerned, i.e.:

- values and/or classes where alternatives are given in the Eurocode,
- values to be used where a symbol only is given in the Eurocode,
- country specific data (geographical, climatic, etc.), *e.g.* snow map,
- the procedure to be used where alternative procedures are given in the Eurocode.

It may also contain

- decisions on the application of informative annexes,
- references to non-contradictory complementary information to assist the user to apply the Eurocode.

### **Links between Eurocodes and harmonised technical specifications (ENs and ETAs) for products**

There is a need for consistency between the harmonised technical specifications for construction products and the technical rules for works<sup>4</sup>. Furthermore, all the information accompanying the CE Marking of the construction products which refer to Eurocodes shall clearly mention which Nationally Determined Parameters have been taken into account.

### **Additional information specific to EN 1998-3**

Although assessment and retrofitting of existing structures for non-seismic actions is not yet covered by the relevant material-dependent Eurocodes, this Part of Eurocode 8 was specifically developed because:

---

<sup>4</sup> See Art.3.3 and Art.12 of the CPD, as well as clauses 4.2, 4.3.1, 4.3.2 and 5.2 of ID 1.



- For many older structures, seismic resistance was not considered during the original construction, whereas non-seismic actions were catered for, at least by means of traditional construction rules.
- Seismic hazard evaluations in accordance with present knowledge may indicate the need for retrofitting campaigns.
- Damage caused by earthquakes may create the need for major repairs.

Furthermore, since within the philosophy of Eurocode 8 the seismic design of new structures is based on a certain acceptable degree of structural damage in the event of the design earthquake, criteria for seismic assessment (of structures designed in accordance with Eurocode 8 and subsequently damaged) constitute an integral part of the entire process for seismic structural safety.

In seismic retrofitting situations, qualitative verifications for the identification and elimination of major structural defects are very important and should not be discouraged by the quantitative analytical approach proper to this Part of Eurocode 8. Preparation of documents of more qualitative nature is left to the initiative of the National Authorities.

This Standard addresses only the structural aspects of seismic assessment and retrofitting, which may form only one component of a broader strategy for seismic risk mitigation. This Standard will apply once the requirement to assess a particular building has been established. The conditions under which seismic assessment of individual buildings – possibly leading to retrofitting – may be required are beyond the scope of this Standard.

National programmes for seismic risk mitigation through seismic assessment and retrofitting may differentiate between “active” and “passive” seismic assessment and retrofitting programmes. “Active” programmes may require owners of certain categories of buildings to meet specific deadlines for the completion of the seismic assessment and – depending on its outcome – of the retrofitting. The categories of buildings selected to be targeted may depend on seismicity and ground conditions, importance class and occupancy and perceived vulnerability of the building (as influenced by type of material and construction, number of storeys, age of the building with respect to dates of older code enforcement, etc.). “Passive” programmes associate seismic assessment – possibly leading to retrofitting – with other events or activities related to the use of the building and its continuity, such as a change in use that increases occupancy or importance class, remodelling above certain limits (as a percentage of the building area or of the total building value), repair of damage after an earthquake, etc. The choice of the Limit States to be checked, as well as the return periods of the seismic action ascribed to the various Limit States, may depend on the adopted programme for assessment and retrofitting. The relevant requirements may be less stringent in “active” programmes than in “passive” ones; for example, in “passive” programmes triggered by remodelling, the relevant requirements may gradate with the extent and cost of the remodelling work undertaken.

In cases of low seismicity (see EN1998-1, **3.2.1(4)**), this Standard may be adapted to local conditions by appropriate National Annexes.

### **National annex for EN 1998-3**

This standard gives alternative procedures, values and recommendations for classes

with notes indicating where national choices may have to be made. Therefore the National Standard implementing EN 1998-3: 2005 should have a National annex containing all Nationally Determined Parameters to be used for the design of buildings and civil engineering works to be constructed in the relevant country.

National choice is allowed in EN 1998-3: 2005 through clauses:

Reference	Item
1.1(4)	Informative Annexes A, B and C.
2.1(2)P	Number of Limit States to be considered
2.1(3)P	Return period of seismic actions under which the Limit States should not be exceeded.
2.2.1(7)P	Partial factors for materials
3.3.1(4)	Confidence factors
3.4.4(1)	Levels of inspection and testing
4.4.2(1)P	Maximum value of the ratio $\rho_{\max}/\rho_{\min}$
4.4.4.5(2)	Complementary, non-contradictory information on non-linear static analysis procedures that can capture the effects of higher modes.
AC <sub>1</sub> A.4.4.2(5)	Partial factor $\gamma_{fd}$ for FRP debonding
A.4.4.2(9)	Partial factor $\gamma_{fd}$ of the FRP

## 1 GENERAL

### 1.1 Scope

(1) The scope of Eurocode 8 is defined in EN 1998-1: 2004, **1.1.1** and the scope of this Standard is defined in **(2)**, **(4)** and **(5)**. Additional parts of Eurocode 8 are indicated in EN 1998-1: 2004, **1.1.3**.

(2) The scope of EN 1998-3 is as follows:

- To provide criteria for the evaluation of the seismic performance of existing individual building structures.
- To describe the approach in selecting necessary corrective measures
- To set forth criteria for the design of retrofitting measures (i.e. conception, structural analysis including intervention measures, final dimensioning of structural parts and their connections to existing structural elements).

NOTE For the purposes of this standard, retrofitting covers both the strengthening of undamaged structures and the repair of earthquake damaged structures.

(3) When designing a structural intervention to provide adequate resistance against seismic actions, structural verifications should also be made with respect to non-seismic load combinations.

(4) Reflecting the basic requirements of EN 1998-1: 2004, this Standard covers the seismic assessment and retrofitting of buildings made of the more commonly used structural materials: concrete, steel, and masonry.

NOTE Informative Annexes A, B and C contain additional information related to the assessment of reinforced concrete, steel and composite, and masonry buildings, respectively, and to their upgrading when necessary.

(5) Although the provisions of this Standard are applicable to all categories of buildings, the seismic assessment and retrofitting of monuments and historical buildings often requires different types of provisions and approaches, depending on the nature of the monuments.

(6) Since existing structures:

- (i) reflect the state of knowledge at the time of their construction,
- (ii) possibly contain hidden gross errors,
- (iii) may have been submitted to previous earthquakes or other accidental actions with unknown effects,

structural evaluation and possible structural intervention are typically subjected to a different degree of uncertainty (level of knowledge) than the design of new structures. Different sets of material and structural safety factors are therefore required, as well as different analysis procedures, depending on the completeness and reliability of the information available.

## **1.2 Normative references**

(1)P This European Standard incorporates by dated or undated reference, provisions from other publications. These normative references are cited at the appropriate places in the text and the publications are listed hereafter. For dated references, subsequent amendments to or revisions of any of these publications apply to this European Standard only when incorporated in it by amendment or revision. For undated references the latest edition of the publication referred to applies (including amendments).

### **1.2.1 General reference standards**

EN 1990 Eurocode - Basis of structural design

EN 1998-1 Eurocode 8 - Design of structures for earthquake resistance – Part 1: General rules, seismic actions and rules for buildings

## **1.3 Assumptions**

(1) Reference is made to EN 1998-1: 2004, **1.3**.

(2) The provisions of this Standard assume that the data collection and tests is performed by experienced personnel and that the engineer responsible for the assessment, the possible design of the retrofitting and the execution of work has appropriate experience of the type of structures being strengthened or repaired.

(3) Inspection procedures, check-lists and other data-collection procedures should be documented and filed, and should be referred to in the design documents.

## **1.4 Distinction between principles and application rules**

(1) The rules of EN 1990: 2002, **1.4** apply.

## **1.5 Definitions**

(1) Reference is made to EN 1998-1: 2004, **1.5**.

## **1.6 Symbols**

### **1.6.1 General**

(1) Reference is made to EN 1998-1: 2004, **1.6**.

(2) Further symbols used in this Standard are defined in the text where they occur.

### **1.6.2 Symbols used in Annex A**

$b$  width of steel straps in steel jacket

$b_o$  and  $h_o$  dimension of confined concrete core to the centreline of the hoop

$b_i$  centreline spacing of longitudinal bars

$c$  concrete cover to reinforcement

$d$  effective depth of section (depth to the tension reinforcement)

$d'$	depth to the compression reinforcement
$d_{bL}$	diameter of tension reinforcement
$f_c$	concrete compressive strength (MPa)
$f_{cc}$	confined concrete strength
$f_{cd}$	design value of concrete strength
$f_{ctm}$	concrete mean tensile strength
$f_{idd,e}$	design value of FRP (fibre-reinforced polymer) effective debonding strength
$f_{tu,W}(R)$	ultimate strength of FRP sheet wrapped around corner with radius $R$ , expression (A.25)
$f_y$	estimated mean value of steel yield strength
$f_{yd}$	design value of yield strength of (longitudinal) reinforcement
$f_{yj,d}$	design value of yield strength jacket steel
$f_{yw}$	yield stress of transverse or confinement reinforcement
$h$	depth of cross-section
$k_b = \sqrt{1,5 \cdot (2 - w_f/s_f)/(1 + w_f/100 \text{ mm})}$	covering coefficient of FRP (fibre-reinforced polymer) strips/sheet
$n$	number of spliced bars along perimeter $p$
$p$	length of perimeter line in column section along the inside of longitudinal steel
$s$	centreline spacing of stirrups
$s_f$	centreline spacing of FRP (fibre-reinforced polymer) strips ( $=w_f$ for FRP sheets)
$t_f$	thickness of FRP (fibre-reinforced polymer) sheet
$t_j$	thickness of steel jacket
$x$	compression zone depth
$w_f$	width of FRP (fibre-reinforced polymer) strip/sheet
$z$	length of section internal lever arm
$A_c$	column cross-section area
$A_f$	$= t_f w_f \sin \beta$ : horizontally projected cross-section area of FRP (fibre-reinforced polymer) strip/sheet with thickness $t_f$ , width $w_f$ and angle $\beta$
$A_s$	cross-sectional area of longitudinal steel reinforcement
$A_{sw}$	cross-sectional area of stirrup
$E_f$	FRP (fibre-reinforced polymer) modulus
$L_V=M/V$	shear span at member end
$N$	axial force (positive for compression)
$V_{R,c}$	shear resistance of member without web reinforcement
$V_{R,max}$	shear resistance as determined by crushing in the diagonal compression strut
$V_w$	contribution of transverse reinforcement to shear resistance

$\alpha$	confinement effectiveness factor
$\gamma_{cl}$	factor, greater than 1,0 for primary seismic and equal to 1,0 for secondary seismic elements
$\gamma_{fd}$	partial factor for FRP (fibre-reinforced polymer) debonding
$\delta$	angle between the diagonal and the axis of a column
$\varepsilon_{cu}$	concrete ultimate strain
$\varepsilon_{ju}$	FRP (fibre-reinforced polymer) ultimate strain
$\varepsilon_{su,w}$	ultimate strain of confinement reinforcement
$\theta$	strut inclination angle in shear design
$\theta_y$	chord rotation at yielding of concrete member
$\theta_u$	ultimate chord rotation of concrete member
$\nu$	$= N / bhf_c$ ( $b$ width of compression zone)
$\rho_d$	steel ratio of diagonal reinforcement
$\rho_f$	volumetric ratio of FRP (fibre-reinforced polymer)
$\rho_s$	geometric steel ratio
$\rho_{sx}$	$= A_{sx} / b_w s_h =$ ratio of transverse steel parallel to direction $x$ of loading ( $s_h =$ stirrup spacing)
$\rho_{tot}$	total longitudinal reinforcement ratio
$\rho_{sw}$	volumetric ratio of confinement reinforcement
$\rho_w$	transverse reinforcement ratio
$\varphi_u$	ultimate curvature at end section
$\varphi_y$	yield curvature at end section
$\omega, \omega'$	mechanical reinforcement ratio of tension and compression reinforcement

### **1.6.3 Symbols used in Annex B**

$b_{cp}$	width of the cover plate
$b_f$	flange width
$d_c$	column depth
$d_z$	panel-zone depth between continuity plates
$e$	distance between the plastic hinge and the column face
$f_c$	concrete compressive strength
$f_{ct}$	tensile strength of the concrete
$f_{uw}$	tensile strength of the welds
$f_{ywh}$	yield strength of transverse reinforcement
$f_{y,pl}$	nominal yield strength of each flange

$l_{cp}$	length of the cover plate
$t_{cp}$	thickness of the cover plate
$t_f$	thickness
$t_{hw}$	web thickness
$w_z$	panel-zone width between column flanges
$A_g$	gross area of the section
$A_{hf}$	area of the haunch flange
$A_{pl}$	area of each flange
$B_S$	width of the steel flat-bar brace
$B$	width of the composite section
$E$	Young's modulus of the beam
$E_B$	elastic modulus of the RC (reinforced concrete) panel
$F_t$	seismic base shear
$H$	frame height
$H_c$	storey height of the frame
$K_\varphi$	connection rotation stiffness
$I$	moment of inertia
$L$	beam span
$M_{pb,Rd}$	beam plastic moment
$N_d$	design axial
$N_y$	yield strength of the steel brace
$S_x$	beam elastic (major) modulus;
$T_C$	thickness of the panel
$V_{pl,Rd,b}$	shear force at a beam plastic hinge
$Z_b$	plastic modulus of the beam
$Z_e$	effective plastic modulus of the section at the plastic hinge location
$\rho_w$	ratio of transverse reinforcement

## 1.7 S.I. Units

- (1) Reference is made to EN 1998-1: 2004, **1.7**.

## 2 PERFORMANCE REQUIREMENTS AND COMPLIANCE CRITERIA

### 2.1 Fundamental requirements

(1)P The fundamental requirements refer to the state of damage in the structure, herein defined through three Limit States (LS), namely Near Collapse (NC), Significant Damage (SD), and Damage Limitation (DL). These Limit States shall be characterised as follows:

LS of Near Collapse (NC). The structure is heavily damaged, with low residual lateral strength and stiffness, although vertical elements are still capable of sustaining vertical loads. Most non-structural components have collapsed. Large permanent drifts are present. The structure is near collapse and would probably not survive another earthquake, even of moderate intensity.

LS of Significant Damage (SD). The structure is significantly damaged, with some residual lateral strength and stiffness, and vertical elements are capable of sustaining vertical loads. Non-structural components are damaged, although partitions and infills have not failed out-of-plane. Moderate permanent drifts are present. The structure can sustain after-shocks of moderate intensity. The structure is likely to be uneconomic to repair.

LS of Damage Limitation (DL). The structure is only lightly damaged, with structural elements prevented from significant yielding and retaining their strength and stiffness properties. Non-structural components, such as partitions and infills, may show distributed cracking, but the damage could be economically repaired. Permanent drifts are negligible. The structure does not need any repair measures.

NOTE The definition of the Limit State of Collapse given in this Part 3 of Eurocode 8 is closer to the actual collapse of the building than the one given in EN1998-1: 2004 and corresponds to the fullest exploitation of the deformation capacity of the structural elements. The Limit State associated with the 'no collapse' requirement in EN1998-1: 2004 is roughly equivalent to the one that is here defined as Limit State of Significant Damage.

(2)P The National Authorities decide whether all three Limit States shall be checked, or two of them, or just one of them.

NOTE The choice of  $\boxed{AC_1}$  the Limit States to be checked in a country  $\langle AC_1 \rangle$ , among the three Limit States defined in 2.1(1)P, may be found in the National Annex.

(3)P The appropriate levels of protection are achieved by selecting, for each of the Limit States, a return period for the seismic action.

NOTE The return periods ascribed to the various Limit States to be checked in a country may be found in its National Annex. The protection normally considered appropriate for ordinary new buildings is considered to be achieved by selecting the following values for the return periods:

- LS of Near Collapse (NC): 2.475 years, corresponding to a probability of exceedance of 2% in 50 years
- LS of Significant Damage (SD): 475 years, corresponding to a probability of exceedance of 10% in 50 years
- LS of Damage Limitation (DL): 225 years, corresponding to a probability of exceedance of 20% in 50 years.



## 2.2 Compliance criteria

### 2.2.1 General

(1)P Compliance with the requirements in **2.1** is achieved by adoption of the seismic action, method of analysis, verification and detailing procedures contained in this part of EN 1998, as appropriate for the different structural materials within its scope (i.e. concrete, steel, masonry).

(2)P Except when using the  $q$ -factor approach, compliance is checked by making use of the full (unreduced, elastic) seismic action as defined in **2.1** and **4.2** for the appropriate return period.

(3)P For the verification of the structural elements a distinction is made between ‘ductile’ and ‘brittle’ ones. Except when using the  $q$ -factor approach, the former shall be verified by checking that demands do not exceed the corresponding capacities in terms of deformations. The latter shall be verified by checking that demands do not exceed the corresponding capacities in terms of strengths.

NOTE Information for classifying components/mechanisms as “ductile” or “brittle” may be found in the relevant material-related Annexes.

(4)P Alternatively, a  $q$ -factor approach may be used, where use is made of a seismic action reduced by a  $q$ -factor, as indicated in **4.2(3)P**. In safety verifications all structural elements shall be verified by checking that demands due to the reduced seismic action do not exceed the corresponding capacities in terms of strengths evaluated in accordance with **(5)P**.

(5)P For the calculation of the capacities of ductile or brittle elements, where these will be compared with demands for safety verifications in accordance with **(3)P** and **(4)P**, mean value properties of the existing materials shall be used as directly obtained from *in-situ* tests and from the additional sources of information, appropriately divided by the confidence factors defined in **3.5**, accounting for the level of knowledge attained. Nominal properties shall be used for new or added materials.

(6)P Some of the existing structural elements may be designated as “secondary seismic”, in accordance with the definitions in EN 1998-1: 2004, **4.2.2 (1)P**, **(2)** and **(3)**. “Secondary seismic” elements shall be verified with the same compliance criteria as primary seismic ones, but using less conservative estimates of their capacity than for the elements considered as “primary seismic”.

(7)P In the calculation of strength capacities of brittle “primary seismic” elements, material strengths shall be divided by the partial factor of the material.

NOTE: The values ascribed to the partial factors for steel, concrete, structural steel, masonry and other materials for use in a country can be found in the National Annex to this standard. Notes to clauses **5.2.4(3)**, **6.1.3(1)**, **7.1.3(1)** and **9.6(3)** in EN1998-1: 2004 refer to the values of partial factors for steel, concrete, structural steel and masonry to be used for the design of new buildings in different countries.

### 2.2.2 Limit State of Near Collapse (NC)

(1)P Demands shall be based on the design seismic action relevant to this Limit State. For ductile and brittle elements demands shall be evaluated based on the results

of the analysis. If a linear method of analysis is used, demands on brittle elements shall be modified in accordance to **4.5.1(1)P**.

(2)P Capacities shall be based on appropriately defined ultimate deformations for ductile elements and on ultimate strengths for brittle ones.

(3) The  $q$ -factor approach (see **2.2.1(4)P**, **4.2(3)P**) is generally not suitable for checking this Limit State.

NOTE The values of  $q = 1,5$  and  $2,0$  quoted in **4.2(3)P** for reinforced concrete and steel structures, respectively, as well as the higher values of  $q$  possibly justified with reference to the local and global available ductility in accordance with the relevant provisions of EN 1998-1:2004, correspond to fulfilment of the Significant Damage Limit State. If it is chosen to use this approach to check the Near Collapse Limit State, then **2.2.3(3)P** may be applied, with a value of the  $q$ -factor exceeding those in **4.2(3)P** by about one-third.

### **2.2.3 Limit State of Significant Damage (SD)**

(1)P Demands shall be based on the design seismic action relevant to this Limit State. For ductile and brittle elements demands shall be evaluated based on the results of the analysis. In case a linear method of analysis is used, demands on brittle elements shall be modified in accordance to **4.5.1(1)P**.

(2)P Except when using the  $q$ -factor approach, capacities shall be based on damage-related deformations for ductile elements and on conservatively estimated strengths for brittle ones.

(3)P In the  $q$ -factor approach (see **2.2.1(4)P**, **4.2(3)P**), demands shall be based on the reduced seismic action and capacities shall be evaluated as for non-seismic design situations.

### **2.2.4 Limit State of Damage Limitation (DL)**

(1)P Demands shall be based on the design seismic action relevant to this Limit State.

(2)P Except when using the  $q$ -factor approach, capacities shall be based on yield strengths for all structural elements, both ductile and brittle. Capacities of infills shall be based on mean interstorey drift capacity for the infills.

(3)P In the  $q$ -factor approach (see **2.2.1(4)P**, **4.2(3)P**), demands and capacities shall be compared in terms of mean interstorey drift.

### 3 INFORMATION FOR STRUCTURAL ASSESSMENT

#### 3.1 General information and history

(1)P In assessing the earthquake resistance of existing structures, the input data shall be collected from a variety of sources, including:

- available documentation specific to the building in question,
- relevant generic data sources (e.g. contemporary codes and standards),
- field investigations and,
- in most cases, in-situ and/or laboratory measurements and tests, as described in more detail in **3.2** and **3.4**.

(2) Cross-checks should be made between the data collected from different sources to minimise uncertainties.

#### 3.2 Required input data

(1) In general, the information for structural evaluation should cover the following points from a) to i).

a) Identification of the structural system and of its compliance with the regularity criteria in EN 1998-1: 2004, **4.2.3**. The information should be collected either from on site investigation or from original design drawings, if available. In this latter case, information on possible structural changes since construction should also be collected.

b) Identification of the type of building foundations.

c) Identification of the ground conditions as categorised in EN 1998-1: 2004, **3.1**.

d) Information about the overall dimensions and cross-sectional properties of the building elements and the mechanical properties and condition of constituent materials.

e) Information about identifiable material defects and inadequate detailing.

f) Information on the seismic design criteria used for the initial design, including the value of the force reduction factor ( $q$ -factor), if applicable.

g) Description of the present and/or the planned use of the building (with identification of its importance class, as described in EN 1998-1: 2004, **4.2.5**).

h) Re-assessment of imposed actions taking into account the use of the building.

i) Information about the type and extent of previous and present structural damage, if any, including earlier repair measures.

(2)P Depending on the amount and quality of the information collected on the points above, different types of analysis and different values of the confidence factors shall be adopted, as indicated in **3.3**.

### 3.3 Knowledge levels

#### 3.3.1 Definition of knowledge levels

(1) For the purpose of choosing the admissible type of analysis and the appropriate confidence factor values, the following three knowledge levels are defined:

KL1 : Limited knowledge

KL2 : Normal knowledge

KL3 : Full knowledge

(2) The factors determining the appropriate knowledge level (i.e. KL1, KL2 or KL3) are:

i) *geometry*: the geometrical properties of the structural system, and of such non-structural elements (e.g. masonry infill panels) as may affect structural response.

ii) *details*: these include the amount and detailing of reinforcement in reinforced concrete, connections between steel members, the connection of floor diaphragms to lateral resisting structure, the bond and mortar jointing of masonry and the nature of any reinforcing elements in masonry,

iii) *materials*: the mechanical properties of the constituent materials.

(3) The knowledge level achieved determines the allowable method of analysis (see 4.4), as well as the values to be adopted for the confidence factors (CF). The procedures for obtaining the required data are given in 3.4.

(4) The relationship between knowledge levels and applicable methods of analysis and confidence factors is illustrated in Table 3.1. The definitions of the terms 'visual', 'full', 'limited', 'extended' and 'comprehensive' in the Table are given in 3.4.

**Table 3.1: Knowledge levels and corresponding methods of analysis (LF: Lateral Force procedure, MRS: Modal Response Spectrum analysis) and confidence factors (CF).**

Knowledge Level	Geometry	Details	Materials	Analysis	CF
KL1	From original outline construction drawings with sample <b>visual</b> survey <b>or</b> from <b>full</b> survey	Simulated design in accordance with relevant practice <b>and</b> from <b>limited in-situ</b> inspection	Default values in accordance with standards of the time of construction <b>and</b> from <b>limited in-situ</b> testing	LF- MRS	$CF_{KL1}$
KL2		From incomplete original detailed construction drawings with <b>limited in-situ</b> inspection <b>or</b> from <b>extended in-situ</b> inspection	From original design specifications with <b>limited in-situ</b> testing <b>or</b> from <b>extended in-situ</b> testing	All	$CF_{KL2}$
KL3		From original detailed construction drawings with <b>limited in-situ</b> inspection <b>or</b> from <b>comprehensive in-situ</b> inspection	From original test reports with <b>limited in-situ</b> testing <b>or</b> from <b>comprehensive in-situ</b> testing	All	$CF_{KL3}$

NOTE The values ascribed to the confidence factors to be used in a country may be found in its National Annex. The recommended values are  $CF_{KL1} = 1,35$ ,  $CF_{KL2} = 1,20$  and  $CF_{KL3} = 1,00$ .

### 3.3.2 KL1: Limited knowledge

(1) KL1 corresponds to the following state of knowledge:

i) *geometry*: the overall structural geometry and member sizes are known either (a) from survey; or (b) from original outline construction drawings used for both the

original construction and any subsequent modifications. In case (b), a sufficient sample of dimensions of both overall geometry and member sizes should be checked on site; if there are significant discrepancies from the outline construction drawings, a fuller dimensional survey should be performed.

ii) *details*: the structural details are not known from detailed construction drawings and may be assumed based on simulated design in accordance with usual practice at the time of construction; in this case, limited inspections in the most critical elements should be performed to check that the assumptions correspond to the actual situation. Otherwise, more extensive *in-situ* inspection is required.

iii) *materials*: no direct information on the mechanical properties of the construction materials is available, either from original design specifications or from original test reports. Default values should be assumed in accordance with standards at the time of construction, accompanied by limited *in-situ* testing in the most critical elements.

(2) The information collected should be sufficient for performing local verifications of element capacity and for setting up a linear structural analysis model.

(3) Structural evaluation based on a state of limited knowledge should be performed through linear analysis methods, either static or dynamic (see 4.4).

### 3.3.3 KL2: Normal knowledge

(1) KL2 corresponds to the following state of knowledge:

i) *geometry*: the overall structural geometry and member sizes are known either (a) from an extended survey or (b) from outline construction drawings used for both the original construction and any subsequent modifications. In case (b), a sufficient sample of dimensions of both overall geometry and member sizes should be checked on site; if there are significant discrepancies from the outline construction drawings, a fuller dimensional survey is required.

ii) *details*: the structural details are known either from extended *in-situ* inspection or from incomplete detailed construction drawings. In the latter case, limited *in-situ* inspections in the most critical elements should be performed to check that the available information corresponds to the actual situation.

iii) *materials*: information on the mechanical properties of the construction materials is available either from extended *in-situ* testing or from original design specifications. In this latter case, limited *in-situ* testing should be performed.

(2) The information collected should be sufficient for performing local verifications of element capacity and for setting up a linear or nonlinear structural model.

(3) Structural evaluation based on this state of knowledge may be performed through either linear or nonlinear analysis methods, either static or dynamic (see 4.4).

### 3.3.4 KL3: Full knowledge

(1) KL3 corresponds to the following state of knowledge:

i) *geometry*: the overall structural geometry and member sizes are known either (a)

from a comprehensive survey or (b) from the complete set of outline construction drawings used for both the original construction and any subsequent modifications. In case (b), a sufficient sample of both overall geometry and member sizes should be checked on site; if there are significant discrepancies from the outline construction drawings, a fuller dimensional survey is required.

ii) *details*: the structural details are known either from comprehensive *in-situ* inspection or from a complete set of detailed construction drawings. In the latter case, limited *in-situ* inspections in the most critical elements should be performed to check that the available information corresponds to the actual situation.

iii) *materials*: information on the mechanical properties of the construction materials is available either from comprehensive *in-situ* testing or from original test reports. In this latter case, limited *in-situ* testing should be performed.

(2) 3.3.3(2) applies.

(3) 3.3.3(3) applies.

### 3.4 Identification of the Knowledge Level

#### 3.4.1 Geometry

##### 3.4.1.1 Outline construction drawings

(1) The outline construction drawings are those documents that describe the geometry of the structure, allowing for identification of structural components and their dimensions, as well as the structural system to resist both vertical and lateral actions.

##### 3.4.1.2 Detailed construction drawings

(1) The detailed drawings are those documents that describe the geometry of the structure, allowing for identification of structural components and their dimensions, as well as the structural system to resist both vertical and lateral actions. In addition, they contain information about details (as specified in 3.3.1(2)).

##### 3.4.1.3 Visual survey

(1) A visual survey is a procedure for checking correspondence between the actual geometry of the structure with the available outline construction drawings. Sample geometry measurements on selected elements should be carried out. Possible structural changes which may have occurred during or after construction should be subjected to a survey as in 3.4.1.4.

##### 3.4.1.4 Full survey

(1) A full survey is a procedure resulting in the production of structural drawings that describe the geometry of the structure, allowing for identification of structural components and their dimensions, as well as the structural system to resist both vertical and lateral actions.

### 3.4.2 Details

(1) Reliable non-destructive methods may be adopted in the inspections specified as follows:

#### 3.4.2.1 Simulated design

(1) A simulated design is a procedure resulting in the definition of the amount and layout of reinforcement, both longitudinal and transverse, in all elements participating in the vertical and lateral resistance of the building. The design should be carried out based on regulatory documents and state of the practice used at the time of construction.

#### 3.4.2.2 Limited in-situ inspection

(1) A limited *in-situ* inspection is a procedure for checking correspondence between the actual details of the structure with either the available detailed construction drawings or the results of the simulated design in 3.4.2.1. This entails performing inspections as indicated in 3.4.4(1)P.

#### 3.4.2.3 Extended in-situ inspection

(1) An extended *in-situ* inspection is a procedure used when the original detailed construction drawings are not available. This entails performing inspections as indicated in 3.4.4(1)P.

#### 3.4.2.4 Comprehensive in-situ inspection

(1) A comprehensive *in-situ* inspection is a procedure used when the original detailed construction drawings are not available and when a higher knowledge level is pursued. This entails performing inspections as indicated in 3.4.4(1)P.

### 3.4.3 Materials

#### 3.4.3.1 Destructive and non-destructive testing

(1) Use of non-destructive test methods (e.g., Schmidt hammer test, etc.) should be considered; however such tests should not be used in isolation, but only in conjunction with destructive tests.

#### 3.4.3.2 Limited in-situ testing

(1) A limited programme of *in-situ* testing is a procedure for complementing the information on material properties derived either from standards at the time of construction, or from original design specifications, or from original test reports. This entails performing tests as indicated in 3.4.4(1)P. However, if values from tests are lower than default values in accordance with standards of the time of construction, an extended *in-situ* testing is required.

#### 3.4.3.3 Extended in-situ testing

(1) An extended programme of *in-situ* testing is a procedure for obtaining information when neither the original design specification nor the test reports are



available. This entails performing tests as indicated in 3.4.4(1)P.

### 3.4.3.4 Comprehensive in-situ testing

(1) A comprehensive programme of *in-situ* testing is a procedure for obtaining information when neither the original design specification nor the test reports are available and when a higher knowledge level is pursued. This entails performing tests as indicated in 3.4.4(1)P.

### 3.4.4 Definition of the levels of inspection and testing

(1)P The classification of the levels of inspection and testing depend on the percentage of structural elements that have to be checked for details, as well as on the number of material samples per floor that have to taken for testing.

NOTE The amount of inspection and testing to be used in a country may be found in its National Annex. For ordinary situations the recommended minimum values are given in Table 3.2. There might be cases requiring modifications to increase some of them. These cases will be indicated in the National Annex.

**Table 3.2: Recommended minimum requirements for different levels of inspection and testing.**

	Inspection (of details)	Testing (of materials)
	For each type of primary element (beam, column, wall):	
Level of inspection and testing	Percentage of elements that are checked for details	Material samples per floor
Limited	20	1
Extended	50	2
Comprehensive	80	3

### 3.5 Confidence factors

(1)P To determine the properties of existing materials to be used in the calculation of the capacity, when capacity is to be compared with demand for safety verification, the mean values obtained from *in-situ* tests and from the additional sources of information, shall be divided by the confidence factor, CF, given in Table 3.1 for the appropriate knowledge level (see 2.2.1(5)P).

(2)P To determine the properties to be used in the calculation of the force capacity (strength) of ductile components delivering action effects to brittle components/mechanisms, for use in 4.5.1(1)P(b), the mean value properties of existing materials obtained from *in-situ* tests and from the additional sources of information, shall be multiplied by the confidence factor, CF, given in Table 3.1 for the appropriate knowledge level.

## 4 ASSESSMENT

### 4.1 General

(1) Assessment is a quantitative procedure for checking whether an existing undamaged or damaged building will satisfy the required limit state appropriate to the seismic action under consideration, as specified in **2.1**.

(2)P This Standard is intended for the assessment of individual buildings, to decide on the need for structural intervention and to design the retrofitting measures that may be necessary. It is not intended for the vulnerability assessment of populations or groups of buildings for seismic risk evaluation for various purposes (e.g. for determining insurance risk, for setting risk mitigation priorities, etc.).

(3)P The assessment procedure shall be carried out by means of the general analysis methods specified in EN 1998-1: 2004, **4.3**, as modified in this Standard to suit the specific problems encountered in the assessment.

(4) Whenever possible, the method used should incorporate information of the observed behaviour of the same type of building or similar buildings during previous earthquakes.

### 4.2 Seismic action and seismic load combination

(1)P The basic models for the definition of the seismic motion are those presented in EN 1998-1: 2004, **3.2.2** and **3.2.3**.

(2)P Reference is made in particular to the elastic response spectrum specified in EN 1998-1: 2004, **3.2.2.2**, scaled to the values of the design ground acceleration established for the verification of the different Limit States. The alternative representations allowed in EN 1998-1: 2004, **3.2.3** in terms of either artificial or recorded accelerograms are also applicable.

(3)P In the  $q$ -factor approach (see **2.2.1(4)P**), the design spectrum for linear analysis is obtained from EN 1998-1: 2004, **3.2.2.5**. A value of  $q = 1,5$  and  $2,0$  for reinforced concrete and steel structures, respectively, may be adopted regardless of the structural type. Higher values of  $q$  may be adopted if suitably justified with reference to the local and global available ductility, evaluated in accordance with the relevant provisions of EN 1998-1: 2004.

(4)P The design seismic action shall be combined with the other appropriate permanent and variable actions in accordance with EN 1998-1: 2004, **3.2.4**.

### 4.3 Structural modelling

(1)P Based on information collected as indicated in **3.2**, a model of the structure shall be set up. The model shall be such that the action effects in all structural elements can be determined under the seismic load combination given in **4.2**.

(2)P All provisions of EN 1998-1: 2004 regarding modelling (EN 1998-1: 2004, **4.3.1**) and accidental torsional effects (EN 1998-1: 2004, **4.3.2**) shall be applied without

modifications.

(3) The strength and the stiffness of secondary seismic elements, (see **2.2.1(6)P**) against lateral actions may in general be neglected in the analysis.

(4) Taking into account secondary seismic elements in the overall structural model, however, is advisable if nonlinear analysis is applied. The choice of the elements to be considered as secondary seismic may be varied after the results of a preliminary analysis. In no case the selection of these elements should be such as to change the classification of the structure from non regular to regular, in accordance with the definitions in EN 1998-1: 2004, **4.2.3**.

(5)P Mean values of material properties shall be used in the structural model.

## 4.4 Methods of analysis

### 4.4.1 General

(1) The seismic action effects, to be combined with the effects of the other permanent and variable loads in accordance with the seismic load combination in **4.2(4)P**, may be evaluated using one of the following methods:

- lateral force analysis (linear),
- modal response spectrum analysis (linear),
- non-linear static (pushover) analysis,
- non-linear time history dynamic analysis.
- $q$ -factor approach.

(2)P Except in the  $q$ -factor approach of **2.2.1(4)P** and **4.2(3)P**, the seismic action to be used shall be the one corresponding to the elastic (*i.e.*, un-reduced by the behaviour factor  $q$ ) response spectrum in EN 1998-1: 2004, **3.2.2.2**, or its equivalent alternative representations in EN 1998-1: 2004, **3.2.3**.

(3)P In the  $q$ -factor approach of **2.2.1(4)P** the seismic action is defined in **4.2(3)P**.

(4) Clause **4.3.3.1(5)** of EN1998-1: 2004 applies.

(5) The above-listed methods of analysis are applicable subject to the conditions specified in **4.4.2** to **4.4.5**, with the exception of masonry structures for which procedures accounting for the peculiarities of this construction typology need to be used.

NOTE Complementary information on these procedures may be found in the relevant material-related Informative Annex.

### 4.4.2 Lateral force analysis

(1)P The conditions for this method to be applicable are given in EN 1998-1: 2004, **4.3.3.2.1**, with the addition of the following:

Denoting by  $\rho_i = D_i/C_i$  the ratio between the demand  $D_i$  obtained from the analysis

under the seismic load combination, and the corresponding capacity  $C_i$  for the  $i$ -th ‘ductile’ primary element of the structure (bending moment in moment frames or shear walls, axial force in a bracing  $\overline{AC_i}$  of a braced frame, etc.) and by  $\rho_{\max}$  and  $\rho_{\min}$   $\overline{AC_1}$  the maximum and minimum values of  $\rho_i$ , respectively, over all ‘ductile’ primary elements of the structure with  $\rho_i > 1$ , the ratio  $\rho_{\max}/\rho_{\min}$  does not exceed a maximum acceptable value in the range of 2 to 3. Around beam-column joints the ratio  $\rho_i$  needs to be evaluated only at the sections where plastic hinges are expected to form on the basis of the comparison of the sum of beam flexural capacities to that of columns. **4.3(5)P** applies for the calculation of the capacities  $C_i$ . For the determination of the bending moment capacities  $C_i$  of vertical elements, the value of the axial force may be taken equal to that due to the vertical loads only.

NOTE 1 The value ascribed to this limit of  $\rho_{\max}/\rho_{\min}$  for use in a country (within the range indicated above) may be found in its National Annex. The recommended value is 2,5.

NOTE 2 As an additional condition, the capacity  $C_i$  of the “brittle” elements or mechanism should be larger than the corresponding demand  $D_i$ , evaluated in accordance with **4.5.1(1)P**, **(2)** and **(3)**. Nonetheless, enforcing it as a criterion for the applicability of linear analysis is redundant, because, in accordance with **2.2.2(2)P**, **2.2.3(2)P** and **2.2.4(2)P**, this condition will ultimately be fulfilled in all elements of the assessed or retrofitted structure, irrespective of the method of analysis.

(2)P The method shall be applied as described in EN 1998-1: 2004, **4.3.3.2.2**, **4.3.3.2.3** and **4.3.3.2.4**, except that the ordinate of the response spectrum in expression (4.5) shall be that of the elastic spectrum  $S_c(T_1)$  instead of the design spectrum  $S_d(T_1)$ .

#### 4.4.3 Multi-modal response spectrum analysis

(1)P The conditions of applicability for this method are given in EN 1998-1: 2004, **4.3.3.3.1**, with the addition of the conditions specified in **4.4.2**.

(2)P The method shall be applied as described in EN 1998-1: 2004, **4.3.3.3.2/3**, using the elastic response spectrum  $S_c(T_1)$ .

#### 4.4.4 Nonlinear static analysis

##### 4.4.4.1 General

(1)P Nonlinear static (pushover) analysis is a non-linear static analysis under constant gravity loads and monotonically increasing horizontal loads.

(2)P Buildings not conforming with the criteria of EN 1998-1: 2004, **4.3.3.4.2.1(2)**, **(3)** for regularity in plan shall be analysed using a spatial model.

(3)P For buildings conforming with the regularity criteria of EN 1998-1: 2004, **4.2.3.2** the analysis may be performed using two planar models, one for each main horizontal direction of the building.

##### 4.4.4.2 Lateral loads

(1) At least two vertical distributions of lateral loads should be applied:

- a “uniform” pattern, based on lateral forces that are proportional to mass regardless of elevation (uniform response acceleration)

- a “modal” pattern, proportional to lateral forces consistent with the lateral force distribution determined in elastic analysis
- (2) Lateral loads should be applied at the location of the masses in the model. Accidental eccentricity should be taken into account.

#### **4.4.4.3 Capacity curve**

- (1) The relation between base-shear force and the control displacement (the “capacity curve”) should be determined in accordance with EN 1998-1: 2004, **4.3.3.4.2.3(1), (2)**.

#### **4.4.4.4 Target displacement**

- (1)P Target displacement is defined as in EN 1998-1: 2004, **4.3.3.4.2.6(1)**.

NOTE Target displacement may be determined in accordance with EN 1998-1: 2004, Informative Annex B.

#### **4.4.4.5 Procedure for estimation of torsional and higher mode effects**

- (1)P The procedure given in EN 1998-1: 2004, **4.3.3.4.2.7(1) to (3)** applies for the estimation of torsional effects.
- (2) In buildings that do not meet the criteria in EN1998-1: 2004, **4.3.3.2.1(2)a**, the contributions to the response from modes of vibration higher than the fundamental one in each principal direction should be taken into account.

NOTE The requirement in (2) may be satisfied either by performing a non-linear time-history analysis in accordance with **4.4.5**, or through special versions of the non-linear static analysis procedure that can capture the effects of higher modes on global measures of the response (such as interstorey drifts) to be translated then to estimates of local deformation demands (such as member hinge rotations). The National Annex may contain reference to complementary, non-contradictory information for such procedures.

#### **4.4.5 Non-linear time-history analysis**

- (1)P The procedure given in EN 1998-1: 2004, **4.3.3.4.3(1) to (3)** applies.

#### **4.4.6 $q$ -factor approach**

- (1)P In the  $q$ -factor approach, the method shall be applied as described in EN 1998-1: 2004, **4.3.3.2** or **4.3.3.3**, as appropriate.

#### **4.4.7 Combination of the components of the seismic action**

- (1)P The two horizontal components of the seismic action shall be combined in accordance with EN 1998-1: 2004, **4.3.3.5.1**.
- (2)P The vertical component of the seismic action shall be taken into account in the cases specified in EN 1998-1: 2004, **4.3.3.5.2** and, when appropriate, combined with the horizontal components as indicated in the same clause.

#### 4.4.8 Additional measures for masonry infilled structures

- (1) The provisions of EN 1998-1: 2004, **4.3.6** apply, wherever relevant.

#### 4.4.9 Combination coefficients for variable actions

- (1) The provisions of EN 1998-1: 2004, **4.2.4** apply

#### 4.4.10 Importance classes and importance factors

- (1) The provisions of EN 1998-1: 2004, **4.2.5** apply.

### 4.5 Safety verifications

#### 4.5.1 Linear methods of analysis (lateral force or modal response spectrum analysis)

(1)P “Brittle” components/mechanisms shall be verified with demands calculated by means of equilibrium conditions, on the basis of the action effects delivered to the brittle component/mechanism by the ductile components. In this calculation, each action effect in a ductile component delivered to the brittle component/mechanism under consideration shall be taken equal to:

(a) the value  $D$  obtained from the analysis, if the capacity  $C$  of the ductile component, evaluated using mean values of material properties, satisfies  $\rho = D/C \leq 1$ ,

(b) the capacity of the ductile component, evaluated using mean values of material properties multiplied by the confidence factors, as defined in **3.5**, accounting for the level of knowledge attained, if  $\rho = D/C > 1$ , with  $D$  and  $C$  as defined in (a) above.

(2) In **(1)b** above the capacities of the beam sections around concrete beam-column joints should be computed from expression (5.8) in EN 1998-1: 2004 and those of the column sections around such joints from expression (5.9), using in the right-hand-side of these expressions the value  $\gamma_{Rd} = 1$  and mean values of material properties multiplied by the confidence factors, as defined in **3.5**.

(3) For the calculation of force demands on the “brittle” shear mechanism of walls through **(1)b** above, expression (5.26) in EN1998-1: 2004 may be applied with  $\gamma_{Rd} = 1$  and using as  $M_{Rd}$  the bending moment capacity at the base, evaluated using mean values of material properties multiplied by the confidence factors, as defined in **3.5**.

(4) In **(1)P** to **(3)** above the bending moment capacities  $C_i$  of vertical elements may be based on the value of the axial force due to the vertical loads only.

(5)P The value of the capacity of both ductile and brittle components and mechanisms to be compared to demand in safety verifications, shall be in accordance with **2.2.1(5)P**.

NOTE Information for the evaluation of the capacity of components and mechanisms may be found in the relevant material related Informative Annexes A, B and C.

#### **4.5.2 Nonlinear methods of analysis (static or dynamic)**

(1)P The demands on both “ductile” and “brittle” components shall be those obtained from the analysis performed in accordance with 4.4.4 or 4.4.5, using mean value properties of the materials.

(2)P 4.5.1(5)P applies.

NOTE Information for the evaluation of the capacity of components and mechanisms may be found in the relevant material related Informative Annexes A, B and C.

#### **4.5.3 $q$ -factor approach**

(1)P The values of both demand and capacity of ductile and brittle members shall be in accordance with 2.2.1(4)P, 2.2.3(3)P.

### **4.6 Summary of criteria for analysis and safety verifications**

(1)P Table 4.3 summarises:

- The values of the material properties to be adopted in evaluating both the demand and capacities of the elements for all types of analysis.
- The criteria that shall be followed for the safety verification of both ductile and brittle elements for all types of analysis.

**Table 4.3: Values of material properties and criteria for analysis and safety verifications.**

		Linear Model (LM)		Nonlinear Model		<i>q</i> -factor approach	
		Demand	Capacity	Demand	Capacity	Demand	Capacity
Type of element or mechanism (e/m)	Ductile	Acceptability of Linear Model (for checking of $\rho_i = D_i/C_i$ values):  From analysis. Use mean values of properties in model.		From analysis. Use mean values of properties in model.	$\langle AC_1 \rangle$ In terms of deformation. Use mean values of properties <u>divided</u> by CF. $\langle AC_1 \rangle$	From analysis.	In terms of strength. Use mean values of properties <u>divided</u> by CF and by partial factor.
		Verifications (if LM accepted):  From analysis.					
	Brittle	Verifications (if LM accepted):  If $\rho_i \leq 1$ : from analysis. If $\rho_i > 1$ : from equilibrium with strength of ductile e/m. Use mean values of properties <u>multiplied</u> by CF.			In terms of strength. Use mean values of properties <u>divided</u> by CF and by partial factor	In accordance with the relevant Section of EN1998-1:2004.	



## 5 DECISIONS FOR STRUCTURAL INTERVENTION

### 5.1 Criteria for a structural intervention

#### 5.1.1 Introduction

(1) On the basis of the conclusions of the assessment of the structure and/or the nature and extent of the damage, decisions should be taken for the intervention.

NOTE As in the design of new structures, optimal decisions are pursued, taking into account social aspects, such as the disruption of use or occupancy during the intervention.

(2) This Standard describes the technical aspects of the relevant criteria.

#### 5.1.2 Technical criteria

(1)P The selection of the type, technique, extent and urgency of the intervention shall be based on the structural information collected during the assessment of the building.

(2) The following aspects should be taken into account:

a) All identified local gross errors should be appropriately remedied;

b) In case of highly irregular buildings (both in terms of stiffness and overstrength distributions), structural regularity should be improved as much as possible, both in elevation and in plan;

c) The required characteristics of regularity and resistance can be achieved by either modification of the strength and/or stiffness of an appropriate number of existing components, or by the introduction of new structural elements;

d) Increase in the local ductility supply should be effected where required;

e) The increase in strength after the intervention should not reduce the available global ductility;

f) Specifically for masonry structures: non-ductile lintels should be replaced, inadequate connections between floor and walls should be improved, out-of-plane horizontal thrusts against walls should be eliminated.

#### 5.1.3 Type of intervention

(1) An intervention may be selected from the following indicative types:

a) Local or overall modification of damaged or undamaged elements (repair, strengthening or full replacement), considering the stiffness, strength and/or ductility of these elements;

b) Addition of new structural elements (e.g. bracings or infill walls; steel, timber or reinforced concrete belts in masonry construction; etc);

c) Modification of the structural system (elimination of some structural joints;

widening of joints; elimination of vulnerable elements; modification into more regular and/or more ductile arrangements)<sup>1</sup>;

- d) Addition of a new structural system to sustain some or all of the entire seismic action;
- e) Possible transformation of existing non-structural elements into structural elements;
- f) Introduction of passive protection devices through either dissipative bracing or base isolation;
- g) Mass reduction;
- h) Restriction or change of use of the building;
- i) Partial demolition;

(2) One or more types in combination may be selected. In all cases, the effect of structural modifications on the foundation should be taken into account.

(3)P If base isolation is adopted, the provisions contained in EN 1998-1: 2004, **10** shall be followed.

#### **5.1.4 Non-structural elements**

1(P) Decisions regarding repair or strengthening of non-structural elements shall also be taken whenever, in addition to functional requirements, the seismic behaviour of these elements may endanger the life of inhabitants or affect the value of goods stored in the building.

(2) In such cases, full or partial collapse of these elements should be avoided by means of:

- a) Appropriate connections to structural elements (see EN1998-1: 2004, **4.3.5**);
- b) Increasing the resistance of non-structural elements (see EN 1998-1: 2004, **4.3.5**);
- c) Taking measures of anchorage to prevent possible falling out of parts of these elements.

(3) The possible consequences of these provisions on the behaviour of structural elements should be taken into account.

#### **5.1.5 Justification of the selected intervention type**

(1)P In all cases, the documents relating to retrofit design shall include the justification of the type of intervention selected and the description of its expected effect on the structural response.

---

<sup>1</sup> This is for instance the case when vulnerable low shear-ratio columns or entire soft storeys are transformed into more ductile arrangements; similarly, when overstrength irregularities in elevation, or in-plan eccentricities are reduced by modifying the structural system.

- (2) This justification should be made available to the owner.

## 6 DESIGN OF STRUCTURAL INTERVENTION

### 6.1 Retrofit design procedure

(1)P The retrofit design procedure shall include the following steps:

- a) Conceptual design,
- b) Analysis,
- c) Verifications.

(2)P The conceptual design shall cover the following:

- (i) Selection of techniques and/or materials, as well as of the type and configuration of the intervention.
- (ii) Preliminary estimation of dimensions of additional structural parts.
- (iii) Preliminary estimation of the modified stiffness of the retrofitted elements.

(3)P The methods of analysis of the structure specified in 4.4 shall be used, taking into account the modified characteristics of the building.

(4)P Safety verifications shall be carried out in general in accordance with 4.5, for both existing, modified and new structural elements. For existing materials, mean values from in-situ tests and any additional sources of information shall be used in the safety verification, modified by the confidence factor CF, as specified in 3.5. However, for new or added materials nominal properties shall be used, without modification by the confidence factor CF.

NOTE Information on the capacities of existing and new structural elements may be found in the relevant material-related Informative Annex A, B or C.

(5)P In case the structural system, comprising both existing and new structural elements, can be made to fulfill the requirements of EN1998-1: 2004, the verifications may be carried out in accordance with the provisions therein.

## ANNEX A (Informative)

### REINFORCED CONCRETE STRUCTURES

#### A.1 Scope

(1) This Annex contains specific information for the assessment of reinforced concrete buildings in their present state, and for their upgrading, when necessary.

#### A.2 Identification of geometry, details and materials

##### A.2.1 General

(1) The following aspects should be carefully examined:

- i. Physical condition of reinforced concrete elements and presence of any degradation, due to carbonation, steel corrosion, etc.
- ii. Continuity of load paths between lateral resisting elements.

##### A.2.2 Geometry

(1) The collected data should include the following items:

- i. Identification of the lateral resisting systems in both directions.
- ii. Orientation of one-way floor slabs.
- iii. Depth and width of beams, columns and walls.
- iv. Width of flanges in T-beams.
- v. Possible eccentricities between beams and columns axes at joints.

##### A.2.3 Details

(1) The collected data should include the following items:

- i. Amount of longitudinal steel in beams, columns and walls.
- ii. Amount and detailing of confining steel in critical regions and in beam-column joints.
- iii. Amount of steel reinforcement in floor slabs contributing to the negative resisting bending moment of T-beams.
- iv. Seating lengths and support conditions of horizontal elements.

- v. Depth of concrete cover.
- vi. Lap-splices for longitudinal reinforcement.

#### A.2.4 Materials

- (1) The collected data should include the following items:
- i. Concrete strength.
  - ii. Steel yield strength, ultimate strength and ultimate strain.

### A.3 Capacity models for assessment

#### A.3.1 Introduction

- (1) The provisions given in this clause apply to both primary and secondary seismic elements.
- (2) Classification of components/mechanisms:
- i. “ductile”: beam, columns and walls under flexure with and without axial force,
  - ii. “brittle”: shear mechanism of beams, columns, walls and joints.

#### A.3.2 Beam, columns and walls under flexure with and without axial force

##### A.3.2.1 Introduction

(1) The deformation capacity of beams, columns and walls, to be verified in accordance with 2.2.2(2)P, 2.2.3(2)P, 2.2.4(2)P, is defined in terms of the chord rotation  $\theta$ , *i.e.*, of the angle between the tangent to the axis at the yielding end and the chord connecting that end with the end of the shear span ( $L_V = M/V =$  moment/shear at the end section), *i.e.*, the point of contraflexure. The chord rotation is also equal to the element drift ratio, *i.e.*, the deflection at the end of the shear span with respect to the tangent to the axis at the yielding end, divided by the shear span.

##### A.3.2.2 Limit State of near collapse (NC)

(1) The value of the total chord rotation capacity (elastic plus inelastic part) at ultimate,  $\theta_u$ , of concrete members under cyclic loading may be calculated from the following expression:

$$\theta_{um} = \frac{1}{\gamma_{el}} 0,016 \cdot (0,3^v) \left[ \frac{\max(0,01; \omega)}{\max(0,01; \omega)} f_c \right]^{0,225} \left( \min \left( 9; \frac{L_V}{h} \right) \right)^{0,35} 25^{\left( \alpha_{ps} \frac{f_{yw}}{f_c} \right)} (1,25^{100 \rho_d}) \quad (\text{A.1})$$

where:

$\gamma_{el}$  is equal to 1,5 for primary seismic elements and to 1,0 for secondary seismic

elements (as defined in 2.2.1(6)P),

$h$  is the depth of cross-section,

$L_V = M/V$  is the ratio moment/shear at the end section,

$\nu = N / bhf_c$  ( $b$  width of compression zone,  $N$  axial force positive for compression),

$\omega, \omega'$  is the mechanical reinforcement ratio of the tension (including the web reinforcement) and compression, respectively, longitudinal reinforcement,

$f_c$  and  $f_{yw}$  are the concrete compressive strength (MPa) and the stirrup yield strength (MPa), respectively, directly obtained as mean values from *in-situ* tests, and from the additional sources of information, appropriately divided by the confidence factors, as defined in 3.5(1)P and Table 3.1, accounting for the level of knowledge attained,

$\rho_{sx} = A_{sx}/b_w s_h =$  ratio of transverse steel parallel to the direction  $x$  of loading ( $s_h =$  stirrup spacing),

$\rho_d$  is the steel ratio of diagonal reinforcement (if any), in each diagonal direction,

$\alpha$  is the confinement effectiveness factor, that may be taken equal to:

$$\alpha = \left(1 - \frac{s_h}{2b_o}\right) \left(1 - \frac{s_h}{2h_o}\right) \left(1 - \frac{\sum b_i^2}{6h_o b_o}\right) \quad (\text{A.2})$$

where:

$b_o$  and  $h_o$  is the dimension of confined core to the centreline of the hoop,

$b_i$  is the centerline spacing of longitudinal bars (indexed by  $i$ ) laterally restrained by a stirrup corner or a cross-tie along the perimeter of the cross-section.

In walls the value given by  $\overline{\text{AC1}}$  expression (A.1) is multiplied by 0,58.  $\overline{\text{AC1}}$

If cold-worked brittle steel is used the total chord rotation capacity above is divided by 1,6.

(2) The value of the plastic part of the chord rotation capacity of concrete members under cyclic loading may be calculated from the following expression:

$$\overline{\text{AC1}} \theta_{um}^{pl} = \theta_{um} - \theta_y = \frac{1}{\gamma_{el}} 0,0145 \cdot (0,25^\nu) \left[ \frac{\max(0,01; \omega')}{\max(0,01; \omega)} \right]^{0,3} \cdot f_c^{0,2} \cdot \left( \min \left( 9; \frac{L_V}{h} \right) \right)^{0,35} 25^{\left( \alpha \rho_{sx} \frac{f_{yw}}{f_c} \right)} (1,275^{1,00 \rho_d}) \quad (\text{A.3}) \overline{\text{AC1}}$$

where the chord rotation at yielding,  $\theta_y$ , should be calculated in accordance with A.3.2.4,  $\gamma_{el}$  is equal to 1,8 for primary seismic elements and to 1,0 for secondary seismic ones and all other variables are defined as for expression (A.1), .

In walls the value given by expression (A.3) is multiplied by 0,6.

If cold-worked brittle steel is used, the plastic part of the chord rotation capacity is divided by 2.

(3) In members without detailing for earthquake resistance the values given by expressions  $\overline{\text{AC1}}$  (A.1) and (A.3) are divided by  $1.2 \overline{\text{AC1}}$ .

(4) (1) and (2) apply to members with deformed (high bond) longitudinal bars without lapping in the vicinity of the end region where yielding is expected. If deformed longitudinal bars have straight ends lapped starting at the end section of the member - as is often the case in columns and walls with lap-splicing starting at floor level - expressions (A.1) and (A.3) should be applied with the value of the compression reinforcement ratio,  $\omega'$ , doubled over the value applying outside the lap splice. Moreover, if the lap length  $l_o$  is less than  $l_{ou,min}$ , the plastic part of the chord rotation capacity given in (2) should be multiplied by  $l_o/l_{ou,min}$ , while the value of the chord rotation at yielding,  $\theta_y$ , added to it to obtain the total chord rotation capacity, should account for the effect of the lapping in accordance with **A.3.2.4(3)**. The value of  $l_{ou,min}$  is  $l_{ou,min} = d_{bL} f_{yL} / [(1,05 + 14,5 \alpha_1 \rho_{sx} f_{yw} / f_c) \sqrt{f_c}]$ ,

where:

$d_{bL}$  is the diameter of the lapped bars

$f_{yL}$  is the mean value of the yield strength of the lapped bars (MPa) from *in-situ* tests and from the additional sources of information, multiplied by the corresponding confidence factor, as defined in 3.5 and Table 3.1, accounting for the level of knowledge attained (see **3.5(2)P**).

$f_c, f_{yw}$  and  $\rho_{sx}$  as defined in (1), and

$$\alpha_1 = (1 - s_h / (2b_o))(1 - s_h / (2h_o)) n_{restr} / n_{tot}, \text{ with}$$

- $n_{restr}$ : number of lapped longitudinal bars laterally restrained by a stirrup corner or a cross-tie, and
- $n_{tot}$ : total number of lapped longitudinal bars along the cross-section perimeter.

(5) In members with smooth (plain) longitudinal bars without lapping in the vicinity of the end region where yielding is expected, the total chord rotation capacity may be taken equal to the value calculated in accordance with (1)  $\overline{\text{AC1}}$  multiplied by 0,8, while the plastic part of the chord rotation capacity may be taken to be equal to that calculated in accordance with (2) multiplied by 0,75 (with these factors including the reduction factor 1,2 of (3) accounting for the lack  $\overline{\text{AC1}}$  of detailing for earthquake resistance). If the longitudinal bars are lapped starting at the end section of the member and their ends are provided with standard hooks and a lap length  $l_o$  of at least  $15d_{bL}$ , the chord rotation capacity of the member may be calculated as follows:

- In expressions (A.1), (A.3) the shear span  $L_V$  (ratio  $M/V$  - moment/shear - at the end section) is reduced by the lap length  $l_o$ , as the ultimate condition is controlled by the region right after the end of the lap.
- The total chord rotation capacity may be taken equal to the value calculated in  $\overline{\text{AC1}}$  accordance with (1) and (3) multiplied by  $0,019 (10 + \min(40, l_o / d_{bL}))$ , while the  $\overline{\text{AC1}}$



plastic part of the chord rotation capacity may be taken equal to that calculated in **AC1** accordance with **(2)** and **(3)** multiplied by  $0,019 \min(40, l_o/d_{bL})$ . **AC1**

(6) For the evaluation of the ultimate chord rotation capacity an alternative expression may be used:

$$\theta_{um} = \frac{1}{\gamma_{el}} \left( \theta_y + (\phi_u - \phi_y) L_{pl} \left( 1 - \frac{0,5L_{pl}}{L_V} \right) \right) \quad (\text{A.4})$$

where

$\theta_y$  is the chord rotation at yield as defined by expressions (A.10) or (A.11),

$\phi_u$  is the ultimate curvature at the end section,

$\phi_y$  is the yield curvature at the end section.

The value of the length  $L_{pl}$  of the plastic hinge depends on how the enhancement of strength and deformation capacity of concrete due to confinement is taken into account in the calculation of the ultimate curvature of the end section,  $\phi_u$ .

(7) If the ultimate curvature of the end section  $\phi_u$ , under cyclic loading is calculated with:

(a) the ultimate strain of the longitudinal reinforcement,  $\varepsilon_{su}$ , taken equal to:

- the minimum values given in EN 1992-1-1, Table C.1 for the characteristic strain at maximum force,  $\varepsilon_{uk}$ , for steel Classes A or B,
- 6% for steel Class C, and

(b) the confinement model in EN 1992-1-1: 2004, **3.1.9**, with effective lateral confining stress  $\sigma_2$  taken equal to  $\alpha \rho_{sx} f_{yw}$ , where  $\rho_{sx}$ ,  $f_{yw}$  and  $\alpha$  have been defined in **(1)**,

then, for members with detailing for earthquake resistance and without lapping of longitudinal bars in the vicinity of the section where yielding is expected,  $L_{pl}$  may be calculated from the following expression:

$$L_{pl} = 0,1L_V + 0,17h + 0,24 \frac{d_{bL} f_y (\text{MPa})}{\sqrt{f_c (\text{MPa})}} \quad (\text{A.5})$$

where  $h$  is the depth of the member and  $d_{bL}$  is the (mean) diameter of the tension reinforcement.

(8) If the ultimate curvature of the end section,  $\phi_u$ , under cyclic loading is calculated with:

- (a) the ultimate strain of the longitudinal reinforcement,  $\varepsilon_{su}$ , taken as in **(7)**a, and
- (b) a confinement model which represents better than the model in EN 1992-1-1: 2004, **3.1.9** the improvement of  $\phi_u$  with confinement under cyclic loading; namely a model where:

- the strength of confined concrete is evaluated from:

$$f_{cc} = f_c \left[ 1 + 3,7 \left( \frac{\alpha \rho_{sx} f_{yw}}{f_c} \right)^{0,86} \right] \quad (\text{A.6})$$

- the strain at which the strength  $f_{cc}$  takes place is taken to increase over the value  $\varepsilon_{c2}$  of unconfined concrete as:

$$\varepsilon_{cc} = \varepsilon_{c2} \left[ 1 + 5 \left( \frac{f_{cc}}{f_c} - 1 \right) \right] \quad (\text{A.7})$$

- and the ultimate strain of the extreme fibre of the compression zone is taken as:

$$\varepsilon_{cu} = 0,004 + 0,5 \frac{\alpha \rho_{sx} f_{yw}}{f_{cc}} \quad (\text{A.8})$$

where:

$\alpha$ ,  $f_{yw}$  and  $\rho_{sx}$  are as defined in (1) and (7) and  $f_{cc}$  is the concrete strength, as enhanced by confinement,

then, for members with detailing for earthquake resistance and no lapping of longitudinal bars near the section where yielding is expected,  $L_{pl}$  may be calculated from the following expression:

$$L_{pl} = \frac{L_V}{30} + 0,2h + 0,11 \frac{d_{bL} f_y (\text{MPa})}{\sqrt{f_c (\text{MPa})}} \quad (\text{A.9})$$

(9) If the confinement model in EN1992-1-1: 2004 **3.1.9** is adopted in the calculation of the ultimate curvature of the end section,  $\phi_u$ , and the value of  $L_{pl}$  from expression (A.5) is used in expression (A.4), then the factor  $\gamma_{cl}$  therein may be taken equal to 2 for primary seismic and to 1,0 for secondary seismic elements. If the confinement model given by expressions (A.6) to (A.8) is used instead, together with expression (A.9), then the value of the factor  $\gamma_{cl}$  may be taken equal to 1,7 for primary seismic elements and to 1,0 for secondary seismic ones.

NOTE The values of the total chord rotation capacity calculated in accordance with (1) and (2) above (taking into account (3) to (5)) are normally very similar. Expression (A.1) is more convenient when calculations and demands are based on total chord rotations, whilst expression (A.3) is better suited for those cases when calculations and demands are based on the plastic part of chord rotations; moreover, (4) gives the chord rotation capacity of members with deformed longitudinal bars and straight ends lapped starting at the end section only in terms of expression (A.3). Expression (A.4) with  $\gamma_{cl}=1$  yields fairly similar results when used with either (7) or (8), but differences with the predictions of (1) or (2) are larger. The scatter of test results with respect to those of expression (A.4) for  $\gamma_{cl}=1$  used with (8) is less than when it is used with (7). This is reflected in the different values of  $\gamma_{cl}$  specified in (1), (2) and (9), for primary seismic elements, as  $\gamma_{cl}$  is meant to convert mean values to mean-minus-one-standard-deviation ones. Finally, the effects of lack of detailing for earthquake resistance and of lap splicing in the plastic hinge zone are specified in (3) to (5) only in connection with expressions (A.1) and (A.3).

(10) Existing walls conforming to the definition of “large lightly reinforced walls” of

EN1998-1: 2004, can be verified in accordance with EN1992-1-1: 2004.

### A.3.2.3 Limit State of Significant Damage (SD)

(1) The chord rotation capacity corresponding to significant damage  $\theta_{SD}$  may be assumed to be 3/4 of the ultimate chord rotation  $\theta_u$  given in A.3.2.2.

### A.3.2.4 Limit State of Damage Limitation (DL)

(1) The capacity for this limit state used in the verifications is the yielding bending moment under the design value of the axial load.

(2) In case the verification is carried out in terms of deformations the corresponding capacity is given by the chord rotation at yielding  $\theta_y$ , evaluated as:

For beams and columns:

$$\boxed{\text{AC1}} \theta_y = \phi_y \frac{L_V + a_V z}{3} + 0,0014 \left( 1 + 1,5 \frac{h}{L_V} \right) + \frac{\varepsilon_y}{d - d'} \frac{d_{bL} f_y}{6\sqrt{f_c}} \boxed{\text{AC1}} \quad (\text{A.10a})$$

For walls of rectangular, T- or barbelled section:

$$\boxed{\text{AC1}} \theta_y = \phi_y \frac{L_V + a_V z}{3} + 0,0013 + \frac{\varepsilon_y}{d - d'} \frac{d_{bL} f_y}{6\sqrt{f_c}} \boxed{\text{AC1}} \quad (\text{A.11a})$$

or from the alternative (and equivalent) expressions for beams and columns:

$$\boxed{\text{AC1}} \theta_y = \phi_y \frac{L_V + a_V z}{3} + 0,0014 \left( 1 + 1,5 \frac{h}{L_V} \right) + \phi_y \frac{d_{bL} f_y}{8\sqrt{f_c}} \boxed{\text{AC1}} \quad (\text{A.10b})$$

and for walls of rectangular, T- or barbelled section:

$$\boxed{\text{AC1}} \theta_y = \phi_y \frac{L_V + a_V z}{3} + 0,0013 + \phi_y \frac{d_{bL} f_y}{8\sqrt{f_c}} \boxed{\text{AC1}} \quad (\text{A.11b})$$

where:

$\phi_y$  is the yield curvature of the end section,

$\boxed{\text{AC1}} a_V z \boxed{\text{AC1}}$  is the tension shift of the bending moment diagram (see EN 1992-1-1: 2004, 9.2.1.3(2)), with

$z$  length of internal lever arm, taken equal to  $d - d'$  in beams, columns, or walls with barbelled or T-section, or to  $0,8h$  in walls with rectangular section, and

$\boxed{\text{AC1}} a_V = 1$  if shear cracking is expected to precede flexural yielding at the end section (i.e. when the yield moment at the end section,  $M_y$ , exceeds the product of  $L_V$  times the shear resistance of the member considered without shear reinforcement,  $V_{R,c}$ , taken in accordance with EN 1992-1-1: 2004, 6.2.2(1)); otherwise, (i.e. if  $M_y < L_V V_{R,c}$ )  $a_V = 0$ ,  $\boxed{\text{AC1}}$

$f_y$  and  $f_c$  are the steel yield stress and the concrete strength, respectively, as defined for expression (A.1), both in MPa,

$\varepsilon_y$  is equal to  $f_y/E_s$ ,

$d$  and  $d'$  are the depths to the tension and compression reinforcement, respectively, and

$d_{bL}$  is the (mean) diameter of the tension reinforcement.

The first term in expressions (A.10), (A.11) accounts for the flexural contribution. The second term represents the contribution of shear deformation and the third anchorage slip of bars.

NOTE The two alternative sets of expressions: (A.10a), (A.11a) on one hand and (A.10b), (A.11b) on the other are practically equivalent. Expressions: (A.10a), (A.11a) are more rational but expressions: (A.10b), (A.11b) are more convenient and their use may be overall more convenient, as the calculation of  $\phi_y$  may be difficult and more prone to errors.

(3) (1) and (2) apply to members with longitudinal bars without lapping in the vicinity of the end region where yielding is expected. If longitudinal bars are deformed with straight ends lapped starting at the end section of the member (as in columns and walls with lap-splicing starting at floor level), the yield moment  $M_y$  and the yield curvature  $\phi_y$  in expressions (A.10), (A.11) should be computed with a compression reinforcement ratio doubled over the value applying outside the lap splice. If the straight lap length  $l_o$  is less than  $l_{oy,min}=0,3d_{bL}f_{yL}/\sqrt{f_c}$ , where  $d_{bL}$  is the diameter of the lapped bars,  $f_{yL}$  (in MPa) is the mean value of the steel yield strength of lapped bars from *in-situ* tests and from the additional sources of information, multiplied by the confidence factor, as defined in 3.5 and Table 3.1, accounting for the level of knowledge attained (see 3.5(2)P) and  $f_c$  (in MPa) is as defined for expression (A.1), then:

- $M_y$  and  $\phi_y$  should be calculated with the yield stress,  $f_y$ , multiplied by  $l_o/l_{oy,min}$ ,
- the yield strain,  $\varepsilon_y$ , in the last term of expressions (A.10a), (A.11a) should be multiplied by  $l_o/l_{oy,min}$ ,
- the second term in expressions (A.10), (A.11) should be multiplied by the ratio of the value of yield moment  $M_y$  as modified to account for the lap splicing, to the yield moment outside the lap splice,
- in order to determine whether term  $\alpha_{VZ}$  contributes to the first term in expressions (A.10), (A.11) with  $\alpha_V=1$ , the product  $L_V V_{R,c}$  is compared to the yield moment  $M_y$  as modified for the effect of the lapping.

(4) (1) and (2) may be considered to apply also to members with smooth longitudinal bars, even when their ends, supplied with standard hooks, are lapped starting at the end section of the member (as in columns and walls with lap-splicing starting at floor level), provided that the lap length  $l_o$  is at least equal to  $15d_{bL}$ .

(5) If the verification is carried out in terms of deformations, deformation demands should be obtained from an analysis of a structural model in which the stiffness of each element is taken to be equal to the mean value of  $M_y L_V / 3 \theta_y$ , at the two ends of the element. In this calculation the shear span at the end section,  $L_V$ , may be taken to be equal to half the element length.

### A.3.3 Beams, columns and walls: shear

#### A.3.3.1 Limit State of Near Collapse (NC)

(1) The cyclic shear resistance,  $V_R$ , decreases with the plastic part of ductility demand, expressed in terms of ductility factor of the transverse deflection of the shear span or of the chord rotation at member end:  $\mu_{\Delta}^{pl} = \mu_{\Delta} - 1$ . For this purpose  $\mu_{\Delta}^{pl}$  may be calculated as the ratio the plastic part of the chord rotation,  $\theta$ , normalized to the chord rotation at yielding,  $\theta_y$ , calculated in accordance with A.3.2.4(2) to (4).

The following expression may be used for the shear strength, as controlled by the stirrups, accounting for the above reduction (with units: MN and meters):

$$V_R = \frac{1}{\gamma_{el}} \left[ \frac{h-x}{2L_V} \min(N; 0,55A_c f_c) + (1 - 0,05 \min(5; \mu_{\Delta}^{pl})) \cdot \left[ 0,16 \max(0,5; 100\rho_{tot}) \left( 1 - 0,16 \min\left(5; \frac{L_V}{h}\right) \right) \sqrt{f_c} A_c + V_w \right] \right] \quad (\text{A.12})$$

where:

$\gamma_{el}$  is equal to 1,15 for primary seismic elements and 1,0 for secondary seismic elements (as defined in 2.2.1(6)P),

$h$  is the depth of cross-section (equal to the diameter  $D$  for circular sections),

$x$  is the compression zone depth,

$N$  is the compressive axial force (positive, taken as being zero for tension),

$L_V = M/V$  is the ratio moment/shear at the end section,

$A_c$  is the cross-section area, taken as being equal to  $b_w d$  for a cross-section with a rectangular web of width (thickness)  $b_w$  and structural depth  $d$ , or to  $\pi D_c^2/4$  (where  $D_c = D - 2c - 2d_{bw}$ , is the diameter of the concrete core to the inside of the hoops, with  $D$  and  $c$  as defined in b) below and  $d_{bw}$  the diameter of the transverse reinforcement) for circular sections,

$f_c$  is the concrete compressive strength, as defined for expression (A.1); for primary seismic elements  $f_c$  should further be divided by the partial factor for concrete in accordance with EN1998-1: 2004, 5.2.4,

$\rho_{tot}$  is the total longitudinal reinforcement ratio,

$V_w$  is the contribution of transverse reinforcement to shear resistance, taken as being equal to:

a) for cross-sections with rectangular web of width (thickness)  $b_w$ :

$$V_w = \rho_w b_w z f_{yw} \quad (\text{A.13})$$

where:

$\rho_w$  is the transverse reinforcement ratio,

$z$  is the length of the internal lever arm, as specified in **A.3.2.4(2)**, and  
 $f_{yw}$  is the yield stress of the transverse reinforcement as defined for expression (A.1); for primary seismic elements  $f_{yw}$  should further be divided by the partial factor for steel in accordance with EN 1998-1: 2004, **5.2.4**;

b) for circular cross-sections:

$$V_w = \frac{\pi}{2} \frac{A_{sw}}{s} f_{yw} (D - 2c) \quad (\text{A.14})$$

where:

$D$  is the diameter of the section,  
 $A_{sw}$  is the cross-sectional area of a circular stirrup,  
 $s$  is the centerline spacing of stirrups,  
 $f_{yw}$  is as defined in (a) above, and  
 $c$  is the concrete cover.

(2) The shear strength of a concrete wall,  $V_R$ , may not be taken greater than the value corresponding to failure by web crushing,  $V_{R,max}$ , which under cyclic loading may be calculated from the following expression (with units: MN and meters):

$$V_{R,max} = \frac{0,85(1 - 0,06 \min(5; \mu_{\Delta}^{pl}))}{\gamma_{el}} \left( 1 + 1,8 \min(0,15; \frac{N}{A_c f_c}) \right) (1 + 0,25 \max(1,75; 100 \rho_{tot})) \left( 1 - 0,2 \min(2; \frac{L_v}{h}) \right) \sqrt{f_c} b_w z \quad (\text{A.15})$$

where  $\gamma_{el} = 1,15$  for primary seismic elements and  $1,0$  for secondary seismic ones,  $f_c$  is in MPa,  $b_w$  and  $z$  are in meters and  $V_{R,max}$  in MN, and all other variables are as defined in **(1)**.

The shear strength under cyclic loading as controlled by web crushing prior to flexural yielding is obtained from expression (A.15) for  $\mu_{\Delta}^{pl} = 0$ .

(3) If in a concrete column the shear span ratio,  $L_v/h$ , at the end section with the maximum of the two end moments less or equal to  $2,0$ , its shear strength,  $V_R$ , should not be taken greater than the value corresponding to failure by web crushing along the diagonal of the column after flexural yielding,  $V_{R,max}$ , which under cyclic loading may be calculated from the expression (with units: MN and meters):

$$V_{R,max} = \frac{4/7(1 - 0,02 \min(5; \mu_{\Delta}^{pl}))}{\gamma_{el}} \left( 1 + 1,35 \frac{N}{A_c f_c} \right) (1 + 0,45(100 \rho_{tot})) \sqrt{\min(40; f_c)} b_w z \sin 2\delta \quad (\text{A.16})$$

where:

$\delta$  is the angle between the diagonal and the axis of the column ( $\tan \delta = h/2L_v$ ),  
and all other variables are as defined in **(3)**.

(4) The minimum of the shear resistance calculated in accordance with EN1992-1-1: 2004 or by means of expressions (A.12)-(A.16) should be used in the assessment.

(5) Mean material properties from *in-situ* tests and from additional sources of

information, should be used in the calculations.

(6) For primary seismic elements, mean material strengths in addition to being divided by the appropriate confidence factors based on the Knowledge Level, they should be divided by the partial factors for materials in accordance with EN1998-1: 2004, **5.2.4**.

#### **A.3.3.2 Limit State of Significant Damage (SD) and of Damage Limitation (DL)**

(1) The verification against the exceedance of these two LS is not required, unless these two LS are the only ones to be checked. In that case **A.3.3.1** applies.

### **A.3.4 Beam-column joints**

#### **A.3.4.1 LS of Near Collapse (NC)**

(1) The shear demand on the joints is evaluated in accordance with EN 1998-1: 2004, **5.5.2.3**.

(2) The shear capacity of the joints is evaluated in accordance with EN 1998-1: 2004, **5.5.3.3**.

(3) **A.3.3.1(5)** and **(6)** apply to joints of primary seismic elements with other elements,

#### **A.3.4.2 Limit State of Significant Damage (SD) and of Damage Limitation (DL)**

(1) The verification against the exceedance of these two LS is not required, unless these two LS are the only ones to be checked. In that case, **A.3.4.1** applies.

## **A.4 Capacity models for strengthening**

### **A.4.1 General**

(1) The rules for member strength and deformation capacities given in the following clauses for strengthened members refer to the capacities at the LS of NC in **A.3.2.2** and **A.3.3.1** prior to the application of the overall factor  $\gamma_{cl}$ . The  $\gamma_{cl}$  factors specified in **A.3.2.2** and **A.3.3.1** should be applied on the strength and deformation capacities of the retrofitted member, as determined in accordance with the following clauses.

(2) The partial factors to be applied to the new steel and concrete used for the retrofitting are those of EN1998-1: 2004, **5.2.4**, and to new structural steel used for the retrofitting are those of EN1998-1: 2004, **6.1.3(1)P**.

### **A.4.2 Concrete jacketing**

#### **A.4.2.1 Introduction**

(1) Concrete jackets are applied to columns and walls for all or some of the

following purposes:

- increasing the bearing capacity,
- increasing the flexural and/or shear strength,
- increasing the deformation capacity,
- improving the strength of deficient lap-splices.

(2) The thickness of the jackets should allow for placement of both longitudinal and transverse reinforcement with an adequate cover.

(3) When jackets aim at increasing flexural strength, longitudinal bars should be continued to the adjacent storey through holes piercing the slab, while horizontal ties should be placed in the joint region through horizontal holes drilled in the beams. Ties may be omitted in the case of fully confined interior joints.

(4) When only shear strength and deformation capacity increases are of concern, jointly with a possible improvement of lap-splicing, then jackets should be terminated (both concreting and reinforcement) leaving a gap with a slab of the order of 10 mm.

#### A.4.2.2 Enhancement of strength, stiffness and deformation capacity

(1) For the purpose of evaluating strength and deformation capacities of jacketed elements, the following approximate simplifying assumptions may be made:

- the jacketed element behaves monolithically, with full composite action between old and new concrete,
- the fact that axial load is originally applied to the old column alone is disregarded, and the full axial load is assumed to act on the jacketed element,
- the concrete properties of the jacket are assumed to apply over the full section of the element.

(2) The following relations may be assumed to hold between the values of  $V_R$ ,  $M_y$ ,  $\theta_y$ , and  $\theta_u$ , calculated under the assumptions above and the values  $V_R^*$ ,  $M_y^*$ ,  $\theta_y^*$ , and  $\theta_u^*$  to be adopted in the capacity verifications:

- For  $V_R^*$  :

$$V_R^* = 0,9V_R \quad (\text{A.17})$$

- For  $M_y^*$ :

$$M_y^* = M_y \quad (\text{A.18})$$

- For  $\theta_y^*$ :

AC1 Text deleted AC1

$$\theta_y^* = 1,05\theta_y \quad (\text{A.19a})$$



AC1 Text deleted AC1

– For  $\theta_u^*$ :

$$\theta_u^* = \theta_u \quad (\text{A.20})$$

(3) The values of  $\theta_u^*$ ,  $\theta_y^*$ ,  $M_y^*$  of the jacketed member, to be used in comparisons to demands in safety verifications, should be computed on the basis of: (a) the mean value strength of the existing steel as directly obtained from *in-situ* tests and from additional sources of information, appropriately divided by the confidence factor in 3.5, accounting for the level of knowledge attained; and (b) the nominal strength of the added concrete and reinforcement.

(4) The value of  $V_R^*$  of the jacketed member, to be compared to the demand in safety verifications, should be computed on the basis of: (a) the mean value strength of the existing steel as directly obtained from *in-situ* tests and from the additional sources of information, divided by the appropriate confidence factor in 3.5, accounting for the level of knowledge attained; and (b) the nominal strength of the added concrete and reinforcement. In primary seismic elements the mean value strength of the existing steel and the nominal strength of the added materials should be divided by the partial factors for steel and concrete in accordance with EN 1998-1: 2004, 5.2.4.

(5) The value of  $M_y^*$  of jacketed members that deliver action effects to brittle components/mechanisms, for use in 4.5.1(1)P(b), should be computed on the basis of: (a) the mean value strength of the existing steel as directly obtained from *in-situ* tests, and from additional sources of information, appropriately multiplied by the confidence factor in 3.5, accounting for the level of knowledge attained; and (b) the nominal strength of the added concrete and reinforcement (see 3.5(2)P).

### A.4.3 Steel jacketing

#### A.4.3.1 Introduction

(1) Steel jackets are mainly applied to columns for the purpose of: increasing shear strength and improving the strength of deficient lap-splices. They may also be considered to increase ductility through confinement.

(2) Steel jackets around rectangular columns are usually built up of four corner angles to which either continuous steel plates, or thicker discrete horizontal steel straps, are welded. Corner angles may be epoxy-bonded to the concrete, or just made to adhere to it without gaps along the entire height. Straps may be pre-heated just prior to welding, in order to provide afterwards some positive confinement on the column.

#### A.4.3.2 Shear strength

(1) The contribution of the jacket to shear strength may be assumed as additive to existing strength, provided the jacket remains well within the elastic range. This

condition is necessary for the jacket to be able to control the width of internal cracks and to ensure the integrity of the concrete, thus allowing the original shear resisting mechanism to continue to operate.

(2) If only 50% of the steel yield strength of the jacket is used, the expression for the additional shear  $V_j$  carried by the jacket is:

$$\boxed{\text{AC1}} V_j = 0,5h \frac{2t_j b}{s} f_{y,j,d} \cdot (\cot \theta + \cot \beta) \cdot \sin \beta \quad \boxed{\text{AC1}} \quad (\text{A.21})$$

where:

- $\boxed{\text{AC1}} h$  is the depth of the cross-section,  
 $t_j$  is the thickness of the steel straps,  
 $b$  is the width of the steel straps,  
 $s$  is the spacing of the steel straps ( $b/s = 1$ , in case of continuous steel plates),  
 $\theta$  is the strut inclination angle,  
 $\beta$  is the angle between the axis of the steel straps and the axis of the member ( $\beta = 90^\circ$ , in case of continuous steel plates), and  $\boxed{\text{AC1}}$   
 $f_{y,j,d}$  is the design yield strength of the steel of the jacket, equal to its nominal strength divided by the partial factor for structural steel in accordance with EN1998-1: 2004, **6.1.3(1)P**.

#### A.4.3.3 Clamping of lap-splices

(1) Steel jackets can provide effective clamping in the regions of lap-splices, to improve cyclic deformation capacity. For this result to be obtained the following is necessary:

- the length of the jacket exceeds by no less than 50% the length of the splice region,
- the jacket is pressured against the faces of the column by at least two rows of bolts on each side normal to the direction of loading,
- when splicing occurs at the base of the column, the rows of bolts should be located one at the top of the splice region and another at 1/3 of that region, starting from the base.

#### A.4.4 FRP plating and wrapping

##### A.4.4.1 Introduction

(1) The main uses of externally bonded FRP (fibre-reinforced polymers) in seismic retrofitting of existing reinforced concrete elements are as follows:

- Enhancement of the shear capacity of columns and walls, by applying externally bonded FRP with the fibers in the hoop direction,
- Enhancement of the available ductility at member ends, through added confinement in the form of FRP jackets, with the fibres oriented along the perimeter,
- Prevention of lap splice failure, through increased lap confinement again with the fibers along the perimeter.

(2) The effect of FRP plating and wrapping of members on the flexural resistance of the end section and on the value of the chord rotation at yielding,  $\theta_y$ , may be neglected

( $\theta_y$  may be computed in accordance with A.3.2.4(2) to (4), with  $l_{oy,min}$  taken equal to  $0,2d_b \cdot f_{yL} / \sqrt{f_c}$ , in A.3.2.4(4)).

#### A.4.4.2 Shear strength

(1) Shear capacity of brittle components can be enhanced in beams, columns or shear walls through the application of FRP strips or sheets. These may be applied either by fully wrapping the element, or by bonding them to the sides and the soffit of the beam (U-shaped strip or sheet), or by bonding them to the sides only.

(2) The total shear capacity, as controlled by the stirrups and the FRP, is evaluated as the sum of one contribution from the existing concrete member, evaluated in accordance with EN 1998-1: 2004 and another contribution,  $V_f$ , from the FRP.

(3) The total shear capacity may not be taken greater than the maximum shear resistance of the concrete member,  $V_{R,max}$ , as controlled by diagonal compression in the web. The value of  $V_{R,max}$  may be calculated in accordance with EN 1992-1-1: 2004. For concrete walls and for columns with shear span ratio,  $L_v/h$ , less or equal to 2, the value of  $V_{R,max}$  is the minimum of the value in accordance with EN 1992-1-1: 2004 and of the value calculated from A.3.3.1(2) and A.3.3.1(3), respectively, under inelastic cyclic loading.

(4) For members with rectangular section, the FRP contribution to shear capacity may be evaluated as:

- for full wrapping with FRP, or for U-shaped FRP strips or sheets,

$$V_{Rd,f} = 0,9 d \cdot f_{idd,e} \cdot 2 \cdot t_f \cdot \left( \frac{w_f}{s_f} \right)^2 \cdot (\cot \theta + \cot \beta) \cdot \sin \beta \quad (A.22)$$

- for side bonded FRP strips or sheets as:

$$V_{Rd,f} = 0,9 d \cdot f_{idd,e} \cdot 2 \cdot t_f \cdot \frac{\sin \beta}{\sin \theta} \cdot \frac{w_f}{s_f} \quad (A.23)$$

where:

$d$  is the effective depth,

$\theta$  is the strut inclination angle,

$f_{idd,e}$  is the design FRP effective debonding strength, which depends on the strengthening configuration in accordance with (5) for fully wrapped FRP, or (6) for U-shaped FRP, or (7) for side bonded FRP,

$t_f$  is the thickness of the FRP strip, sheet or fabric (on single side),

$\beta$  is the angle between the (strong) fibre direction in the FRP strip, sheet or fabric and the axis of the member,

$w_f$  is the width of the FRP strip or sheet, measured orthogonally to the (strong) direction of the fibres (for sheets:  $w_f = \min(0,9d, h_w) \cdot \sin(\theta + \beta) / \sin \theta$ ) and

$s_f$  is the spacing of FRP strips (=  $w_f$  for sheets), measured orthogonally to the

(strong) fibre direction.

(5) For fully wrapped (i.e., closed) or properly anchored (in the compression zone) jackets, the design FRP effective debonding strength may be taken in expressions (A.22), (A.23) as:

$$f_{\text{fdd,e,W}} = f_{\text{fdd}} \cdot \left[ 1 - k \frac{L_e \sin \beta}{2z} \right] + \frac{1}{2} (f_{\text{fu,W}}(R) - f_{\text{fdd}}) \cdot \left[ 1 - \frac{L_e \sin \beta}{z} \right] \quad (\text{A.24})$$

where:

$z = 0,9d$  is the internal lever arm,

$k = \left( 1 - \frac{2}{\pi} \right)$ , and:

$$f_{\text{fdd}} = \frac{1}{\gamma_{\text{fd}}} \sqrt{0,6 \frac{E_f f_{\text{ctm}} k_b}{t_f}} \quad (\text{units: N, mm}) \quad (\text{A.25})$$

is the design debonding strength, with:

$\gamma_{\text{fd}}$  the partial factor for FRP debonding,

NOTE The value ascribed to  $\gamma_{\text{fd}}$  for use in a country can be found in its National Annex. The recommended value is  $\gamma_{\text{fd}}=1,5$ .

$E_f$  the FRP sheets/plates modulus,

$f_{\text{ctm}}$  the concrete mean tensile strength,

$k_b = \sqrt{1,5 \cdot (2 - w_f/s_f) / (1 + w_f/100 \text{ mm})}$  the covering coefficient,

in which:

$w_f, s_f, t_f$  are as defined in (4) and

$f_{\text{fu,W}}(R)$  is the ultimate strength of the FRP strip or sheet wrapped around the corner with a radius  $R$ , given by:

$$f_{\text{fu,W}}(R) = f_{\text{fdd}} + \langle \eta_R \cdot f_{\text{fu}} - f_{\text{fdd}} \rangle \quad (\text{A.26})$$

where the term in  $\langle \cdot \rangle$  should be taken only if positive and where the coefficient  $\eta_R$  depends on the rounding radius  $R$  and the beam width  $b_w$  as:

$$\eta_R = 0,2 + 1,6 \frac{R}{b_w} \quad 0 \leq \frac{R}{b_w} \leq 0,5 \quad (\text{A.27})$$

$L_e$  is the effective bond length:

$$L_e = \sqrt{\frac{E_f \cdot t_f}{\sqrt{4} \cdot \tau_{\text{max}}}} \quad (\text{units: N, mm}) \quad (\text{A.28})$$

with:

$\tau_{\text{max}} = 1,8 f_{\text{ctm}} k_b = \text{maximum bond strength.}$

(6) For U-shaped (i.e., open) jackets, the design FRP effective debonding strength may be taken in expressions (A.22) and (A.23) as:

$$f_{\text{fdd,e,U}} = f_{\text{fdd}} \cdot \left[ 1 - k \frac{L_e \sin \beta}{z} \right] \quad (\text{A.29})$$

where all variables are as defined in (5).

(7) For side-bonded sheets/strips, the design FRP effective debonding strength may be taken in expressions (A.22), (A.23) as:

$$f_{\text{fdd,e,S}} = f_{\text{fdd}} \cdot \frac{z_{\text{rid,eq}}}{z} \cdot \left( 1 - \sqrt{k \frac{L_{\text{eq}}}{z_{\text{rid,eq}}}} \right)^2 \quad (\text{A.30})$$

where:

$$z_{\text{rid,eq}} = z_{\text{rid}} + L_{\text{eq}}, \quad z_{\text{rid}} = z - L_e \cdot \sin \beta, \quad L_{\text{eq}} = \frac{u_1}{\varepsilon_{\text{fdd}}} \cdot \sin \beta \quad (\text{A.31})$$

with:

$$\varepsilon_{\text{fdd}} = f_{\text{idd}}/E_f, \text{ and}$$

$$u_1 = k_b/3.$$

(8) For members with circular section having diameter  $D$ , the FRP contribution is evaluated as:

$$V_f = 0,5 A_c \cdot \rho_f \cdot E_f \cdot \varepsilon_{\text{f,ed}} \quad (\text{A.32})$$

where:

$A_c$  is the column cross-section area,

$\rho_f$  is equal to  $4 t_f/D$  is the volumetric ratio of the FRP, and

$$\varepsilon_{\text{f,ed}} = 0,004.$$

(9) In members with their plastic hinge region fully wrapped in an FRP jacket over a length at least equal to the member depth  $h$ , the cyclic shear resistance,  $V_R$ , may be taken to decrease with the plastic part of the chord rotation ductility demand at the member end:  $\mu_{\Delta}^{\text{pl}} = \mu_{\Delta} - 1$ , in accordance with expression (A.12), adding to  $V_w$  (i.e. to the contribution of transverse reinforcement to shear resistance) that of the FRP jacket. The contribution of the FRP jacket to  $V_w$  may be computed assuming that the FRP stress reaches the design value of the FRP ultimate strength,  $f_{\text{u,fd}}$ , at the extreme tension fibres and reduces linearly to zero over the effective depth  $d$ :

$$V_{\text{w,f}} = 0,5 \rho_f b_w z f_{\text{u,fd}} \quad (\text{A.33})$$

where:

$\rho_f$  equal to  $2t_f/b_w$  is the geometric ratio of the FRP,

$z$  is the length of the internal lever arm, taken equal to  $d$ , and

$f_{\text{u,fd}}$  is the design value of the FRP ultimate strength, equal to the FRP ultimate

strength,  $f_{u,f}$  divided by the partial factor  $\gamma_{fd}$  of the FRP,

NOTE The value ascribed to  $\gamma_{fd}$  for use in a country can be found in its National Annex. The recommended value is  $\gamma_{fd}=1,5$ .

#### A.4.4.3 Confinement action

(1) The enhancement of deformation capacity is achieved through concrete confinement by means of FRP jackets. These are applied around the element to be strengthened in the potential plastic hinge region.

(2) The necessary amount of confinement pressure to be applied depends on the ratio  $I_{\chi} = \mu_{\phi,tar}/\mu_{\phi,ava}$ , between the target curvature ductility  $\mu_{\phi,tar}$  and the available curvature ductility  $\mu_{\phi,ava}$ , and may be evaluated as:

$$f_l = 0,4 I_{\chi}^2 \frac{f_c \cdot \varepsilon_{cu}^2}{\varepsilon_{ju}^{1,5}} \quad (A.34)$$

where:

$f_c$  is the concrete strength, defined as for expression (A.1),

$\varepsilon_{cu}$  is the concrete ultimate strain, and

$\varepsilon_{ju}$  is the adopted FRP jacket ultimate strain, which is lower than the ultimate strain of FRP,  $\varepsilon_{fu}$ .

(3) For the case of circular cross-sections wrapped with continuous sheets (not in strips), the confinement pressure applied by the FRP sheet is equal to  $f_l = 1/2 \rho_f E_f \varepsilon_{ju}$ , with  $E_f$  being the FRP elastic modulus and  $\rho_f$  the geometric ratio of the FRP jacket related to its thickness as:  $t_f = \rho_f D/4$ , where  $D$  is the diameter of the jacket around the circular cross-section.

(4) For the case of rectangular cross-sections in which the corners have been AC1 rounded to a radius  $R$  to allow wrapping the FRP around them (see Figure A.1), the confinement pressure applied by the FRP sheet is evaluated as:  $f_l = k_s f_l$ , with  $k_s = 2R/D$  and  $f_l = 2 \frac{\text{AC1}}{E_f \varepsilon_{ju} t_f / D}$ , where  $D$  is the larger section width.

(5) For the case of wrapping applied through strips with spacing  $s_f$ , the confinement pressure applied by the FRP sheet is evaluated as:  $f_l = k_g f_l$ , with  $k_g = (1 - s_f / 2D)^2$ .

(6) For members of rectangular section with corners rounded as in Figure A.1, an alternative to (2) and (4) is to calculate the total chord rotation capacity or its plastic part through expressions (A.1) or (A.3), respectively, with the exponent of the term due to confinement (i.e. the power of 25 before the last term in expressions (A.1) and (A.3)) increased by  $\alpha \rho_f f_{l,c}$ , with:

(a)  $\rho_f = 2t_f / b_w$ , the FRP ratio parallel to the loading direction,

(b)  $f_{l,c}$ , an effective stress given by the following expression:

$$f_{f,e} = \min(f_{u,f}, \varepsilon_{u,f} E_f) \left( 1 - 0,7 \min(f_{u,f}, \varepsilon_{u,f} E_f) \frac{\rho_f}{f_c} \right) \quad (\text{A.35})$$

where  $f_{u,f}$  and  $E_f$  are the strength and Elastic modulus of the FRP and  $\varepsilon_{u,f}$  a limit strain, equal to 0,015 for CFRP (carbon-fibre-reinforced polymer) or AFRP (aramid-fibre-reinforced polymer) and to 0,02 for GFRP (Glass-fibre-reinforced polymer); and

(c)  $\alpha$ , the confinement effectiveness factor given by:

$$\alpha = 1 - \frac{(b - 2R)^2 + (h - 2R)^2}{3bh} \quad (\text{A.36})$$

where  $R$  is the radius of the rounded corner of the section and  $b$ ,  $h$  the full cross-sectional dimensions (see Figure A.1).

(7) Paragraph (6) applies to members with continuous deformed (high bond) or smooth (plain) longitudinal bars, with or without detailing for earthquake resistance, provided that the end region is wrapped with FRP up to a distance from the end section which is enough to ensure that the yield moment  $M_y$  in the unwrapped part will not be exceeded before the flexural overstrength  $\gamma_{Rd} M_y$  is reached at the end section. To account for the increase of the flexural strength of the end section due to confinement by the FRP,  $\gamma_{Rd}$  should be at least equal to 1,3.

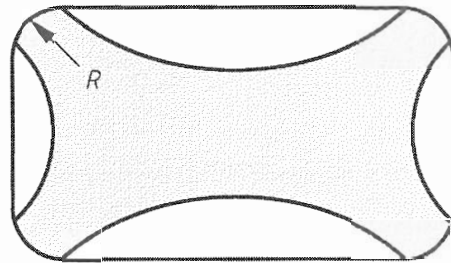

Figure A.1. Effectively confined area in an FRP-wrapped section.

#### A.4.4.4 Clamping of lap-splices

(1) Slippage of lap-splices can be prevented by applying a lateral pressure  $\sigma_l$  through FRP jackets. For circular columns, having diameter  $D$ , the necessary thickness may be estimated as:

$$t_f = \frac{D(\sigma_l - \sigma_{sw})}{2E_f \cdot 0,001} \quad (\text{A.37})$$

where  $\sigma_{sw}$  is the clamping stress due to the stirrups at a strain of 0,001 ( $\sigma_{sw} = 0,001 \rho_w E_s$ ), or the active pressure from the grouting between the FRP and the column, if provided, while  $\sigma_l$  represents the clamping stress over the lap-splice length  $L_s$ , as given by:

$$\sigma_l = \frac{A_s f_{yL}}{\left[ \frac{p}{2n} + 2(d_{bl} + c) \right] L_s} \quad (\text{A.38})$$

where:

- $A_s$  is the area of each spliced longitudinal bar,
- $f_{yL}$  is the yield strength of longitudinal steel reinforcement, taken equal to the mean value obtained from *in-situ* tests and from the additional sources of information, appropriately multiplied by the confidence factor, CF, given in Table 3.1 for the appropriate knowledge level (see **2.2.1(5)P**),
- $p$  is the perimeter line in the column cross-section along the inside of longitudinal steel,
- $n$  is the number of spliced bars along  $p$ ,
- $d_{bL}$  is the (largest) diameter of longitudinal steel bars, and
- $c$  is the concrete cover thickness.

(2) For rectangular columns, the expressions above may be used by replacing  $D$  by  $b_w$ , the section width, and by reducing the effectiveness of FRP jacketing by means of the coefficient in **A.4.4.3(4)**.

(3) For members of rectangular section with longitudinal bars lapped over a length  $l_o$  starting from the end section of the member, an alternative to **(1)** and **(2)** for the calculation of the effect of FRP wrapping over a length exceeding by no less than 25% the length of the lapping, is to apply **A.3.2.2(4)**:

a) taking into account in expression (A.3) confinement only due to transverse bars (exponent of the power of 25 before the last term), and

b) calculating  $l_{ou,min}$  as:  $l_{ou,min} = d_{bL} f_{yL} / [(1,05 + 14,5 \alpha_{i,f} \rho_{f,c} / f_c) \sqrt{f_c}]$  on the basis of the **AC1** FRP alone, with  $\alpha_{i,f} = \alpha(4/n_{tot})$  and  $\rho_f, f_{f,c}, \alpha, n_{tot}$  as defined in **A.4.4.3(6)** for the FRP. **AC1**



## ANNEX B (Informative)

### STEEL AND COMPOSITE STRUCTURES

#### B.1 Scope

This section contains information for the assessment of steel and composite framed buildings in their present state and for their retrofitting, when necessary.

Seismic retrofitting may be either local or global.

#### B.2 Identification of geometry, details and materials

##### B.2.1 General

- (1) The following aspects should be carefully examined:
  - i. Current physical conditions of base metal and connector materials including the presence of distortions.
  - ii. Current physical condition of primary and secondary seismic elements including the presence of any degradation.

##### B.2.2 Geometry

- (1) The collected data should include the following items:
  - i. Identification of the lateral-force resisting systems.
  - ii. Identification of horizontal diaphragms.
  - iii. Original cross-sectional shape and physical dimensions.
  - iv. Existing cross-sectional area, section moduli, moment of inertia, and torsional properties at critical sections.

##### B.2.3 Details

- (1) The collected data should include the following items:
  - (i) Size and thickness of additional connected materials, including cover plates, bracing and stiffeners.
  - (ii) Amount of longitudinal and transverse reinforcement steel and of dowels in composite beams, columns and walls.
  - (iii) Amount and proper detailing of confining steel in critical regions.

(iv) As built configuration and properties of intermediate, splice and end connections.

#### **B.2.4 Materials**

- (1) The collected data should include the following items:
  - i. Concrete strength.
  - ii. Steel yield strength, strain hardening, ultimate strength and elongation.
- (2) Areas of reduced stress, such as flange tips at beam-column ends and external plate edges, should be selected for inspection as far as possible.
- (3) To evaluate material properties, samples should be removed from web plates of hot rolled profiles for components designed as dissipative.
- (4) Flange plate specimens should be used to characterise the material properties of non dissipative members and/or joints.
- (5) Gamma radiography, ultrasonic testing through the architectural fabric or boroscopic review through drilled access holes are viable testing methods when accessibility is limited or for composite components.
- (6) Soundness of base and filler materials should be proved on the basis of chemical and metallurgical data.
- (7) Charpy V-Notch toughness tests should be used to prove that heat affected zones, if any, and surrounding material have adequate resistance for brittle fracture.
- (8) Destructive and/or non destructive tests (liquid penetrant, magnetic particle, acoustic emission) and ultrasonic or tomographic methods may be used.

### **B.3 Requirements on geometry and materials of new or modified parts**

#### **B.3.1 Geometry**

- (1) Steel sections of new elements should satisfy width-to-thickness slenderness limitations based on class section classification as in EN 1998-1: 2004, Sections 6 and 7.
- (2) The transverse links enhance the rotation capacities of existing or new beam-columns even with slender flanges and webs. Such transverse bars should be welded between the flanges in compliance with EN 1998-1: 2004, 7.6.5.
- (3) The transverse links of (2) should be spaced as transverse stirrups used for encased members.

#### **B.3.2 Materials**

##### **B.3.2.1 Structural steel**

- (1) Steel satisfying EN 1998-1: 2004, 6.2 should be used for new parts or for

replacement of existing structural components.

(2) When the strength and stiffness of the structural components are evaluated at each LS, the effects of composite action should be taken into account.

(3) The through-thickness resistance in column flanges should be based upon the reduced strength as follows:

$$f_u = 0,90 \cdot f_y \quad (\text{B.1})$$

(4) Element thickness should comply with the requirements of EN 1993-1-10: 2004, Table 2.1, depending on the Charpy V-Notch (CVN) energy and other relevant parameters.

(5) Welding consumables should meet the requirements of EN 1993-1-8: 2004, **4.2**.

(6) In wide flange sections coupons should be cut from intersection zones between flange and web. This is an area (*k-area*) of potentially reduced notch toughness because of the slow cooling process during fabrication.

### **B.3.2.2 Reinforcing steel**

(1) New reinforcing steel in both dissipative and non dissipative zones of new or modified elements should be of class C in EN 1992-1-1: 2004.

### **B.3.2.3 Concrete**

(1) New concrete of new or modified components should conform with EN 1998-1: 2004, **7.2.1(1)**.

## **B.4 System retrofitting**

### **B.4.1 General**

(1) Global retrofitting strategies should be able to increase the capacity of lateral-force resisting systems and horizontal diaphragms and/or decrease the demand imposed by seismic actions.

(2) The retrofitted structural system should satisfy the following requirements:

- i. Regularity of mass, stiffness and strength distribution, to avoid detrimental torsional effects and/or soft-storey mechanisms.
- ii. Masses and stiffness sufficient to avoid highly flexible structures, which may give rise to extensive non-structural damage and significant P- $\Delta$  effects.
- iii. Continuity and redundancy between members, so as to ensure a clear and uniform load path and prevent brittle failures.

(3) Global interventions should include one or more of the following strategies:

- i. Stiffening and strengthening of the structure and its foundation system.
  - ii. Enhancement of ductility of the structure.
  - iii. Mass reduction.
  - iv. Seismic isolation.
  - v. Supplemental damping.
- (4) For all structural systems, stiffening, strengthening and enhancement of ductility may be achieved by using the strategies provided in Sections **B.5** and **B.6**.
- (5) Mass reduction may be achieved through one of the following measures:
- i. Replacement of heavy cladding systems with lighter systems.
  - ii. Removal of unused equipment and storage loads.
  - iii. Replacement of masonry partition walls with lighter systems.
  - iv. Removal of one or more storeys.
- (6) Base isolation should not be used for structures with fundamental periods greater than 1,0 s. Such periods should be computed through eigenvalue analysis.
- (7) Base isolation should be designed in compliance with EN 1998-1: 2004 for new buildings.
- (8) Re-assessment of the foundation system (after the retrofitting) should be performed in accordance with EN 1998-1: 2004, **4.4.2.6**. If linear analysis is used, the values of  $\Omega$  in **4.4.2.6(4)** will normally be less than 1,0.

#### **B.4.2 Moment resisting frames**

- (1) The enhancement of the composite action between steel beams and concrete slabs through shear studs, encasement of beams and columns in RC should be used to increase the global stiffness at all limit states.
- (2) The length of the dissipative zones should be consistent with the hinge location given at the first row of Table B.6.
- (3) Moment resisting frames may be retrofitted through semi-rigid and/or partial strength joints, either steel or composite.
- (4) The fundamental period of frames with semi-rigid connections may be computed as follows:

$$T = 0,085 \cdot H^{(0,85 - m/180)} \text{ if } 5 < m < 18 \text{ (semi-rigid)} \quad (\text{B.2})$$

$$T = 0,085 \cdot H^{3/4} \text{ if } m \geq 18 \text{ (rigid)} \quad (\text{B.3})$$

where  $H$  is the frame height in metres and the parameter  $m$  is defined as follows:

$$m = \frac{(K_{\varphi})_{\text{con}}}{(EI/L)_b} \quad (\text{B.4})$$

where:

- $K_{\varphi}$  is the connection rotation stiffness,
- $I$  is the moment of inertia of the beam,
- $L$  is the beam span,
- $E$  is Young's modulus of the beam.

(5) In addition to the pattern of horizontal forces given in EN 1998-1: 2004, 4.3.3.2.3 and in 4.4.4.2(1) of this standard, the following pattern of forces ( $F_{x,i}$ ) should be used in the (linear) lateral force analysis and in the nonlinear static (pushover) analysis to detect the onset of all limit states:

$$F_{x,i} = \frac{W_{x,i} \cdot h_{x,i}^{\delta}}{\sum W_{x,i} \cdot h_{x,i}^{\delta}} \cdot F_b \quad (\text{B.5})$$

where  $F_b$  is the seismic base shear and  $\delta$  is given by:

$$\delta = \begin{cases} 1,0 & \text{if } T \leq 0,50 \text{ s} \\ 0,50 \cdot T + 0,75 & \text{if } 0,50 < T < 2,50 \text{ s} \\ 2,0 & \text{if } T > 2,50 \text{ s} \end{cases} \quad (\text{B.6})$$

### B.4.3 Braced frames

- (1) Frames with eccentric bracing and knee-braced frames should be preferred for the retrofitting to frames with concentric bracing.
- (2) Knee-braced frames are systems in which the bracing are connected to a dissipative zone, instead of the beam-to-column connection.
- (3) Aluminium or stainless steel may be used for dissipative zones in concentric, eccentric or knee-braced frames, only if their use is validated by testing.
- (4) Steel, concrete and/or composite walls may be used in the retrofitting to enhance ductile response and prevent beam-column instability. Their design and that of their connection with steel members should comply with EN 1998-1: 2004.
- (5) Steel panels may employ low-yield steel and should be shop-welded and field bolted.
- (6) Bracing may be introduced in moment resisting frames to increase their lateral stiffness.

## B.5 Member assessment and retrofitting

### B.5.1 General requirements

- (1) Beams  $\overline{AC1}$  should develop their full plastic moments  $\overline{AC1}$  without local buckling in the flange or in the web at the SD LS. Local buckling should be limited at the NC LS.
- (2) At the LS of DL and of SD, axial and flexural yielding or buckling should not occur in columns.
- (3) Diagonal braces should sustain plastic deformations and dissipate energy through successive cycles of yielding and buckling. At the LS of DL buckling should be avoided.
- (4) Steel plates should be welded to flanges and/or webs to reduce the slenderness ratios.
- (5) The moment capacity  $M_{pb,Rd}$  of the beam at the location of the plastic hinge should be computed as:

$$M_{pb,Rd,b} = Z_e \cdot f_{yb} \quad (B.7)$$

where:

$Z_e$  is the effective plastic modulus of the section at the plastic hinge location, computed with reference to the actual measured size of the section, and

$f_{yb}$  is the yield strength of the steel in the beam; for existing steel,  $f_{yb}$  may be taken equal to the mean value obtained from *in-situ* tests and from the additional sources of information, appropriately multiplied by the confidence factor, CF, given in Table 3.1 for the appropriate knowledge level (see 3.5(2)P); for new steel,  $f_{yb}$  may be taken equal to the nominal value multiplied by the overstrength factor  $\gamma_{ov}$  for the steel of the beam, determined in accordance with EN 1998-1:2004: 6.2(3), (4) and (5).

- (6) The moment demand  $M_{cf,Ed}$  in the critical section at the column face is evaluated as follows:

$$M_{cf,Ed} = M_{pl,Rd,b} + V_{pl,Rd,b} \cdot e \quad (B.8)$$

where

$M_{pl,Rd,b}$  is the beam plastic moment at the beam plastic hinge,

$V_{pl,Rd,b}$  is the shear at the beam plastic hinge,

$e$  is the distance between the beam plastic hinge and the column face.

- (7) The moment demand  $M_{cc,Ed}$  in the critical section at column centreline may be calculated as follows:

$$M_{cc,Ed} = M_{pl,Rd,b} + V_{pl,Rd,b} \cdot \left( e + \frac{d_c}{2} \right) \quad (B.9)$$

where  $d_c$  is the column depth.

### B.5.2 Member deformation capacities

- (1) The inelastic deformation capacities of structural members at the three LSs may be taken as given in the following paragraphs.
- (2) The inelastic deformation capacities of beam-to-column joints may be taken equal to those given in a Table B.6 (clause B.6.2.1), provided that connected members fulfil the requirements given in the first five rows of Table B.6.
- (3) For beams and columns in flexure, the inelastic deformation capacity should be expressed in terms of the plastic rotation at the end of the member, as a multiple of the chord rotation at yielding,  $\theta_y$ , at the end in question. For beams and columns with dimensionless axial load  $\nu$  not greater than 0,30, the inelastic deformation capacities at the three LSs may be taken in accordance with Table B.1

**Table B.1: Plastic rotation capacity at the end of beams or columns with dimensionless axial load  $\nu$  not greater than 0,30.**

Class of cross section	Limit State		
	DL	SD	NC
1	1,0 $\theta_y$	6,0 $\theta_y$	8,0 $\theta_y$
2	0,25 $\theta_y$	2,0 $\theta_y$	3,0 $\theta_y$

- (4) For braces in compression the inelastic deformation capacity should be expressed in terms of the axial deformation of the brace, as a multiple of the axial deformation of the brace at buckling load,  $\Delta_c$ . For braces in compression (except for braces of eccentric braced frames) the inelastic deformation capacities at the three LSs may be taken in accordance with Table B.2:

**Table B.2: Axial deformation capacity of braces in compression (except braces of eccentric braced frames).**

Class of cross section	Limit State		
	DL	SD	NC
1	0,25 $\Delta_c$	4,0 $\Delta_c$	6,0 $\Delta_c$
2	0,25 $\Delta_c$	1,0 $\Delta_c$	2,0 $\Delta_c$

- (5) For braces in tension the inelastic deformation capacity should be expressed in terms of the axial deformation of the brace, as a multiple of the axial deformation of the brace at tensile yielding load,  $\Delta_t$ . For braces in tension (except for braces of eccentric braced frames) with cross section class 1 or 2, the inelastic deformation capacities at the three LSs may be taken in accordance with Table B.3:

**Table B.3: Axial deformation capacity of braces in tension (except braces of eccentric braced frames).**

Limit State		
DL	SD	NC
0,25 $\Delta_t$	7,0 $\Delta_t$	9,0 $\Delta_t$

(6) For beams or columns in tension the inelastic deformation capacity should be expressed in terms of the axial deformation of the member, as a multiple of its axial deformation at tensile yielding load,  $\Delta_t$ . For beams or columns in tension (except for those in eccentric braced frames) with cross section class 1 or 2, the inelastic deformation capacities at the three LSs may be taken in accordance with Table B.4.

**Table B.4: Axial deformation capacity of beams or columns in tension (except beams or columns of eccentric braced frames).**

Limit State		
DL	SD	NC
0,25 $\Delta_t$	3,0 $\Delta_t$	5,0 $\Delta_t$

### B.5.3 Beams

#### B.5.3.1 Stability deficiencies

(1) Beams with span-to-depth ratios between 15 and 18 should be preferred to enhance energy absorption. Therefore, intermediate supports should be used in the retrofitting to shorten long spans.

(2) Lateral restraint should be provided to flanges with a stability deficiency. Lateral restraint of the top flange is not required, if the composite action with the slab is reliable. Otherwise, the composite action should be enhanced by fulfilling the requirements in **B.5.3.5**.

#### B.5.3.2 Resistance deficiencies

(1) Steel plates should be added to flanges of beams to increase deficient flexural capacity. Addition of steel to the top flange is not required, if the composite action with the slab is reliable. Alternatively, structural steel beams with deficient flexural capacity should be encased in RC.

(2) Longitudinal reinforcing bars that may be added to increase a deficient flexural capacity should be of class C in accordance with EN 1992-1-1: 2004, Table C.1.

(3) Beams retrofitted due to resistance deficiencies, should fulfil the requirements of EN 1998-1: 2004 for ductility class M.

(4) Steel plates should be added to the beam web for H-section, or to the wall for hollow sections, to enhance a deficient shear capacity.



### B.5.3.3 Repair of buckled and fractured flanges

- (1) Buckled and/or fractured flanges should be either strengthened or replaced with new plates.
- (2) Buckled bottom and/or top flanges should be repaired by adding full height web stiffeners on both sides of the beam webs in accordance with (3) as follows, and by heat straightening of the buckled flange, or its removal and replacement with a similar plate in accordance with (4) and (5) as follows.
- (3) Web stiffeners should be located at the edge and centre of the buckled flange, respectively; the stiffener thickness should be equal to the beam web.
- (4) New plates should be either welded in the same location as the original flange, (i.e., directly to the beam web), or welded onto the existing flange. In both cases the added plates should be oriented with the rolling direction in the longitudinal direction.
- (5) Special shoring of the flange plates should be provided during cutting and replacement.
- (6) Instead of welding a thick plate onto the flange, the steel beam should be preferably encased in RC.

### B.5.3.4 Weakening of beams

- (1) The ductility of steel beams may be improved by weakening of the beam flange at desired locations, to shift the dissipative zones away from the connections.
- (2) Reduced beam sections (RBSs) behave like a fuse that protects beam-to-column connections against early fracture. The reduced beam sections should be such that they can develop at each LS the minimum rotations specified in Table B.5.

**Table B.5. - Required rotation capacity of reduced beam sections, RBSs (in radians).**

DL	SD	NC
0,010	0,025	0,040

- (3) The rotations in Table B.5 may be considered to be achieved, if the design of RBS in the beam is carried out through the procedure outlined hereafter:

- i. Compute the distance of the beginning of the RBS from the column face,  $a$ , and the length over which the flange will be reduced,  $b$ , as follows:

$$a = 0,60b_f \quad (\text{B.10})$$

$$b = 0,75d_b \quad (\text{B.11})$$

where:

$b_f$  is the flange width.

$d_b$  is the beam depth.

- ii. Compute the distance of the intended plastic hinge section at the centre of the RBS,  $s$ , from the column face as:

$$s = a + \frac{b}{2} \quad (\text{B.12})$$

AC1

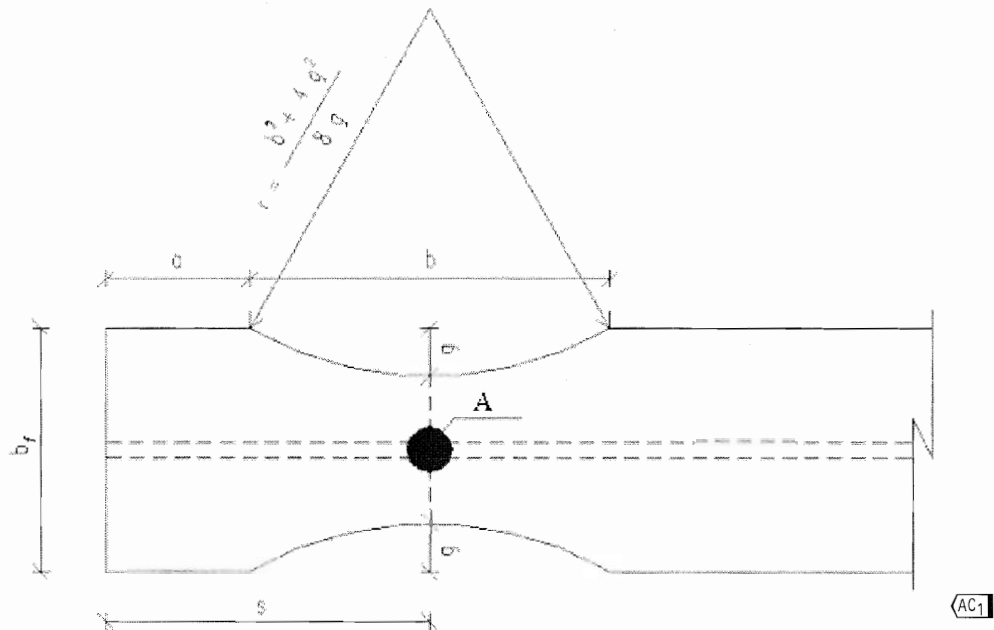

**Key:**

A = Plastic hinge

**Figure B.1. - Geometry of flange reduction for reduced beam section (RBS).**

- iii. Determine the depth of the flange cut ( $g$ ) on each side; this depth should be not greater than  $0,25 \cdot b_f$ . As a first trial it may be taken as:

$$g = 0,20b_f \quad (\text{B.13})$$

- iv. Compute the plastic modulus ( $Z_{\text{RBS}}$ ) and the plastic moment ( $M_{\text{pl,Rd,RBS}}$ ) of the plastic hinge section at the centre of the RBS:

$$Z_{\text{RBS}} = Z_b - 2 \cdot g \cdot t_f \cdot (d_b - t_f) \quad (\text{B.14})$$

$$M_{\text{pl,Rd,RBS}} = Z_{\text{RBS}} \cdot f_{yb} \quad (\text{B.15})$$

where  $Z_b$  is the plastic modulus of the beam and  $f_{yb}$  is as defined in **B.5.1(5)**.

- v. Compute the shear force ( $V_{\text{pl,RBS}}$ ) in the section of plastic hinge formation from equilibrium of the beam part ( $L'$ ) between the two intended plastic hinges (Figure B.2). For a uniform gravity load  $w$  acting on the beam in the seismic design situation:

$$V_{\text{pl,RBS}} = \frac{2M_{\text{pl,Rd,RBS}}}{L'} + \frac{wL'}{2} \quad (\text{B.16})$$

Different distributions of the gravity loads along the beam span should be properly accounted for in (the last term of) Expression (B.16).

- vi. Compute the beam plastic moment away from the RBS,  $M_{pl,Rd,b}$ , as follows:

$$M_{pl,Rd,b} = Z_b \cdot f_{yb} \quad (B.17)$$

where  $Z_b$  and  $f_{yb}$  are as defined in step (iv) above.

- vii. Verify that  $M_{pl,Rd,b}$  is greater than the bending moment that develops at the column face when a plastic hinge forms at the centre of the RBS:  $M_{cf,Ed} = M_{pb,Rd,RBS} + V_{pl,RBS} \cdot e$ . If it is not, increase the cut-depth  $g$  and repeat steps (iv) to (vi). The length  $b$  should be  $\overline{AC1}$  chosen such that  $M_{cf,Ed}$  is about 85% to 100% of  $M_{pl,Rd,b}$ .

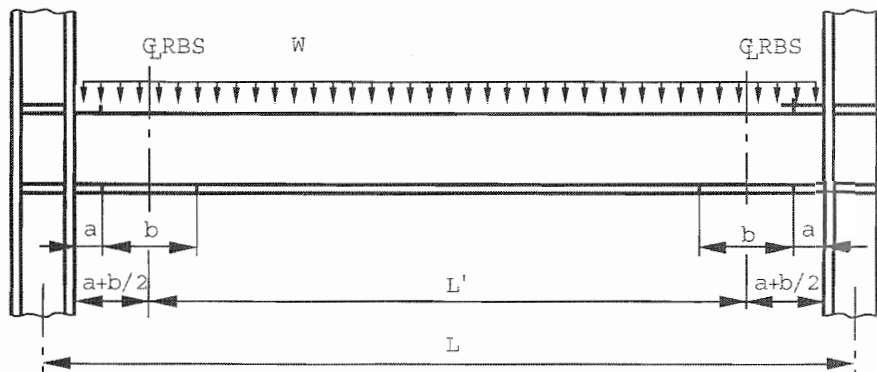

**Key:**

$w$  = uniform gravity load in the seismic design situation

$L'$  = Distance between the centres of RBS cuts

$L$  = Distance between column centerlines

**Figure B.2.** -Typical sub-frame assembly with reduced beam sections (RBS).

- viii. Check the width-to-thickness ratios at the RBS to prevent local buckling. The flange width should be measured at the ends of the central two-thirds of the reduced section of the beam.

- ix. Compute the radius ( $r$ ) of the cuts in both top and bottom flanges over the length  $b$  of the RBS of the beam:

$$r = \frac{b^2 + 4g^2}{8g} \quad (B.18)$$

- x. Check that the fabrication process ensures the adequate surface roughness (i.e. between 10 and 15  $\mu\text{m}$ ) for the finished cuts and that grind marks are not present.

**B.5.3.5 Composite elements**

- (1) The calculation of the capacity of composite beams should take into account the degree of shear connection between the steel member and the slab.

- (2) Shear connectors between steel beams and composite slabs should not be used within dissipative zones. They should be removed from existing composite beams.
- (3) Studs should be attached to flanges through arc-spot welds, but without full penetration of the flange. Shot or screwed attachments should be avoided.
- (4) The maximum tensile strains due to the presence of composite slabs should be checked that they do not provoke flange tearing.
- (5) Encased beams should be provided with stirrups.

## B.5.4 Columns

### B.5.4.1 Stability deficiencies

- (1) The width-to-thickness ratio may be reduced by welding steel plates to the flange and/or the webs.
- (2) The width-to-thickness ratio of hollow sections may be reduced by welding external steel plates.
- (3) Lateral restraint should be provided to both flanges, through stiffeners with strength not less than:

$$0,06f_{yc} \cdot b_f \cdot t_f \quad (\text{B.19})$$

where:

$b_f$  is the flange width,

$t_f$  is the flange thickness, and

$f_{yc}$  is the yield strength of the steel in the column; for existing steel,  $f_{yc}$  may be taken equal to the mean value obtained from *in-situ* tests and from the additional sources of information, multiplied by the confidence factor, CF, given in Table 3.1 for the appropriate knowledge level (see 3.5(2)P); for new steel,  $f_{yc}$  may be taken equal to the nominal value multiplied by the overstrength factor  $\gamma_{ov}$  for the steel of the column, determined in accordance with EN 1998-1: 2004, 6.2(3), (4) and (5).

### B.5.4.2 Resistance deficiencies

- (1) To increase the flexural capacity of the section, steel plates may be welded to the flanges and/or webs for H-sections and to the walls for hollow sections.
- (2) Structural steel columns may be encased in RC, to increase their flexural capacity.
- (3) Retrofitting should ensure that in all primary seismic columns the axial compression in the design seismic situation is not greater than 1/3 of the design value of the plastic resistance to normal forces of the gross cross-section of the column  $N_{pl,Rd} = \overline{AC1} (A_a f_{yd} + A_c f_{cd} + A_s f_{sd})$  (see EN 1998-1:2004, 7.6.4(2)) at the DL LS  $\overline{AC1}$  and 1/2 of  $N_{pl,Rd}$  at the SD or NC LSSs.

#### B.5.4.3 Repair of buckled and fractured flanges and of fractures of splices

- (1) Buckled and/or fractured flanges and fractured splices should be either strengthened or replaced with new plates.
- (2) Buckled and fractured flanges should be repaired either through removal of the buckled plate flange and replacement with a similar plate, or through flame straightening.
- (3) Splice fractures should be repaired by adding external plates on the column flanges via complete penetration groove welds. The damaged part should be removed and replaced with sound material. The thickness of the added plates should be equal to that of the existing ones. The replacement material should be aligned so that the rolling direction matches that of the column.
- (4) Small holes should be drilled at the edge of cracks in columns to prevent propagation.
- (5) Magnetic particle, or liquid dye penetrant tests should be used to ensure that there are no further defects and/or discontinuities up to a distance of 150mm from a cracks.

#### B.5.4.4 Requirements for column splices

- (1) New splices should be located in the middle third of the column clear height. They should be designed to develop a design shear strength not less than the smaller of the expected shear strengths of the two connected members and a design flexural strength not less than 50% of the smaller of the expected flexural strengths of the two connected sections. Thus, welded column splices should satisfy the following expression at each flange:

$$A_{\text{spl}} \cdot f_{\text{yd}} \geq 0,50 \cdot f_{\text{yc}} \cdot A_{\text{fl}} \quad (\text{B.20})$$

where:

- $A_{\text{spl}}$  is the area of each flange of the splice,
- $f_{\text{yd}}$  is the design yield strength of the flange of the splice,
- $A_{\text{fl}}$  is the flange area of the smaller of the two columns connected, and
- $f_{\text{yc}}$  is the yield strength of the column material, defined as in **B.5.4.1(3)**.

#### B.5.4.5 Column panel zone

- (1) In the retrofitted column the panel zone at beam-column connections should remain elastic at the DL LS.
- (2) The thickness,  $t_w$ , of the column panel zone (including the doubler plate, if any, see **(3)**) should satisfy the following expression, to prevent premature local buckling under large inelastic shear deformations:

$$t_w \leq \frac{d_z + w_z}{90} \quad (\text{B.21})$$

where:

$d_z$  is the panel-zone depth between continuity plates,

$w_z$  is the panel-zone width between column flanges.

Plug welds should be used between the web and the added plate.

(3) Steel plates parallel to the web and welded to the tip of flanges (doubler plates) may be used to stiffen and strengthen the column web.

(4) Transverse stiffeners should be welded onto the column web, at the level of the beam flanges.

(5) To ensure satisfactory performance at all limit states, continuity plates with thickness not less than that of beam flanges should be placed symmetrically on both sides of the column web.

#### B.5.4.6 Composite elements

(1) Encasement in RC may be used to enhance the stiffness, strength and ductility of steel columns.

(2) To achieve effective composite action, shear stresses should be transferred between the structural steel and reinforced concrete through shear connectors placed along the column.

(3) To prevent shear bond failure, the ratio of the steel flange width to that of the composite column,  $b_f/B$ , should not be greater than the critical value of this ratio defined as follows:

$$\left(\frac{b_f}{B}\right)_{cr} = 1 - 0,35 \cdot \left[ 0,17 \cdot \left( 1 + 0,073 \cdot \frac{N_{Ed}}{A_g} \right) \cdot \sqrt{f_{cd}} + 0,20 \cdot \rho_w \cdot f_{yw,d} \right] \quad (\text{B.22})$$

where:

$N_{Ed}$  is the axial force in the seismic design situation,

$A_g$  is the gross area of the composite section,

$f_{cd}$  is the design value of compressive strength of the concrete,

$\rho_w$  is the ratio of transverse reinforcement,

$f_{yw,d}$  is the design value of the yield strength of transverse reinforcement,

$B$  is the width of the composite section,

$b_f$  is the steel flange width.

## B.5.5 Bracings

### B.5.5.1 Stability deficiencies

- (1) **B.5.4.1(1)** applies for bracings consisting of hollow sections.
- (2) **B.5.4.2(1)** applies.
- (3) Any encasement of steel bracings for retrofitting should comply with EN 1998-1: 2004.
- (4) Lateral stiffness of diagonal braces may be improved by increasing the stiffness of the end connections.
- (5) X bracings should be preferred for the retrofitting over V or inverted V bracings. K bracings may not be used.
- (6) Closely spaced batten plates are effective in improving the post-buckling response of braces, particularly in double-angle or double-channel ones. If batten plates are already in place in the existing columns, new plates may be welded and/or existing batten connections should be strengthened.

### B.5.5.2 Resistance deficiencies

- (1) At the DL LS the axial compression in the design seismic situation should be not greater than 80% of the design value of the plastic resistance to normal forces of the cross-section of the bracing:  $N_{pl,Rd}$ .
- (2) Unless only the NC LS is verified, the capacity in compression of the braces of concentrically braced frames should be not less than 50% of the plastic resistance to normal forces of the cross-section,  $N_{pl,Rd}$ .

### B.5.5.3 Composite elements

- (1) Encasement of steel bracings in RC increases their stiffness, strength and ductility. For steel braces with H-section, partial or full encasement may be used.
- (2) Fully encased bracings should be provided with stiffeners and stirrups, and partially encased ones with straight links in accordance with EN 1998-1: 2004, **7.6.5**. Stirrups should have uniform spacing along the brace and should comply with the requirements specified for ductility class M in EN 1998-1: 2004, **7.6.4(3)**, **(4)**.
- (3) Only the structural steel section should be taken into account in the calculation of the capacity of composite braces in tension.

### B.5.5.4 Unbonded bracings

- (1) Braces may be stiffened by being incorporated unbonded either in RC walls or in concrete-filled tubes.
- (2) The brace should be coated with debonding material, to reduce bond between

the steel component and the RC panel or the concrete infilling the tube.

(3) Low yield strength steels is appropriate for the steel brace; steel-fibre reinforced concrete may be used as unbonding material.

(4) Braces stiffened by being incorporated unbonded in RC walls should conform with the following:

$$\left(1 - \frac{1}{n_E^B}\right) \cdot m_y^B > 1,30 \cdot \frac{a}{l} \quad (\text{B.23})$$

where:

$a$  is the initial imperfection of the steel brace,

$l$  is the length of the steel brace,

$m_y^B$  is the non-dimensional strength parameter of the RC panel:

$$m_y^B = \frac{M_y^B}{N_{pl,R} \cdot l} \quad (\text{B.24})$$

$n_E^B$  is the non-dimensional stiffness parameter of the RC panel:

$$n_E^B = \frac{N_E^B}{N_{pl,R}} \quad (\text{B.25})$$

where:

$$M_y^B = \frac{5 \cdot B_S \cdot t_c^2 \cdot f_{ct}}{6} \quad (\text{B.26})$$

$$N_E^B = \frac{5 \cdot \pi^2 \cdot B_S \cdot E_c \cdot t_c^3}{12 \cdot l^2} \quad (\text{B.27})$$

where:

$E_c$  is the elastic modulus of concrete,

$B_S$  is the width of the steel brace in the form of a flat bar,

$t_c$  is the thickness of the RC panel,

$f_{ct}$  is the tensile strength of concrete,

$N_{pl,R}$  is the plastic capacity of the steel brace in tension, computed on the basis of the mean value of steel yield stress obtained from *in-situ* tests and from the additional sources of information, divided by the confidence factor, CF, given in Table 3.1 for the appropriate knowledge level.

(6) Edge reinforcement of the RC panel should be adequately anchored to prevent failure by punching shear.

(7) The infilled concrete tubes with debonding material should be adequate to prevent buckling of the steel brace.



## B.6 Connection retrofitting

### B.6.1 General

- (1) Connections of retrofitted members should be checked taking into account the resistance of the retrofitted members, which may be higher than that of the original ones (before retrofitting).
- (2) The retrofitting strategies provided may be applied to steel or composite moment and braced frames.

### B.6.2 Beam-to-column connections

#### B.6.2.1 General

- (1) The retrofitting should aim at shifting the beam plastic hinge away from the column face (see first row in Table B.6).
- (2) Beam-to-column connections may be retrofitted through either weld replacement, or a weakening strategy, or a strengthening strategy.
- (3) To ensure development of plastic hinges in beams, rather than in columns, the column-to-beam moment ratio (*CBMR*) should satisfy the following condition:

$$CBMR = \frac{\sum M_{Rd,c}}{\sum M_{pl,R,b}} \geq 1,30 \quad (B.28)$$

where:

$$(a) \text{ for the steel columns: } \sum M_{Rd,c} = \sum \left[ Z_c \cdot \left( f_{yd,c} - \frac{N_{Ed}}{A_c} \right) \right]_i \quad (B.29)$$

where the summation extends over the column sections around the joint, and:

- $Z_c$  is the plastic modulus of the column section, evaluated on the basis of actual geometrical properties, if available, and taking into account haunches, if any,
- $N_{Ed}$  is the axial load of the column in the seismic design situation,
- $A_c$  is the area of the column section,
- $f_{yd,c}$  is the design yield strength of steel in the column, computed on the basis of the mean value of steel yield stress obtained from *in-situ* tests and from the additional sources of information, divided by the confidence factor, CF, given in Table 3.1 for the appropriate knowledge level.

- (b)  $\sum M_{pl,R,b}$  is the sum of flexural strengths at plastic hinge locations in beams framing into the joint in the horizontal direction considered, taking into account the eccentricity to the column centreline:

$$\sum M_{pl,R,b} = \sum (Z_b \cdot f_{yb} + M_{cc,Ed})_j \quad (\text{B.30})$$

where:

$Z_b$  is the plastic modulus of the beam section at the potential plastic hinge location, computed on the basis of the actual geometry,

$f_{yb}$  is the yield strength of steel in the beam, defined as in **B.5.1(5)**,

$M_{cc,Ed}$  is the additional moment at the column centreline due to the eccentricity of the shear force at the plastic hinge in the beam.

**Table B.6. – Requirements on retrofitted connections and resulting rotation capacities.**

	IWUFCs	WBHCs	WTBHCs	WCPFCs	RBSCs
Hinge location (from column centreline)	$(d_c/2) + (d_b/2)$	$(d_c/2) + l_h$	$(d_c/2) + l_h$	$(d_c/2) + l_{cp}$	$(d_c/2) + (b/2) + a$
Beam depth (mm)	$\leq 1000$	$\leq 1000$	$\leq 1000$	$\leq 1000$	$\leq 1000$
Beam span-to-depth ratio	$\geq 7$	$\geq 7$	$\geq 7$	$\geq 7$	$\geq 7$
Beam flange thickness (mm)	$\leq 25$	$\leq 25$	$\leq 25$	$\leq 25$	$\leq 44$
Column depth (mm)	No restriction	$\leq 570$	$\leq 570$	$\leq 570$	$\leq 570$
Rotation at DL LS (rad)	0,013	0,018	0,018	0,018	0,020
Rotation at SD LS (rad)	0,030	0,038	0,038	0,040	0,030
Rotation at NC LS (rad)	0,050	0,054	0,052	0,060	0,045

Keys:

IWUFCs = Improved welded unreinforced flange connections.

WBHCs = Welded bottom haunch connections.

WTBHCs = Welded top and bottom haunch connections.

WCPFCs = Welded cover plate flange connections.

RBSCs = Reduced beam section connections.

$d_c$  = Column depth.

$d_b$  = Beam depth.

$l_h$  = Haunch length.

$l_{cp}$  = Cover plate length.

$a$  = Distance of the radius cut from the beam edge.

$b$  = Length of the radius-cut.

(4) The requirements for beams and columns in retrofitted connections are given in Table B.6. The same Table gives the rotation capacity at the three LSs that is provided by the connection if the requirements are fulfilled.

### B.6.2.2 Weld replacement

- (1) The existing filler material should be removed and replaced with sound material.
- (2) Backing bars should be removed after welding, because they may cause initiation of cracks.
- (3) Transverse stiffeners at the top and bottom of the panel zone should be used to strengthen and stiffen the column panel (see **B.5.4.5(4)**). Their thickness should be not less than that of beam flanges.
- (4) Transverse and web stiffeners should be welded to column flanges and to the web via complete joint penetration welds.

### B.6.2.3 Weakening strategies

#### B.6.2.3.1 Connections with RBS beams

- (1) Reduced Beam Sections (RBS), designed in accordance with **(5)**, can force plastic hinges to occur within the reduced section, thus decreasing the likelihood of fracture at the beam flange welds and in the surrounding heat affected zones.
- (2) The beam should be connected to the column flange either through welded webs, or through shear tabs welded to the column flange face and to the beam web. The tab length should be equal to the distance between the weld access holes, with an offset of 5 mm. A minimum tab thickness of 10 mm is required. Shear tabs should be either cut square or with tapered edges (tapering corner about 15°) and should be placed on both sides of the beam web.
- (3) Welding should employ groove welds or fillet welds for the column flange and fillet welds for the beam web. Bolting of the shear tab to the beam web is allowed as an alternative.
- (4) Shear studs should not be placed within the RBS zones.
- (5) The design procedure for RBS connections is outlined below:
  - i. Use RBS beams designed in accordance with the procedure in **B.5.3.4**, but computing the beam plastic moment,  $M_{pl,Rd,b}$ , as:

$$M_{pl,Rd,b} = Z_{RBS} \cdot f_{yb} \cdot \left( \frac{L - d_c}{L - d_c - 2 \cdot b} \right) \quad (\text{B.31})$$

where:

- $f_{yb}$  is the yield strength of steel in the beam, defined as in **B.5.1(5)**,
- $L$  is the distance between column centerlines,
- $d_c$  is the column depth, and
- $b$  is the length of RBS.

- ii. Compute the beam shear,  $V_{pl,Rd,b}$ , in accordance with **B.5.3.4(3)v** for a span length between plastic hinges,  $L'$ :

$$L' = L - d_c - 2 \cdot b \quad (\text{B.32})$$

- iii. Verify the web connection, e.g. the welded shear tab, for the shear force  $V_{pl,Rd,b}$  from ii above.
- iv. Check that the column-to-beam flexural capacity ratio,  $CBMR$ , satisfies the condition:

$$CBMR = \frac{\sum Z_c \left( f_{yd,c} - \frac{N_{Ed}}{A_c} \right)}{\sum Z_b \cdot f_{yb} \cdot \left( \frac{L - d_c}{L - d_c - 2 \cdot b} \right)} \geq 1,20 \quad (\text{B.33})$$

where:

$Z_b$  and  $Z_c$  plastic moduli of the beams and the columns, respectively,

$N_{Ed}$  is the axial load of the column in the seismic design situation,

$A_c$  is the area of the column section,

$f_{yb}$  is the yield strength of steel in the beam, defined as in **B.5.1(5)**,

$f_{yd,c}$  is the design yield strength of steel in the column, defined as in **B.6.2.1(3)**.

- v. Determine the thickness of the continuity plates to stiffen the column web at the level of the top and bottom beam flange. This thickness should be at least equal to that of the beam flange.
- vi. Check that the strength and stiffness of the panel zone are sufficient for the panel to remain elastic:

$$\boxed{\text{AC1}} d_{wc} \cdot t_{wc} \cdot \frac{f_{yw,d}}{\sqrt{3}} \geq \frac{\sum Z_b \cdot f_{yb}}{d_b} \cdot \left( \frac{L - d_c}{L - d_c - 2 \cdot b} \right) \cdot \left( \frac{H - d_b}{H} \right) \boxed{\text{AC1}} \quad (\text{B.34})$$

where:

$\boxed{\text{AC1}} d_{wc}$  is the depth of the column web,  $\boxed{\text{AC1}}$

$t_{wc}$  is the thickness of the column web, including the doubler plates, if any,

$f_{yw,d}$  is the design yield strength of the panel zone,

$Z_b$  is the plastic modulus of the beams,

$N_{Ed}$  is the axial load of the column in the seismic design situation,

$A_c$  is the area of the column section,

$f_{yb}$  is the yield strength of steel in the beam, defined as in **B.5.1(5)**, and

$H$  is the frame storey height.

- vii. Compute and detail the welds between the joined parts.

### B.6.2.3.2 Semi-rigid connections

- (1) Semi-rigid and/or partial strength connections, either steel or composite, may be used to achieve large plastic deformations without risk of fracture.
- (2) Full interaction shear studs should be welded onto the beam top flange.
- (3) Semi-rigid connections may be designed by assuming that the shear resistance is provided by the components on the web and the flexural resistance by the beam flanges and the slab reinforcement, if any.

### B.6.2.4 Strengthening strategies

#### B.6.2.4.1 Haunched connections

- (1) Beam-to-column connections may be strengthened by adding haunches either only to the bottom, or to the top and the bottom of the beam flanges, forcing the dissipative zone to the end of the haunch. Adding haunches only to the bottom flange is more convenient, because bottom flanges are generally far more accessible than top ones; moreover, the composite slab, if any, does not have to be removed.
- (2) Triangular T-shaped haunches are the most effective among the different types of haunch details. If only bottom haunches are added, their depth should be about one-quarter of the beam depth. In connections with top and bottom haunches, haunch depth should be about one-third of the beam height.
- (3) Transverse stiffeners at the level of the top and bottom beam flanges should be used to strengthen the column panel zone.
- (4) Transverse stiffeners should also be used at the haunch edges, to stiffen the column web and the beam web.
- (5) The vertical stiffeners for the beam web should be full depth and welded on both sides of the web. Their thickness should be sufficient to resist the vertical component of the haunch flange force at that location, and should be not less than the thickness of the beam flange. The local verifications in EN 1993-1-8: 2004, 6.2.6 should be satisfied.
- (6) Haunches should be welded with complete joint penetration welds to both the column and the beam flanges.
- (7) Bolted shear tabs may be left in place, if they exist. Shear tabs may be used in the retrofitted member, if required either for resistance or for execution purposes.
- (8) A step-by-step design procedure may be applied for haunched connections, as follows.
  - i. Select preliminary haunch dimensions on the basis of the slenderness limitation for the haunch web. The following relationships may be used as a first trial for the haunch length,  $a$ , and for the angle of the haunch flange to the haunch of the member,  $\theta$ :

$$a = 0,55 \cdot d_b \quad (\text{B.35})$$

$$\theta = 30^\circ \quad (\text{B.36})$$

where  $d_b$  is the beam depth. The resulting haunch depth  $b$ , given by:

$$b = a \cdot \tan \theta \quad (\text{B.37})$$

should respect architectural constraints, e.g. ceilings and non structural elements.

- ii. Compute the beam plastic moment at the haunch tip,  $M_{pl,Rd,b}$ , from expression (B.17).
- iii. Compute the beam plastic shear ( $V_{pl,Rd,b}$ ) in accordance with **B.5.3.4(3)**v for the span length  $L'$  between the plastic hinges at the ends of the haunches.
- iv. Verify that the column-to-beam flexural capacity ratio,  $CBMR$ , satisfies the condition:

$$CBMR = \frac{\sum Z_c \cdot \left( f_{yd,c} - \frac{N_{Ed}}{A_c} \right)}{\sum M_c} \geq 1,20 \quad (\text{B.38})$$

where:

- $Z_c$  is the plastic section modulus of the columns,
- $f_{yd,c}$  is the design yield strength of steel in the column, defined as in **B.6.2.1(3)**,
- $N_{Ed}$  is the axial load of the column in the seismic design situation,
- $A_c$  is the area of the column section,
- $M_c$  is the sum of column moments at the top and bottom ends of the enlarged panel zone resulting from the development of the beam moment  $M_{pl,R,b}$  within each beam of the connection:

$$\sum M_c = \left[ 2M_{pl,R,b} + V_{pl,Rd,b} \cdot (L - L') \right] \cdot \left( \frac{H_c - \overline{d}_b}{H_c} \right) \quad (\text{B.39})$$

where:

- $L$  is the distance between the column centerlines,
- $\overline{d}_b$  is the depth of the beam including the haunch, and
- $H_c$  is the storey height of the frame.

- v. Compute the value of the non-dimensional parameter  $\beta$  given by:

$$\beta = \frac{b}{a} \cdot \left( \frac{3 \cdot L' \cdot d + 3 \cdot a \cdot d + 3 \cdot b \cdot L' + 4 \cdot a \cdot b}{3 \cdot d^2 + 6 \cdot b \cdot d + 4 \cdot b^2 + \frac{12 \cdot I_b}{A_b} + \frac{12 \cdot I_b}{A_{hf} \cos^3 \theta}} \right) \quad (\text{B.40})$$

where  $A_{hf}$  is the area of the haunch flange.

vi. Compute the value of the non-dimensional parameter  $\beta_{min}$  as:

$$\beta_{min} = \frac{\frac{(M_{pl,Rd,b} + V_{pl,Rd,b} \cdot a)}{S_x} - 0,80 \cdot f_{uw,d}}{\frac{V_{pl,Rd,b} \cdot a}{S_x} + \frac{V_{pl,Rd,b}}{I_b \cdot \tan \theta} \cdot \left( \frac{d^2}{4} - \frac{I_b}{A_b} \right)} \quad (\text{B.41})$$

where:

$f_{uw,d}$  is the design tensile strength of the welds,

$S_x$  is the beam (major) elastic modulus,

$d$  is the beam depth,

$A_b$  and  $I_b$  are respectively the area and moment of inertia of the beam.

vii. Compare the non-dimensional  $\beta$ -values, as calculated above. If  $\beta \geq \beta_{min}$  the haunch dimensions are sufficient and further local checks should be performed in accordance with viii below. If  $\beta < \beta_{min}$  the haunch flange stiffness should be increased, by either increasing the haunch flange area  $A_{hf}$  or by modifying the haunch geometry.

viii. Perform strength and stability checks for the haunch flange:

$$\text{(strength)} \quad A_{hf} \geq \frac{\beta \cdot V_{pl,Rd,b}}{f_{yhf,d} \cdot \sin \theta} \quad (\text{B.42})$$

$$\text{(stability)} \quad \frac{b_{hf}}{t_{hf}} \leq 10 \cdot \sqrt{\frac{235}{f_{yhf,d}}} \quad (\text{B.43})$$

where:

$f_{yhf,d}$  is the design value of the yield strength of the haunch flange,

$b_{hf}$  and  $t_{hf}$  are the flange outstand and the flange thickness of the haunch, respectively.

ix. Perform strength and stability checks for the haunch web:

$$\text{(strength)} \quad \tau_{hw} = \frac{a \cdot V_{pl,Rd,b}}{2 \cdot (1+v) \cdot I_b} \left[ \frac{L'}{2} - \frac{\beta}{\tan \theta} \left( \frac{d}{2} \right) + \frac{(1-\beta) \cdot a}{3} \right] \leq \frac{f_{yhwd}}{\sqrt{3}} \quad (\text{B.44})$$

$$\text{(stability)} \quad \frac{2 \cdot a \cdot \sin \theta}{t_{hw}} \leq 33 \cdot \sqrt{\frac{235}{f_{yhw,d}}} \quad (\text{B.45})$$

where:

$f_{yhw,d}$  is the design value of the yield strength of the haunch web,

$t_{hw}$  is the web thickness,

$\nu$  is the Poisson ratio of steel.

- x. Check the shear capacity of the beam web in accordance with EN 1993-1-8: 2004, **6.2.6**, for a shear force to be resisted by the beam web given by:

$$V_{pl,Rd,bw} = (1 - \beta) \cdot V_{pl,Rd,b} \quad (\text{B.46})$$

where  $\beta$  is given by expression (B.40).

- xi. Design transverse and beam web stiffeners to resist the concentrated force  $\beta V_{pl,Rd,b} / \tan \theta$ . Web stiffeners should possess sufficient strength to resist, together with the beam web, the concentrated load  $(1 - \beta) V_{pl,Rd,b}$ . Width-to-thickness ratios for stiffeners should be limited to 15, to prevent local buckling.
- xii. Detail welds with complete joint penetration welding to connect stiffeners to the beam flange. Two-sided 8 mm fillet welds are sufficient to connect the stiffeners to the beam web.

#### B.6.2.4.2 Cover plate connections

- (1) Cover plate connections can reduce the stress at the welds of the beam flange and force yielding in the beam to occur at the end of the cover plates.
- (2) Cover plates may be used either only at the bottom beam flange, or at the top and bottom beam flanges.
- (3) Steel cover plates should have rectangular shape and should be placed with the rolling direction parallel to the beam.
- (4) Connections with welded beam webs and relatively thin and short cover plates should be preferred over bolted web and heavy and long plates.
- (5) Long plates should not be used for beams with short spans and high shear forces.
- (6) A step-by-step design procedure may be applied for cover plate connections as follows.
  - i. Select the cover plate dimensions on the basis of the beam size:

$$b_{cp} = b_{bf} \quad (\text{B.47})$$



$$t_{cp} = 1,20 \cdot t_{bf} \quad (\text{B.48})$$

$$l_{cp} = \frac{d_b}{2} \quad (\text{B.49})$$

where:

- $b_{cp}$  is the width of the cover plate,
- $t_{cp}$  is the thickness of the cover plate,
- $b_{cf}$  is the width of the beam flange,
- $t_{cf}$  is the thickness of the beam flange,
- $l_{cp}$  is the length of the cover plate, and
- $d_b$  is the beam depth.

- ii. Compute the beam plastic moment ( $M_{pl,Rd,b}$ ) at the end of the cover plates as in expression (B.7).
- iii. Compute the beam plastic shear,  $V_{pl,Rd,b}$ , in accordance with **B.5.3.4(3)<sub>v</sub>** for the distance,  $L'$ , between the plastic hinges in the beam:

$$L' = L - d_c - 2 \cdot l_{cp} \quad (\text{B.50})$$

- iv. Compute the moment at the column flange,  $M_{cf,Ed}$ :

$$M_{cf,Ed} = M_{pl,Rd,b} + V_{pl,Rd,b} \cdot l_{cp} \quad (\text{B.51})$$

- v. Verify that the area of cover plates,  $A_{cp}$ , satisfies the requirement:

$$\left[ Z_b + A_{cp} \cdot (d_b + t_{cp}) \right] \cdot f_{yd} \geq M_{cf,Ed} \quad (\text{B.52})$$

where  $f_{yd}$  is the design yield strength of the cover plates

- vi. Verify that, the column-to-beam flexural capacity ratio,  $CBMR$ , satisfies the condition:

$$CBMR = \frac{\sum Z_c (f_{yd,c} - f_a)}{\sum Z_b \cdot f_{yb} \cdot \left( \frac{L - d_c}{L - d_c - 2 \cdot l_{cp}} \right)} \geq 1,20 \quad (\text{B.53})$$

where:

- $Z_b$  and  $Z_c$  are the plastic moduli of the beams and the columns, respectively,
- $f_{yb}$  is the yield strength of steel in the beam, defined as in **B.5.1(5)**, and
- $f_{yd,c}$  is the design yield strength of steel in the column, defined as in **B.6.2.1(3)**.

- vii. Determine the thickness of the continuity plates placed at the level of the top and bottom beam flanges to stiffen the column web. This thickness should be not less

than that of the beam flange.

- viii. Check that the strength and the stiffness of the panel zone are sufficient for the panel to remain elastic:

$$d_c \cdot t_{wc} \cdot \frac{f_{yw,d}}{\sqrt{3}} \geq \frac{\sum M_f}{d_b} \cdot \left( \frac{L}{L-d_c} \right) \cdot \left( \frac{H-d_b}{H} \right) \quad (\text{B.54})$$

where:

$d_c$  is the depth of the column web,

$t_{wc}$  is the thickness of the column web, including the doubler plates, if any,

$f_{yw,d}$  is the design value of the yield strength of the panel zone, and

$H$  is the frame storey height.

- ix. Dimension and detail the welds between joined parts, i.e. between the beam and the cover plates, between the column and the cover plates and between the beam and the column. Weld overlays should employ the same electrodes as used in the original welds, or at least electrodes with similar mechanical properties.

### B.6.3 Connections of braces and of seismic links

- (1) The connections of braces and of seismic link should be designed taking into account the effects of cyclic post-buckling behaviour.
- (2) Rigid connections should be preferred to nominally pinned ones (see EN 1998-1-8: 2004, 5.2.2).
- (3) To improve out-of-plane stability of the bracing connection, the continuity of beams and columns should not be interrupted.
- (4) The brace and the beam centrelines should not intersect outside the seismic link.
- (5) In connections of diagonal braces and beams, the centrelines of these members should intersect either within the length of the link or at its end.
- (6) For connection of a seismic link to a column at column flange face, bearing end plates should be used between the beam flange plates.
- (7) Retrofitting of beam-to-column connections may change the length of the seismic link. Therefore, the link should be checked after the repair strategy is adopted.
- (8) Seismic links connected to the column should be short.
- (9) Welded connections of a seismic link to the column weak-axis should be avoided.

## ANNEX C (Informative)

### MASONRY BUILDINGS

#### C.1 Scope

- (1) This annex contains recommendations for the assessment and the design of the retrofitting of masonry buildings in seismic regions.
- (2) The recommendations of this section are applicable to concrete or brick masonry lateral force resisting elements, within a building system in un-reinforced, confined or reinforced masonry.

#### C.2 Identification of geometry, details and materials

##### C.2.1 General

- (1) The following aspects should be carefully examined:
  - i. Type of masonry unit (e.g., clay, concrete, hollow, solid, etc.).
  - ii. Physical condition of masonry elements and presence of any degradation.
  - iii. Configuration of masonry elements and their connections, as well as the continuity of load paths between lateral resisting elements.
  - iv. Properties of constituent materials of masonry elements and quality of connections.
  - v. The presence and attachment of veneers, the presence of nonstructural components, the distance between partition walls.
  - vi. Information on adjacent buildings potentially interacting with the building under consideration.

##### C.2.2 Geometry

- (1) The collected data should include the following items
  - i. Size and location of all shear walls, including height, length and thickness.
  - ii. Dimensions of masonry units.
  - iii. Location and size of wall openings (doors, windows).
  - iv. Distribution of gravity loads on bearing walls.

### **C.2.3 Details**

- (1) The collected data should include the following items
- i. Classification of the walls as un-reinforced, confined, or reinforced.
  - ii. Presence and quality of mortar.
  - iii. For reinforced masonry walls, amount of horizontal and vertical reinforcement.
  - iv. For multi-leaf masonry (rubble core masonry walls), identification of the number of leaves, respective distances, and location of ties, when existing.
  - v. For grouted masonry, evaluation of the type, quality and location of grout placements.
  - vi. Determination of the type and condition of the mortar and mortar joints; Examination of the resistance, erosion and hardness of the mortar; Identification of defects such as cracks, internal voids, weak components and deterioration of mortar.
  - vii. Identification of the type and condition of connections between orthogonal walls.
  - viii. Identification of the type and condition of connections between walls and floors or roofs.
  - ix. Identification and location of horizontal cracks in bed joints, vertical cracks in head joints and masonry units, and diagonal cracks near openings.

Examination of deviations in verticality of walls and separation of exterior leaves or other elements as parapets and chimneys.

### **C.2.4 Materials**

- (1) Non-destructive testing may be used to quantify and confirm the uniformity of construction quality and the presence and degree of deterioration. The following types of tests may be used:
- i. Ultrasonic or mechanical pulse velocity to detect variations in the density and modulus of masonry materials and to detect the presence of cracks and discontinuities.
  - ii. Impact echo test to confirm whether reinforced walls are grouted.
  - iii. Radiography and cover meters, where appropriate, to confirm location of reinforcing steel.
- (2) Supplementary tests may be performed to enhance the level of confidence in masonry material properties, or to assess masonry condition. Possible tests are:
- i. Schmidt rebound hammer test to evaluate surface hardness of exterior masonry walls.

- ii. Hydraulic flat jack test to measure the in-situ shear strength of masonry. This test may be in conjunction with flat jacks applying a measured vertical load to the masonry units under test.
- iii. Hydraulic flat jack test to measure the *in-situ* vertical compressive stress resisted by masonry. This test provides information such as the gravity load distribution, flexural stresses in walls, and stresses in masonry veneer walls compressed by surrounding concrete frame.
- iv. Diagonal compression test to estimate shear strength and shear modulus of masonry.
- v. Large-scale destructive tests on particular regions or elements, to increase the confidence level on overall structural properties or to provide particular information such as out-of-plane strength, behaviour of connections and openings, in-plane strength and deformation capacity.

### **C.3 Methods of analysis**

#### **C.3.1 General**

- (1) In setting up the model for the analysis, the stiffness of the walls should be evaluated taking into account both flexural and shear flexibility, using cracked stiffness. In the absence of more accurate evaluations, both contributions to stiffness may be taken as one-half of their respective uncracked values.
- (2) Masonry spandrels may be introduced in the model as coupling beams between two wall elements.

#### **C.3.2 Linear methods: Static and Multi-modal**

- (1) These methods are applicable under the following conditions, which are additional to the general conditions of **4.4.2(1)P**
  - i. The lateral load resisting walls are regularly arranged in both horizontal directions.
  - ii. Walls are continuous along their height.
  - iii. The floors possess enough in-plane stiffness and are sufficiently connected to the perimeter walls to assume that they can distribute the inertia forces among the vertical elements as a rigid diaphragm.
  - iv. Floors on opposite sides of a common wall are at the same height.
  - v. At each floor, the ratio between the lateral in-plane stiffnesses of the stiffest wall and the weakest primary seismic wall, evaluated accounting for the presence of openings, does not exceed 2,5.
  - vi. Spandrel elements included in the model are either made of blocks adequately interlocked to those of the adjacent walls, or have connecting ties.

### C.3.3 Nonlinear methods: Static and dynamic

- (1) These methods should be applied when the conditions in **C.3.2** are not met.
- (2) Capacity is defined in terms of roof displacement. The ultimate displacement capacity is taken as the roof displacement at which total lateral resistance (base shear) has dropped below 80% of the peak resistance of the structure, due to progressive damage and failure of lateral load resisting elements.
- (3) The demand, to be compared to the capacity, is the roof displacement corresponding to the target displacement of **4.4.4.4** and EN 1998-1: 2004, **4.3.3.4.2.6(1)** for the seismic action considered.

NOTE Informative Annex B of EN 1998-1: 2004 gives a procedure for the determination of the target displacement from the elastic response spectrum.

## C.4 Capacity models for assessment

### C.4.1 Models for global assessment

#### C.4.1.1 LS of Near Collapse (NC)

- (1) Assessment criteria given in terms of global response measures can be applied only when the analysis is nonlinear.
- (2) Global capacity at the LS of Near Collapse (NC) may be taken equal to the ultimate displacement capacity defined in **C.3.3(2)**.

#### C.4.1.2 LS of Significant Damage (SD)

- (1) **C.4.1.1(1)** applies.
- (2) Global capacity at the LS of Significant Damage (SD) may be taken equal to 3/4 of the ultimate displacement capacity defined in **C.3.3(2)**.

#### C.4.1.3 LS of Damage Limitation (DL)

- (1) If a linear analysis is performed, the criterion for global assessment is defined in terms of the base shear in the horizontal direction of the seismic action. The capacity may be taken equal to the sum of shear force capacities of the individual walls, as this is controlled by flexure (see **C.4.2.1(1)**) or by shear (see **C.4.3.1(1)**) in the horizontal direction of the seismic action. The demand is the estimate of the maximum base shear in that direction from the linear analysis.
- (2) If nonlinear analysis is performed, the capacity for global assessment is defined as the yield point (yield force and yield displacement) of the idealized elasto-perfectly plastic force – displacement relationship of the equivalent Single-Degree-of-Freedom system.

NOTE Informative Annex B of EN 1998-1: 2004 gives a procedure for the determination of the yield force and the yield displacement of the idealized elasto-perfectly plastic force –

displacement relationship of the equivalent Single-Degree-of-Freedom system.

## C.4.2 Elements under normal force and bending

### C.4.2.1 LS of Significant Damage (SD)

(1) The capacity of an unreinforced masonry wall is controlled by flexure, if the value of its shear force capacity given in C.4.2.1(3) is less than the value given in C.4.3.1(3).

(2) The capacity of an unreinforced masonry wall controlled by flexure may be expressed in terms of drift and taken equal to  $0,008 \cdot H_0/D$  for primary seismic walls and to  $0,012 \cdot H_0/D$  for secondary ones, where:

$D$  is the in-plane horizontal dimension of the wall (depth),

$H_0$  is the distance between the section where the flexural capacity is attained and the contraflexure point.

(3) The shear force capacity of an  $\langle AC_1 \rangle$  unreinforced masonry wall controlled by  $\langle AC_1 \rangle$  flexure under an axial load  $N$ , may be taken equal to:

$$V_f = \frac{DN}{2H_0} (1 - 1,15 v_d) \quad (C.1)$$

where

$D$  and  $H_0$  are as defined in (2),

$v_d = N/(Dt f_d)$  is the normalized axial load (with  $f_d = f_m/CF_m$ , where  $f_m$  is the mean compressive strength as obtained from in-situ tests and from the additional sources of information, and  $CF_m$  is the confidence factor for masonry given in Table 3.1 for  $\langle AC_1 \rangle$  the appropriate knowledge level  $m$ ),  $t$  is the wall  $\langle AC_1 \rangle$  thickness.

### C.4.2.2 LS of Near Collapse (NC)

(1) C.4.2.1(1) and C.4.2.1(3) apply.

(2) The capacity of a masonry wall controlled by flexure may be expressed in terms of drift and taken equal to 4/3 of the values in C.4.2.1(2).

### C.4.2.3 LS of Damage Limitation (DL)

(1) C.4.2.1(1) applies.

(2) The capacity of an unreinforced masonry wall controlled by flexure may be taken as the shear force capacity given in C.4.2.1(3).

### C.4.3 Elements under shear force

#### C.4.3.1 LS of Significant Damage (SD)

(1) The capacity of an unreinforced masonry wall is controlled by shear, if the value of its shear force capacity given in **C.4.3.1(3)** is less than or equal to the value given in **C.4.2.1(3)**.

(2) The capacity of an unreinforced masonry wall controlled by shear may be expressed in terms of drift and taken equal to 0,004 for primary seismic walls and to 0,006 for secondary ones.

(3) The shear force capacity of an unreinforced masonry wall controlled by shear under an axial load  $N$ , may be taken equal to:

$$V_f = f_{vd} D' t \quad (\text{C.2})$$

where:

$D'$  is the depth of the compressed area of the wall,

$t$  is the wall thickness, and

$f_{vd}$  is the masonry shear strength accounting for the presence of vertical load:  $= f_{vm0} + 0,4 N/D' t \leq 0,065 f_m$ , where  $f_{vm0}$  is the mean shear strength in the absence of vertical load and  $f_m$  the mean compressive strength, both as obtained from in-situ tests and from the additional sources of information, and divided by the confidence factors, as defined in the **3.5(1)P** and Table 3.1, accounting for the level of knowledge attained. In primary seismic walls, both these material strengths are further divided by the partial factor for masonry in accordance with EN1998-1: 2004, **9.6**.

#### C.4.3.2 LS of Near Collapse (NC)

(1) **C.4.3.1(1)** and **C.4.3.1(3)** apply.

(2) The capacity of an unreinforced masonry wall controlled by shear may be expressed in terms of drift and taken as 4/3 of the values in **C.4.3.1(2)**.

#### C.4.3.3 LS of Damage Limitation (DL)

(1) **C.4.3.1(1)** applies.

(2) The capacity of an unreinforced masonry wall controlled by shear may be taken as the shear force capacity given in **C.4.3.1(3)**.



## C.5 Structural interventions

### C.5.1 Repair and strengthening techniques

#### C.5.1.1 Repair of cracks

- (1) If the crack width is relatively small (e.g., less than 10 mm) and the thickness of the wall is relatively small, cracks may be sealed with mortar.
- (2) If the width of cracks is small but the thickness of the masonry is not, cement grout injections should be used. Where possible, no-shrinkage grout should be used. Epoxy grouting may be used instead, for fine cracks.
- (3) If the crack are relatively wide (e.g., more than 10 mm), the damaged area should be reconstructed using elongated (stitching) bricks or stones. Otherwise, dovetailed clamps, metal plates or polymer grids should be used to tie together the two faces of the crack. Voids should be filled with cement mortar of appropriate fluidity.
- (4) Where bed-joints are reasonably level, the resistance of walls against vertical cracking can be considerably improved by embedding in bed-joints either small diameter stranded wire ropes or polymeric grid strips.
- (5) For repair of large diagonal cracks, vertical concrete ribs may be cast into irregular chases made in the masonry wall, normally on both sides. Such ribs should be reinforced with closed stirrups and longitudinal bars. Stranded wire rope as in (4) should run across the concrete ribs. Alternatively, polymeric grids may be used to envelop one or both faces of the masonry walls, combined with appropriate mortar and plaster.

#### C.5.1.2 Repair and strengthening of wall intersections

- (1) To improve connection between intersecting walls, use should be made of cross-bonded bricks or stones. The connection may be made more effective in different ways:
  - i. Through construction of a reinforced concrete belt,
  - ii. By addition of steel plates or meshes in the bed-joints,
  - iii. Through insertion of inclined steel bars in holes drilled in the masonry and grouting thereafter,
  - iv. Through post-tensioning.

#### C.5.1.3 Strengthening and stiffening of horizontal diaphragms

- (1) Timber floors may be strengthened and stiffened against in-plane distortion by:
  - i. nailing an additional (orthogonal or oblique) layer of timber boards onto the existing ones,
  - ii. casting an overlay of concrete reinforced with welded wire mesh. The concrete

overlay should have shear connection with the timber floor and should be anchored to the walls,

iii. placing a doubly-diagonal mesh of flat steel ties anchored to the beams and to the perimeter walls.

(2) Roof trusses should be braced and anchored to the supporting walls. A horizontal diaphragm should be created (e.g. by adding bracing) at the level of the bottom chords of the trusses.

#### **C.5.1.4 Tie beams**

(1) If existing tie-beams between walls and floors are damaged, they should be repaired or rebuilt. If there are no tie-beams in the original building structure, such beams should be added.

#### **C.5.1.5 Strengthening of buildings by means of steel ties**

(1) The addition of steel ties, along or transversely to the walls, external or within holes drilled in the walls, is an efficient means of connecting walls and improving the overall behaviour of masonry buildings.

(2) Posttensioned ties may be used to improve the resistance of the walls against tensile stresses.

#### **C.5.1.6 Strengthening of rubble core masonry walls (multi-leaf walls)**

(1) The rubble core may be strengthened by cement grouting, if the penetration of the grout is satisfactory. If adhesion of the grout to the rubble is likely to be poor, grouting should be supplemented by steel bars inserted across the core and anchored to the outer leafs of the wall.

#### **C.5.1.7 Strengthening of walls by means of reinforced concrete jackets or steel profiles**

(1) The concrete should be applied by the shotcrete method and the jackets should be reinforced by welded wire mesh or steel bars.

(2) The jackets may be applied on only one face of the wall, or preferably on both. The two layers of the jacket applied to opposite faces of the wall, should be connected by means of transverse ties through the masonry. Jackets applied on only one face, should be connected to the masonry by chases.

(3) Steel profiles may be used in a similar way, provided they are appropriately connected to both faces of the wall or on one face only.

#### **C.5.1.8 Strengthening of walls by means of polymer grids jackets**

(1) Polymer grids may be used to strengthen existing and new masonry elements. In case of existing elements, the grids should be connected to masonry walls from one sides or both sides and should be anchored to the perpendicular walls. In case of new

elements, the intervention may involve the additional insertion of grids in the horizontal layers of mortar between bricks. Plaster covering polymeric grids should be ductile, preferably lime-cement with fibre reinforcement.